

building - furniture

THE BEST OF **Fine**
Wood Working

How to make:

Bookcases • Tables • Chairs
Cabinets • Chests • Bureaus
Beds • Sideboards



\$8.99/Canada \$9.99

A Taunton Publication



www.finewoodworking.com

LEFT-TILT BLADE

45°

CAST IRON WINGS AND TABLE WITH T-SLOTS

BIESEMEYER COMMERCIAL
FENCE SYSTEM

INDUSTRIAL TRUNNION SYSTEM
WITH UPFRONT CONTROLS

HEAVY DUTY STAND WITH
VIBRATION-REDUCING FEET

HEAVY DUTY INDUSTRIAL
1-1/2 HP INDUCTION MOTOR

INTEGRATED
MOBILE BASE



THE LEFT-TILT CONTRACTOR'S SAW. PERFECTED.

It should come as no surprise that DELTA® took the time to introduce left-tilt Contractor's Saws® the right way. After all, DELTA invented the Contractor's Saw category. And once you try a DELTA, there's no going back. Besides a left-tilt blade and powerful 1-1/2 HP motor, you also have a choice of three fence systems including a Biesemeyer® or DELTA® UNIFENCE®. You even get maximum mobility with a newly designed base. Plus, its new collection tray captures 80 - 90% of the dust. So find perfection. Visit deltamachinery.com/contractor for more details, or to join our DELTA Owners Group.

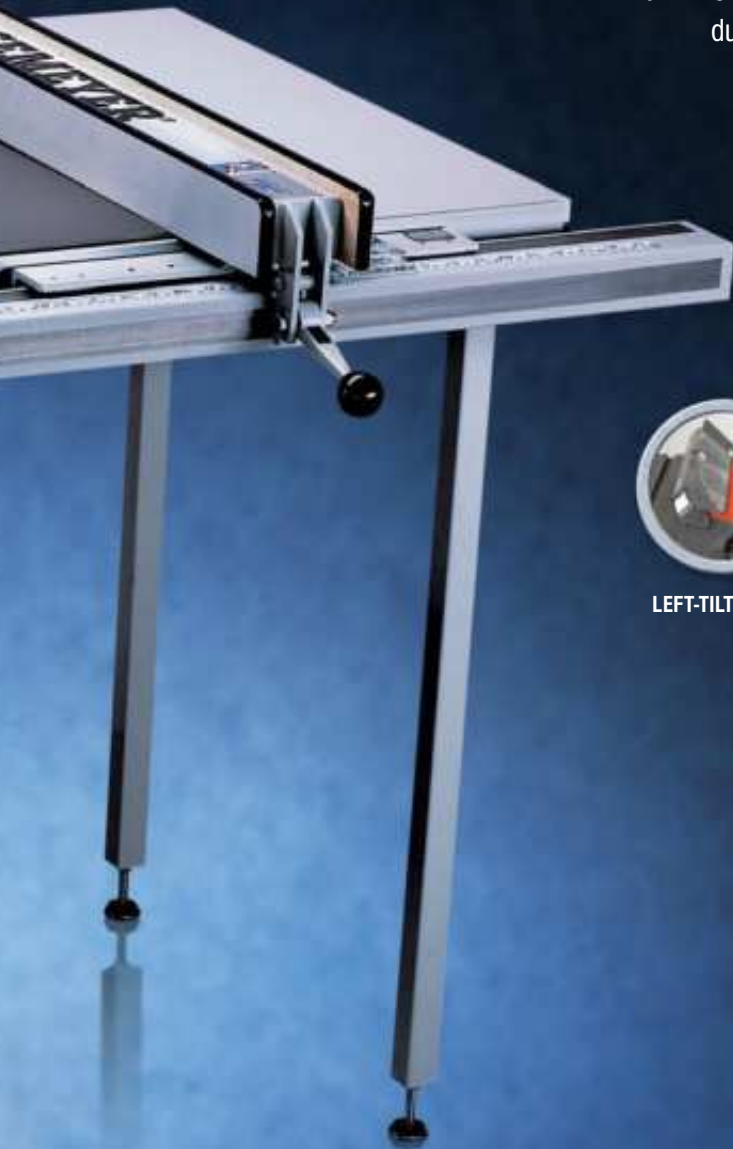

LEFT-TILT BLADE



INTEGRATED
MOBILE BASE



DUST PORT



 **DELTA®**
YOUR ACHIEVEMENT. OUR TOOLS.

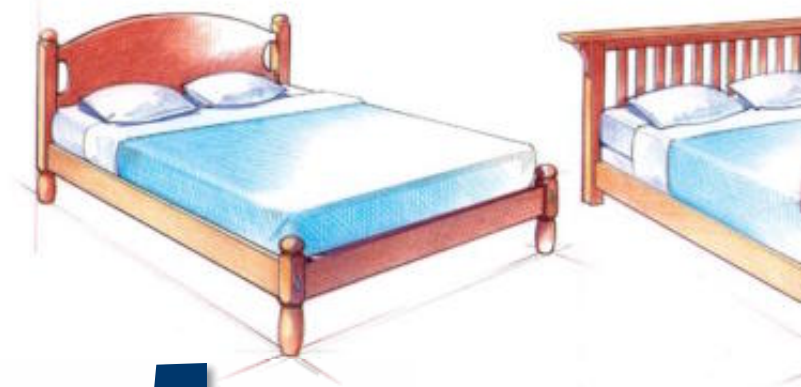

contents

Bookshelves

- 18** Three Bookcases
From simple to elegant, three approaches to building a home for your books
BY PHILIP C. LOWE

- 24** Sturdy Shelves
How to build shelves that won't wilt under load
BY JEFF MILLER



Tables

- 30** Table Design
A well-proportioned table offers both comfort and style
BY GRAHAM BLACKBURN

- 34** Strong Joints
Build sturdier tables by beefing up the basic mortise and tenon
BY GARRETT HACK

- 38** Attaching Tabletops
Four ways to secure a top to its base
BY MARIO RODRIGUEZ

- 42** Tables With Drawers
Build tables with one or more drawers to last for generations
BY WILL NEPTUNE

78 DESIGNING DRAWERS

Beds

- 48** Anatomy of a Bed
Construction details that work with almost any design
BY JEFF MILLER

Chairs

- 54** Chairmaking Basics
The right approach combines efficiency, comfort, strength, and beauty
BY KEVIN RODEL

Cabinets

- 62** Chest of Drawers
Build a strong case and then change details to suit the style
BY WILL NEPTUNE

- 70** Classic Sideboard
Common-sense approach to joinery in complex cabinets
BY WILL NEPTUNE

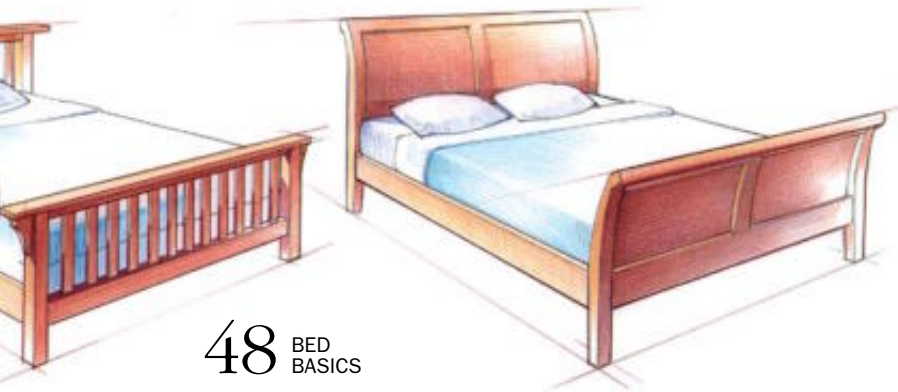

48 BED
BASICS



62 CHEST OF
DRAWERS

Drawers

78 Illustrated Guide to Drawers

From simple to refined, drawer options for the furniture maker

BY MATTHEW TEAGUE

82 Dovetailed Drawer

Learn to build traditional drawers that stand the test of time

BY JANET A. COLLINS

88 Side-Hung Drawer Slides

No-nonsense approach keeps drawers running straight and smooth

BY MARK EDMUNDSON

Doors

94 Doors for Furniture

An illustrated guide to door construction

BY GRAHAM BLACKBURN

99 Handmade Catches and Latches

Four elegant ways to keep doors in place

BY ANDY RAE, CHRISTIAN BECKSVOORT, DOUG NOYES, AND MICHAEL PEKOVICH

104 Installing Butt Hinges

Traditional hinge will look and work great for decades

BY GARRETT HACK

Departments

6 Editor's Letter

8 Quick Tips

- Jig makes it easier to cut keys in miters
- Hold a drawer securely for planing
- Improved tabletop button

14 Getting Started

Managing moisture

112 Q&A

- Basics of breadboard-end construction
- How to size and space dovetails
- Securing a wide table apron



24 STURDY
SHELVES

 The Taunton Press
Inspiration for hands-on living®

FineWoodworking.com

editor's letter

DISCOVER THE JOY OF FURNITURE MAKING

When I started at *Fine Woodworking* magazine 10 years ago, I had well-honed editing skills but only basic woodworking knowledge. Back then, I was making very simple projects, things I needed to keep my house organized, such as basic bookcases, tables, and shelves. But after reading and editing hundreds of articles on furniture design and construction, I know how to build furniture that's sound both structurally and aesthetically, and I have the confidence to tackle more complex pieces. I'd like to pass along what I've learned at *Fine Woodworking* in one inclusive magazine: *Building Furniture*. This special collection of *Fine Woodworking's* best articles on furniture construction and anatomy comes from some of the country's foremost woodworking experts. Lessons learned here can be applied to a broad range of furniture types and styles from various periods. You'll learn how to build bookcases, tables, chairs, cabinets, chests of drawers, and beds in dozens of styles. You'll also get in-depth information on building doors and drawers. If you want to build stylish furniture that will last generations, dive in, explore, and enjoy the journey.



—Tom McKenna
Building Furniture editor

FineWoodworking.com/BuildingFurniture

For more inspiration and advice on handmade furniture, visit our Web site to explore photos, video tutorials, and audio slide shows. Also, browse more than 1,500 images of custom furniture submitted by readers around the world.

VIDEOS:

- Furniture maker Matthew Teague goes step-by-step through the process of making a drawbored mortise and tenon.
- Graham Blackburn shares practical tips and design inspiration for designing frame-and-panel furniture parts.
- *Fine Woodworking* contributing editor Gary Rogowski shares his favorite technique for laying out dovetails with a ruler and simple math.



Fine
Woodworking®

Building Furniture

ISSUE EDITOR

Thomas McKenna

ISSUE ART DIRECTOR

Michael Pekovich

CONTRIBUTING COPY EDITOR

Katy Zirwes Scott

CONTRIBUTING DESIGNER

Susan Lampe-Wilson

Fine Woodworking magazine

EDITOR **Asa Christiana**

ART DIRECTOR **Michael Pekovich**

MANAGING EDITOR **Mark Schofield**

MANAGING EDITOR, ONLINE **Matt Berger**

ASSOCIATE EDITORS

Tom Begnal, Steve Scott, Thomas McKenna, David Heim, Charlie Reina

ASSISTANT EDITOR **Anissa Kapsales**

ASSISTANT EDITOR, ONLINE **Gina Eide**

SENIOR COPY/PRODUCTION EDITORS

Elizabeth Healy, Julie Risinit

ASSOCIATE ART DIRECTOR **Kelly J. Dunton**

ASSISTANT ART DIRECTOR **John Tetreault**

SHOP MANAGER **John White**

ADMINISTRATIVE ASSISTANT **Betsy Engel**

CONTRIBUTING EDITORS

Christian Becksvoot, Gary Rogowski, Garrett Hack, Roland Johnson, Steve Latta

METHODS OF WORK **Jim Richey**

PUBLISHER

Anatole Burkin

MARKETING MANAGER **Melissa Robinson**

ADMINISTRATIVE ASSISTANT **Christina Glennon**

CIRCULATION DIRECTOR **Dennis O'Brien**

SENIOR SINGLE COPY SALES MANAGER **Jay Annis**

ADVERTISING SALES MANAGER

Peter Badeau

SENIOR NATIONAL ACCOUNT MANAGER

Linda Abbott

NATIONAL ACCOUNT MANAGER **John Lagan**

CORPORATE ACCOUNTS MANAGER **Judy Caruso**

SENIOR AD SALES SUPPORT ASSOCIATE

Marjorie Brown

WOODWORKING BOOKS & VIDEOS

EXECUTIVE EDITOR **Helen Albert**

Building Furniture: (ISSN: 1936-8127) is published by The Taunton Press, Inc., Newtown, CT 06470-5506. Telephone 203-426-8171. Canadian GST paid registration #123210981.

Printed in the USA

HOW TO CONTACT US:

Fine Woodworking

The Taunton Press, 63 S. Main St., PO Box 5506,
Newtown, CT 06470-5506 203-426-8171

www.finewoodworking.com

Editorial:

To contribute an article, give a tip, or ask a question, contact *Fine Woodworking* at the address above or:

Call: **800-309-8955**

Fax: **203-270-6753**

Email: fw@taunton.com

Customer Service:

For subscription inquiries, you can:

- Visit our subscriber service section at:

www.finewoodworking.com

- Email us: fwservice@taunton.com

- Call our customer support center:

To report an address change, inquire about an order, or solve a problem, call:

800-477-8727

To subscribe, purchase back issues, books or videos, or give a gift, call:

800-888-8286

Advertising:

To find out about advertising:

Call: **800-309-8954**

Email: fwads@taunton.com

Retail:

If you'd like to carry *Fine Woodworking* in your store, call the Taunton Trade Company at:

866-505-4674

The Taunton Guarantee:

If at any time you're not completely satisfied with *Fine Woodworking*, you can cancel your subscription and receive a full and immediate refund of the entire subscription price. No questions asked.

Copyright 2007 by The Taunton Press, Inc. No reproduction without permission of The Taunton Press, Inc.

FWE 0713

Fine Woodworking's Tool Test - May/June 2007



#171-2605

**AUTHOR'S
BEST OVERALL
CHOICE**

- Eagle America - Voted Best Overall Router Bit
- Over 800 American-Made Router Bits and Sets Plus Thousands of Woodworking Accessories
- Request your FREE Catalog Today!

Quality Woodworking Products... EXCEPTIONAL SERVICE



**EAGLE
AMERICA**

1-800-872-2511
www.EagleAmerica.com

The Best Wood Glue Ever

What makes Titebond® III Ultimate Wood Glue the best ever? It's waterproof, yet cleans up with water. It allows eight minutes of open assembly time and offers an application temperature as low as 47° F.



Plus it's vastly stronger, safer, easier to clean up and less expensive than polyurethane glues.

Titebond® III. We see it as a natural progression of tradition and excellence. You'll see it as the ultimate wood glue.

1-800-347-4583
www.titebond.com





The Taunton Press
Inspiration for hands-on living®

INDEPENDENT PUBLISHERS SINCE 1975

TAUNTON, INC.

Founders, Paul and Jan Roman

THE TAUNTON PRESS

President Suzanne Roman

Executive Vice President &
Chief Financial Officer Timothy Rahr

Executive Vice President &
Publisher, Magazine Group Jon Miller

Chief of Operations Thomas Luxeder

DIRECTORS

Creative & Editorial Director Susan Edelman

Human Resources Director Carol Marotti

Technology Services Director Jay Hartley

Controller Wayne Reynolds

Advertising Director David Gray

Fulfillment Director Patricia Williamson

Financial Analysis Director Kathy Worth

Circulation Director Dennis O'Brien

THE TAUNTON PRESS

Books: *Marketing:* Melissa A. Possick, Audrey Locorotondo. *Publicity:* Nicole Salvatore, Janel Noblin. *Editorial:* Helen Albert, Kathryn Benoit, Peter Chapman, Steve Culpepper, Pamela Hoenig, Courtney Jordan, Carolyn Mandarano, Nicole Palmer, Jennifer Russell, Erica Sanders-Foeg, Kathleen Williams. *Art:* Alison Wilkes, Nancy Boudreau, Amy Griffin, Sandra Mahlstedt, Wendi Mijal, Lynne Phillips, Carol Singer. *Manufacturing:* Thomas Greco, Laura Burrone.

Business Office: Holly Smith, Gayle Hammond, Patricia Marini. *Legal:* Carolyn Kovalski. *Magazine Print Production:* Philip Van Kirk, Nicole Anastas, Jennifer Kaczmarcyk.

Circulation: David Pond, Andrew Corson, Catherine Hansen.

Distribution: Paul Seipold, Walter Aponte, Frank Busino, David DeToto, Leanne Furlong, Deborah Greene, Frank Melbourne, Reinaldo Moreno, Raymond Passaro, Alice Saxton.

Finance/Accounting: *Finance:* Brett Manning. *Accounting:* Patrick Lamontagne, Lydia Krikorian, Judith O'Toole, Elaine Yamin, Carol Diehm, Dorothy Blasko, Susan Burke, Lorraine Parsons, Larry Rice, James Tweedle, Priscilla Jennings.

Fulfillment: Diane Goulart. *Fulfillment Systems:* Jodi Klein, Kim Eads, Nancy Knorr, Thomas Kuzebski. *Customer Service:* Kathleen Baker, Bonnie Beardsley, Deborah Ciccio, Katherine Clarke, Alfred Dreher, Paula Ferreri, Eileen McNulty, Patricia Parks, Deana Parker, Patricia Pineau, Betty Stepney. *Data Entry:* Melissa Youngberg, Anne Champlin, Mary Ann Colbert, Caryne-Lynne Davis, Maureen Pekar, Debra Sennefelder, Andrea Shorrock, Marylou Thompson, Barbara Williams.

Human Resources: Linda Ballerini, Christine Lincoln, Dawn Ussery.

Sled for cutting key-miter slots

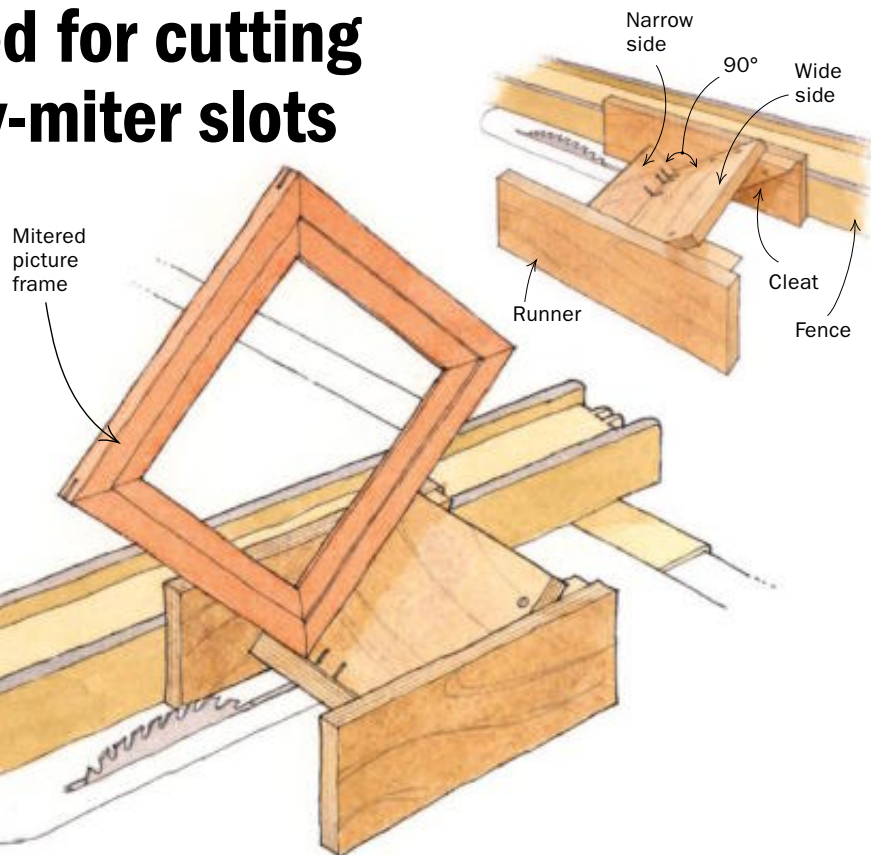

Adding solid-wood keys to mitered picture frames or mitered boxes not only makes the joint stronger, but it also adds interest. Typically, I use only one key per joint when making a picture frame. When making a box, I'll add several keys to each joint.

A key miter is made in three steps. First, the frame or box is glued up. Then a slot is cut in the miter joint. After that, the key is made and glued into the slot. Once the glue dries, the key is trimmed flush.

No matter how many key miters I add to a joint, the sled shown here always makes it easier to cut the slots. In use, it slides front to back while bearing against the fence of a tablesaw or router table. The location of the slot is set by moving the fence toward or away from the blade or router bit.

The sled is made of plywood or medium-density fiberboard (MDF). It consists of a V-shaped trough made up of two sides—one wide, one narrow—that meet at 90°. The ends of the trough extend to runners, where a pair of cleats, some wood glue, and a few wood screws join everything together. When connected to the runners, the sides of the trough intersect the saw or router table at 45°.

To cut a slot, the work is nestled into the trough and butted against the inside runner. As a result, I can hold the frame (or box) securely in place (keeping my fingers away from the path of the sawblade) as the work is passed over the blade or bit.

—GARY ROGOWSKI, contributing editor to *Fine Woodworking*

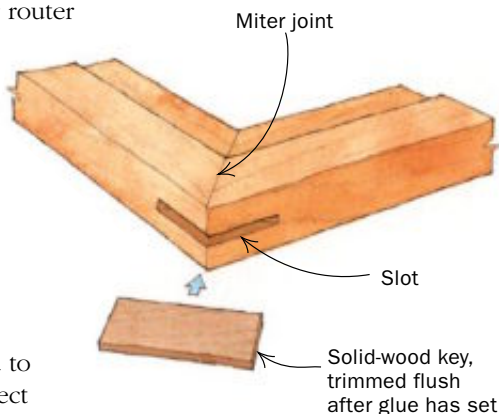

Information Technology Services: Applications

Development: Heidi Waldkirch, Jun Lu, Frank Miller, Robert Nielsen, Linda Reddington, John Vaccino, Daniel Woodhouse. *Desktop and Network Support:* Kenneth Jones, Petre Cotofana, Paul DelPadre, Gabriel Dunn, Michael Lewis, Jay Ligouri.

Operations: Joseph Morits, Roberta Calabrese, Kevin DeGroate, Leah Flynn, John Gedney, Marc Imbimbo, Jennifer Licursi, Susan Nerich, Jeannette Pascal, Amy Reilly. *T Room:* Michael Louchen, Geraldine Benno, Anna Pendergast, Anne Scheurer, Norma-Jean Taylor. *Maintenance:* Lincoln Peters.

Promotion: Jane Weber, *Promotion Creative:* Jennifer Wheeler Conlon, Kristen Coons, Michele Mayernik, Sandra Motyka, Nicole Pallatto, William Sims. *Promotion Operations:* Diane Flanagan, John Cavallaro, Sandra Hannan, Kate Krentsa.

Taunton Creative: Michael Amaditz, Sarah Opdahl. *Video:* Gary Junken.

Publishing Services: Deborah Cooper. *Publishing Technologies:* Mark Merritt, Tracy Goodpaster. *Photography:* Scott Phillips. *Prepress:* Richard Booth, William Bivona, David Blasko, Richard Correale, William Godfrey, Brian Leavitt, Chansam Thammavongsa. *Advertising Production:* Laura Bergeron, Lisa DeFeo, Steven Molnar, Patricia Petro, Kathryn Simonds, Martha Stammer.

TAUNTON DIRECT

Donna Capalbo, Keri DeGross, Michele Ladyko, Kathleen McGreevy, Michael Valanzola.

TAUNTON INTERACTIVE

Jodie Delohery, Robert Harlow, David Hall, Christopher Casey, Mark Coleman, Trish Dardine, Ruth Dobseavage, Lisa Durand, Erika Foreman, Geoff Krajewski, Steve Lombardi, Victoria North, Michael Stoltz, Dawn Viglione.

TAUNTON TRADE

Kevin Hamric, Director; John Bacigalupi, Brett DeMello, Allison Hollett, Elizabeth Quintiliano, Rebecca Shafton. *Single Copy Sales:* Jay Annis, Mark Stiekman, Valerie Droukas.

TAUNTON MAGAZINES

*Fine Woodworking • Fine Homebuilding
Threads • Fine Gardening • Fine Cooking*

Our magazines are for people who are passionate about their pursuits. Written by practicing experts in the field, Taunton Press magazines provide authentic, reliable information supported by instructive and inspiring visuals.

TAUNTON BOOKS

Our books are filled with in-depth information and creative ideas from the finest authors in their fields. Whether you're practicing a craft or engaged in the creation of your home, Taunton books will inspire you to discover new levels of accomplishment.

WWW.TAUNTON.COM

Our website is a place where you can discover more about the interests you enjoy, converse with fellow enthusiasts, shop at our convenient on-line store or contact customer service.

EMPLOYMENT INFORMATION

To inquire about career opportunities, please visit our website at careers.taunton.com. You may also write to The Taunton Press, Human Resources, 63 S. Main St., Box 5506, Newtown, CT 06470.

CUSTOMER SERVICE

We are here to answer any questions you might have and to help you order our magazines, books and videos. Just call us toll-free at 800-477-8727.

The Taunton Press, Inc., Taunton Direct, Inc., Taunton Trade, Inc., and Taunton Interactive, Inc., are all subsidiaries of Taunton, Inc.

CENTER for FURNITURE CRAFTSMANSHIP

Teaching Creative Excellence

WORKSHOPS
STUDIO FELLOWSHIPS
TWELVE-WEEK INTENSIVES
NINE-MONTH COMPREHENSIVE

Rockport, Maine
www.woodschooll.org



Blum Smooth Plane



BlumToolCo.
UNIQUE DESIGNS FOR QUALITY TOOLS
406 Pearl Street, Walnut, IA 51577
Unique Planes, Sharpening Jigs & Portable Workbench
1-800-521-5458
www.blumtoolco.com

SHAKER

A fine collection of reproduction Shaker furniture, oval boxes and more. Available as do-it-yourself kits or custom finished. Large selection of replacement chair tapes.



Call now for free catalog
1-800-840-9121
SHAKER WORKSHOPS
Box 8001-FW
Ashburnham, MA 01430
www.shakerworkshops.com/fw

WOOD MOISTURE METER

New mini-Ligno E/D
High Performance
Low-cost

For hobbyists and woodworkers to avoid frustrating moisture problems.



Call for new Brochure

Lignomat USA
800-227-2105
PO 30145, Portland OR 97294
503-257-8957, FAX 503-255-1430, www.lignomat.com, sales@lignomat.com

Using Quality Hardware

Good hardware means different things to different people. No matter the style, there are three elements to consider:

Material: You chose your wood carefully. Choose the hardware just as carefully. We use solid brass. It lasts forever.

Construction: Good construction is a must. Hardware reflects the countless hours spent building your masterpiece. Details make the difference.

Finish: You've strived to get your wood to glow. The brasses need to accentuate that effort. A beautiful finish is the final step.



We have been making brass hardware for 70 years. We think we've learned a few things about making and delivering hardware.

- We have no minimum order size
- Hardware is always in stock
- Substantial quantity discounts

Please call or visit us online.

www.horton-brasses.com

800-754-9127
49 Nooks Hill Road
Cromwell, CT 06416

Jig makes it easier to plane sides of drawers

It usually is necessary to plane the sides of an assembled drawer to get a perfect fit in the drawer pocket. But it can be a chore to hold the drawer in place for that task.

The typical routine requires that you clamp the drawer to the side of a bench, take a pass with the plane, unclamp the drawer, check the fit, reclamp, take another pass with the plane, and so on.

This simple jig saves time and effort. It consists of two main parts: a yoke that mounts in the end vise and a support board that clamps to the workbench.

Once the jig is set up, you simply slide the drawer in place and plane. Slide the drawer out to check the fit. The jig provides support so that the sides stay flat. It also holds the drawer in such a way that I don't feel like I'm stressing the corner joinery.

The yoke is a rectangular piece of $\frac{3}{4}$ -in.-thick plywood. A 1-in.-wide slot cut in the yoke accepts either the drawer front or back. Attaching a hardwood cleat to the underside of the yoke allows it to be clamped in the vise.

The support board has slots on each side to accommodate drawers of different depths. I hold it in place by sliding a clamp through one of the benchdog holes, which keeps the clamp clear of the planing area. A bench hook also would work. By

flipping the piece end for end and moving the clamp to different benchdog holes, I can fit drawers of almost any width or length. If I can't, I just cut a new slot in the plywood.

—MARK EDMUNDSON, Sandpoint, Idaho

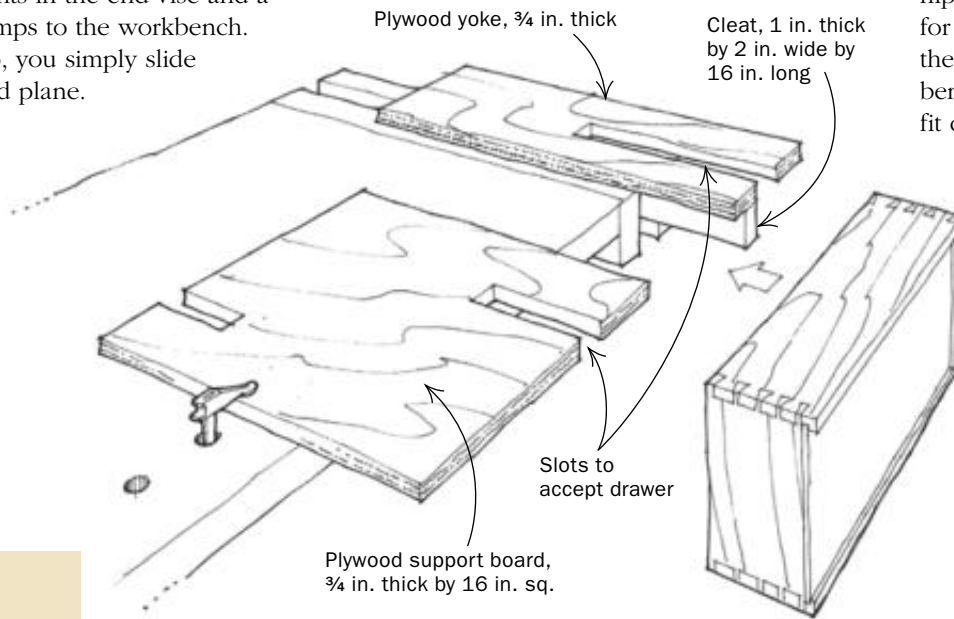

Extra

A lot of woodworkers fill smallish dings, dents, and splits with homemade putty made from sanding dust and wood glue. To make the putty less visible, I go a half-step further and use dust from the same species of wood that's getting filled. To ensure a ready source of different types of sawdust, I store dust from several common wood species in individual containers. A sawdust source is never a problem; I just empty the dust-collection canister on my random-orbit sander after using it on a particular species of wood.

—MICHAEL WILSON, Tuscaloosa, Ala..

Improved tabletop button fits slot every time

An apron slot that's a little too high or low won't make a difference to this tabletop button. A kerf under the working end of the button gives it the flexibility to bend up or down as needed to slip into the slot.

—PETER WALLIN, Malmö, Sweden

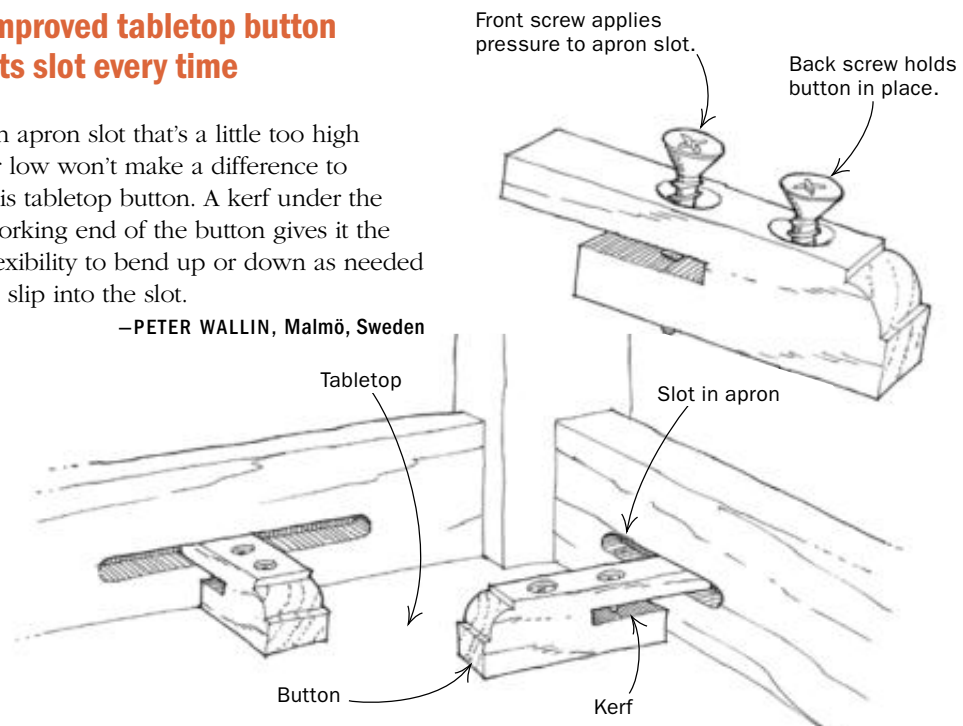

Nature Made It.



Minwax® Makes It Beautiful.



Wood adds natural warmth and beauty to your home. Especially when it's finished with Minwax®. From warm, rich wood stains to protective, clear finishes, Minwax offers a complete line of easy-to-use, quality wood finishing products. Trust Minwax to make and keep all your wood beautiful for years to come.

minwax.com

©2007 Minwax Company. All rights reserved.



Makes And Keeps Wood Beautiful™



PROUD SPONSOR

Get answers fast at FineHomebuilding.com

FineHomebuilding.com offers online members fast access to trusted, expert information—plus a new level of interactive features to complement what's in our magazine:

- Over 2,000 of our best articles and tips
- Instructive on-demand videos
- Informative blogs from editors and authors
- Online forums for information sharing
- In-depth coverage of green building

Most importantly, FineHomebuilding.com is specifically designed by our editors to streamline and speed the search process so you'll always find trusted answers fast.



Drill-down search locates the exact information you need quickly.

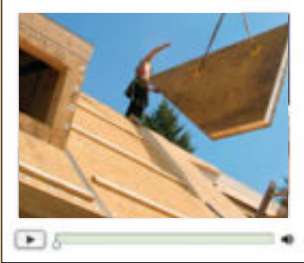

On-demand videos show how every step is done by pros.



See for yourself, visit today!

FineHomebuilding.com/Explore

Lie-Nielsen
TOOLWORKS[®]
INC.

Heirloom Quality Tools[®]

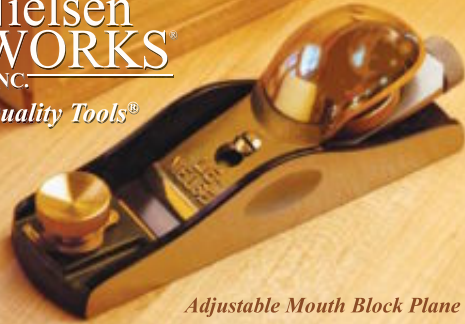

1-800-327-2520

www.lie-nielsen.com

P.O. Box 9 • Warren, ME 04864

Adjustable Mouth Block Plane

www.curiouswoods.com

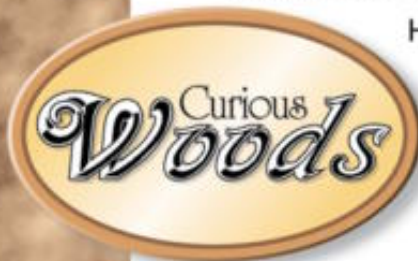

Hand selected native and imported hardwoods, turning stock, burls, furniture grade plywood, veneers, and fine finishing oils.

SUPERIOR QUALITY HARDWOODS
for SUPERIOR RESULTS

WOOD COMPONENTS



1020
29 x 2 7/8

1456
34 1/2 x 3 1/2

1425
36 x 7 x 7 1/2

1450
34 1/2 x 3 1/2

8010
93/4 x 4 1/2 x 5 1/2

4100
4 3/4 x 3 3/8

4002
4 x 3 3/16



ORDER ONLINE:
www.WoodenComponents.com
ORDER LINE:
1.800.849.8876
CALL FOR A CATALOG:
1.800.746.3233

4620 GA Highway 123 • Toccoa, GA 30577 • E-mail: info@osbornewood.com

THE LATEST & POSSIBLY GREATEST CHOICE IN SAWS FOR THE HOME WORKSHOP

MODEL 50-220 : 10" LEFT-TILT "HYBRID" TABLE SAW

- Unique digital bevel display
- Solid one-piece yoke
- Large stop switch
- 3 fence options including, made in Canada General T-fence, with either 30" or 50" rails
- Full cast-iron table 44" x 27" (with extensions)
- Dual direct dust collection includes built-in blade shroud connected to a standard 4" dust outlet
- Onboard storage brackets for fence & miter gauge

For current promotions, complete product info and a list of dealers near you:

WWW.GENERAL.CA



getting started

Living with wood movement

SHOP ENVIRONMENT IS THE KEY

BY GARRETT HACK

When I was still wet behind the ears as a furniture maker, I once built a tabletop that shrank so much against the breadboard ends that it cracked. I hadn't taken into account the amount of shrinkage the top would experience in the dry air of the first winter. As it tried to shrink against the breadboard ends, two fine cracks opened up. It didn't matter how old the wood was or if it was kiln- or air-dried, it was doing what wood forever will do—shrink and swell as it loses or absorbs moisture from the atmosphere.

Despite modern glues, well-engineered joinery, and sealing finishes, wood's moisture content demands attention if you want your work to last. Out of necessity, I've developed strategies for dealing with moisture content as I'm seasoning the stock, milling the wood, and building my furniture.

Seasoning and milling the stock

When lumber arrives in my shop, I stack it loosely on end against a wall or on horizontal racks with stickers between the layers so that air can move through the pile. Then I leave it alone. The simplest way to reduce potential moisture problems is to let the wood acclimate to the shop well in advance of starting a project.

In the winter, softwoods can acclimate in a week, and dense hardwoods in a few weeks. If I need to speed the process, I rough-cut parts and stack them in the gentle warmth above my shop heater. Even in the summer, when the atmosphere is at its most humid, the wood dries further. The longer it adjusts, the better.

For a long time I have relied on empirical methods that I'm sure past cabinetmakers also used. Dry wood feels warm, and produces more crumbly plane shavings than wetter wood. For thick stock, I drill into a waste section to see if the borings seem dry.

Only recently have I also begun to use a moisture meter to know exactly how quickly the final drying is progressing. A simple meter that uses two pins inserted into the wood surface costs about \$125.

My milling strategy is aimed at producing stable parts with the same moisture content inside as on the surface. Wood not fully acclimated, especially thick stock, can be wetter inside than out. A few days of rain, however, and very high humidity, can leave



STEP 1: LET NEW STOCK ADJUST TO YOUR SHOP

When bringing wood into the shop, allow the moisture content to balance with shop conditions. The easiest way is to stack boards vertically (above) or horizontally on racks in the shop for a few weeks. A moisture meter can be used to check the seasoning process by comparing readings from newly arrived stock (top right) with an average reading from boards that have already acclimated to the shop (bottom right). Finally, mill stock in stages. Leave extra material when ripping boards to width (below) or surfacing them with the jointer and planer. Variations in moisture content within boards can cause them to warp after milling. Excess material allows room to correct this later.



“We specialize in the finest examples of domestic and exotic veneers as well as burls, crotches and highly figured woods.”



berkshire veneer
COMPANY INC

Selling The World's Finest Veneers Isn't Our Job, It's Our Pleasure.

29 LOCUST HILL ROAD | GREAT BARRINGTON, MA 01230 | info@berkshireveneer.com
TOLL FREE: 1-877-836-3379 | PHONE: 413-644-9696 | FAX: 413-644-9414

Free Catalog

Furniture Parts
Ready-to-Finish

Call 800.843.7405
tablelegs.com



CLASSIC DESIGNS
by MATTHEW BURAK

SOLUTIONS FOR THE SERIOUS WOODWORKER

Inside Passage School of Fine Woodworking

A school founded on the teachings of James Krenov



Nine-Month Craftsman Program
One to Six-Week Artisan Programs

Weekly Lectures by James Krenov

Located on the Sunshine Coast of British Columbia

www.insidepassage.ca

1 877 943 9663

MISSION ACCOMPLISHED!

Tool No. 55438

"When making Mission Style doors Amana Tool® is the source for door making bits. We offer every type of door making bit you'll ever need including our innovative InStile and Rail set shown here. The InStile & Rail set allows you to adjust the groove to fit today's undersized plywood. No more annoying panel rattle. Amana Tool® also offers a complete selection of Panel bits."

Lonnie Bird

Amana Tool®
High Performance Cutting Tools

www.amanatool.com



Visit our new
Ask Lonnie Bird
question and answer column at
www.amanatool.com

For a dealer nearest you call (800) 445-0077

FOR THE TOUGHEST JOBS ON PLANET EARTH.™



From building, to creating,
to repairing and more.

1-800-966-3458 • GORILLAGLUE.COM

© 2007 The Gorilla Glue Company. G3HD



STEP 2: KEEP TRACK OF YOUR SHOP'S CLIMATE

To predict how furniture components will expand or contract in the future, it is important to know the working conditions in the shop. Hack uses scraps to create a seasonal barometer of wood movement (top). By tracking and recording this moisture board's width throughout the year, he can measure the board on any given day and assess the seasonal humidity of the shop. For tasks such as fitting a drawer, Hack consults the moisture board to predict how much the drawer front will expand and/or contract and to decide the amount of gap to leave along the drawer opening (bottom).

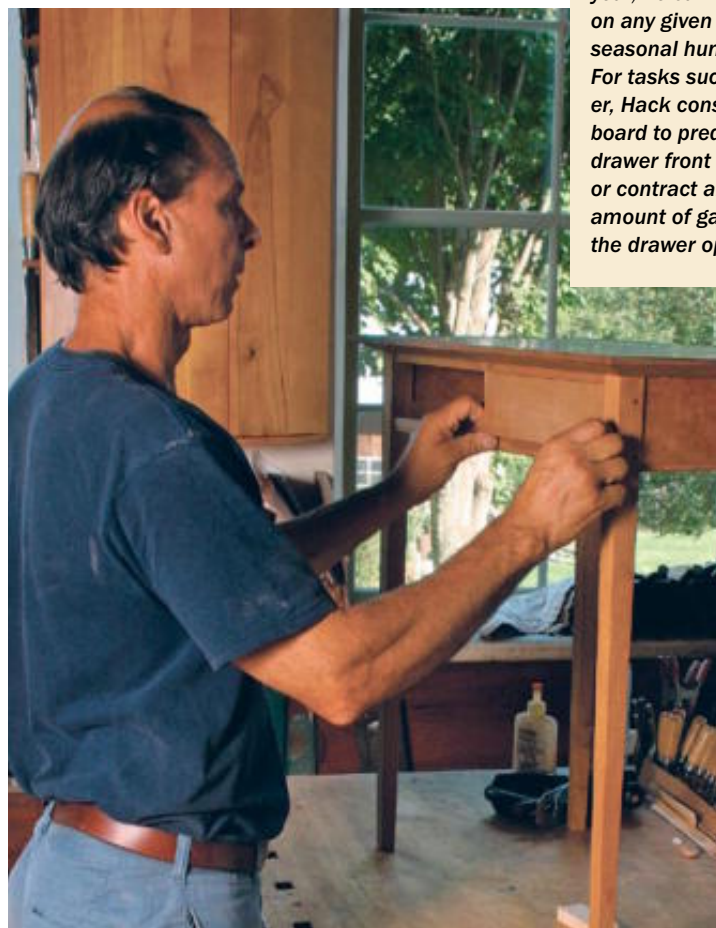

boards drier inside than on the surface. If I have time, I cut parts to rough dimension first and let them acclimate further for a few days. I do the same when I'm milling parts to their finished thickness. When planing, work both sides evenly and let the parts acclimate again. Planing only one side can cause moisture-induced warp.

Gauge and plan for seasonal movement

Even after careful seasoning and milling, wood's moisture content will continue to balance itself with the relative humidity

in the surrounding air, fluctuating with the seasons. This means that the same piece of wood can have slightly different dimensions at different times of year or if moved from the shop to an environment that is markedly wetter or drier. It's important to know how to estimate these changes ahead of time and plan for them when building furniture.

The best way to predict how dimensions will change from season to season is to measure the wood movement in a board over the course of a year. For this purpose, I have a few "moisture boards" hanging in my shop. One is a wide, white-pine plank and another is a crosscut scrap from a cherry tabletop. I use the white pine to estimate the movement in drawer bottoms and case backs; its movement is similar to that of basswood and aspen, other woods I use for those tasks. Cherry moves much like other hardwoods.

I measure the boards' width throughout the year and mark the readings on the boards. Because they mirror what the rest of the wood in my shop is doing, as well as the moisture content highs and lows, I use them to gauge how tightly to fit drawers or panels in any season.

Here's how it works: When I'm ready to fit drawers into a case piece, for example, I consult the moisture board. If the board measures 14 in. wide at the driest time of year and $14\frac{1}{32}$ in. at the wettest, and measures $14\frac{1}{32}$ in. today, I know to expect a slight amount of shrinkage and much more expansion during the coming year. If the drawers are 7 in. wide, or half as wide as my moisture board, I can calculate fairly accurately how much movement to expect (about half of what the board says, or $\frac{1}{64}$ in. expansion and $\frac{1}{64}$ in. shrinkage). If I'm unsure, I tend to err on the side of a slightly larger gap.

Work with dry wood and heat your shop

I prefer to work with wood as dry as is practical, so that table-tops or case sides will expand slightly before any shrinkage occurs. If the parts expand first, they can work against any tight fasteners and create some slack for later contraction.

On the other hand, on frame-and-panel work such as cabinet doors, I don't worry so much about a little excess moisture. I'd rather have the panels shrink a little instead of expanding and blowing out the joints.

To help avoid dramatic changes in climate when moving a finished piece from my shop to its destination, I heat my shop as I do my house. This results in a moisture content somewhere between 7% in winter and 11% in summer. Also, a good finish will slow moisture transfer (but won't stop it).

There are a variety of ways to outfit a shop with heat, but if this isn't practical, you could always store your lumber in the dining room—if you can get away with it. □



**Quality
Cabinet Doors,
Dovetail Drawer Boxes, and More...**



Ph.(701)839-3384 • Fax(701)852-6090
email: info@scherrs.com

www.scherrs.com

SPECIALIZING IN EXOTIC HARDWOODS OF THE WORLD



TOLL FREE 877.672.5275 cookwoods.com

RECEIVE 5% OFF YOUR FIRST ORDER WITH THIS CODE: FWWT

Forrest Blades

For building cabinets and fine furniture, nothing beats Forrest saw blades.

Craftsmen appreciate the way our blades deliver smooth, quiet cuts *without* splintering, scratching, or tearouts. They know our unique grade C-4 micrograin carbide, proprietary manufacturing process, and hand straightening produce exceptional results. In fact, independent tests rate us #1 for rip cuts and crosscuts.

"From the first cut on, I realized that this blade was a bargain at any price! Nothing else I have cuts comparably."
Calvin Brodie, Spanaway, WA

Forrest Quality Shows

Woodworker II—Best rated, all-purpose blade for rips and crosscuts

Chop Master—Perfect for tight, perfectly cut miter joints without splinters.

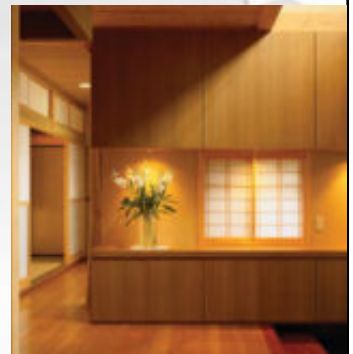

Order from any Forrest dealer or retailer, online, or by calling directly. Our blades are manufactured in the U.S.A. and backed by our 30-day, money-back guarantee.

FORREST
The First Choice of Serious
Woodworkers Since 1946

www.ForrestBlades.com
1-800-733-7111
(In NJ, call 973-473-5236)

© 2007 Forrest Manufacturing

Code FWW

RouterBits.Com



Over 800
Whiteside
Router Bits!

Email catalog@RouterBits.Com for a free print catalog!



NORTH-BENNET-STREET-SCHOOL
AN EDUCATION IN CRAFTSMANSHIP

Craft your own career

- in:**
- Cabinet & Furniture Making
 - Carpentry
 - Preservation Carpentry
 - Piano Technology
 - Violin Making & Repair
- Financial aid for qualified students. Accredited member ACCSCT. Non-accredited workshops 1 week to 3 months also offered.*

Boston • (617) 227-0155 • www.nbss.org

**Some dovetail
jigs promise you
everything...**

**The Keller Dovetail
System only promises
what it can deliver.**

Fast setup. No test cuts. Precision joinery. Unlimited widths. Classic and variable spacing. Compound, acute and obtuse angles. Curved dovetails. Box joints. Made in USA since 1976. 20-yr. warranty. 30-day money-back guarantee.

"Your best choice.

**It's the easiest of all the
jigs to use and great for
production use."**

-Woodworker's Journal

DVD OR VHS: \$8.95 + \$2 P/H



KELLER & CO.
1327 T Street, Dept. F57
Petaluma, CA 94952
1-800-995-2456
707-663-9336

www.kellerdovetail.com

Keller Dovetail System
Simple. Fast. Accurate. Enjoyable!

- Sanding Tools & Supplies
- Finishing Supplies
- Hardware
- Turning Tools
- Power Tools
- Glues & Clamps
- Craft Supplies
- Carving Tools
- Patterns & Plans
- Stationary Equipment
- Books & Videos

KLINGSPOR'S
WOODWORKING SHOP

"Quality Tools and Supplies for the Woodworker"

800-228-0000 • www.woodworkingshop.com

1,000's OF PRODUCTS AVAILABLE ONLINE

Three Bookcases

From simple to elegant, three approaches to building a home for your books

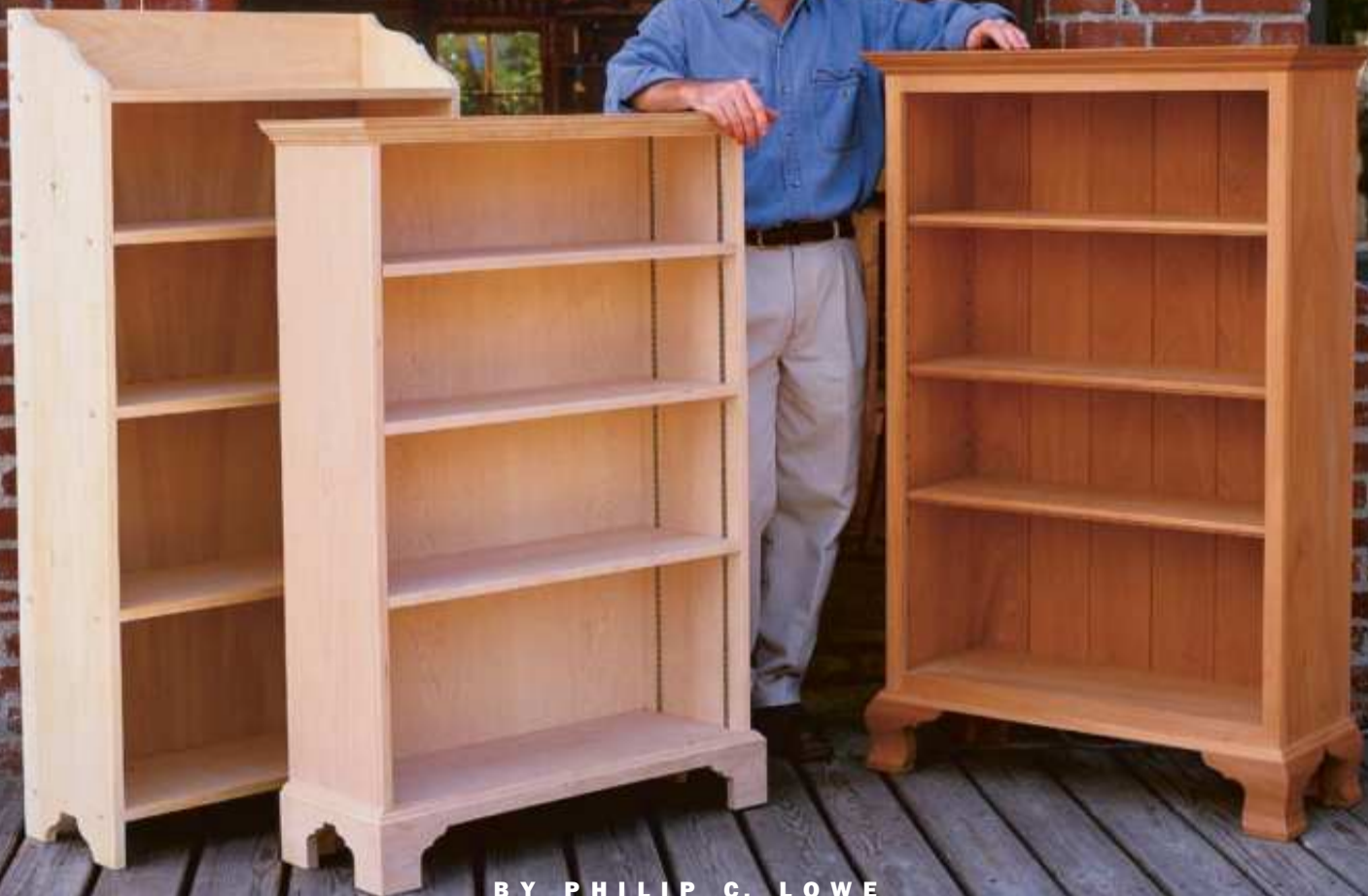

BY PHILIP C. LOWE

When customers inquire about having a piece of furniture made, it's part of my job to ascertain what quality of furniture they're looking for and to translate their desires into a dollar amount that will equal the time and materials needed to complete the piece. The quicker the joinery and construction and the cheaper the materials, the less expensive the piece. The woodworker building furniture in his or her home shop faces this same dilemma. Regardless of your skill level, you must first decide how much time and materials are worth putting into a piece.

Even if it's a project that's as straightforward as a bookcase, those considerations come into play. It's also worth thinking about

where the case will reside and what it will be used for, whether you want a simple piece that fits in most any room or an upscale design that fits well in a formal living room.

In this article, I'll show how to make three variations of bookcases: a simple but sturdy case made of premilled pine purchased at a home center; a case with adjustable shelves made from hardwood plywood with solid-wood facings and moldings; and a solid-wood case with elegant moldings and classic ogee bracket feet. I'll leave it up to you to decide which case is the right one for your time, budget, and circumstance.

Philip C. Lowe runs The Furniture Institute of Massachusetts.

Pine bookcase with classic lines

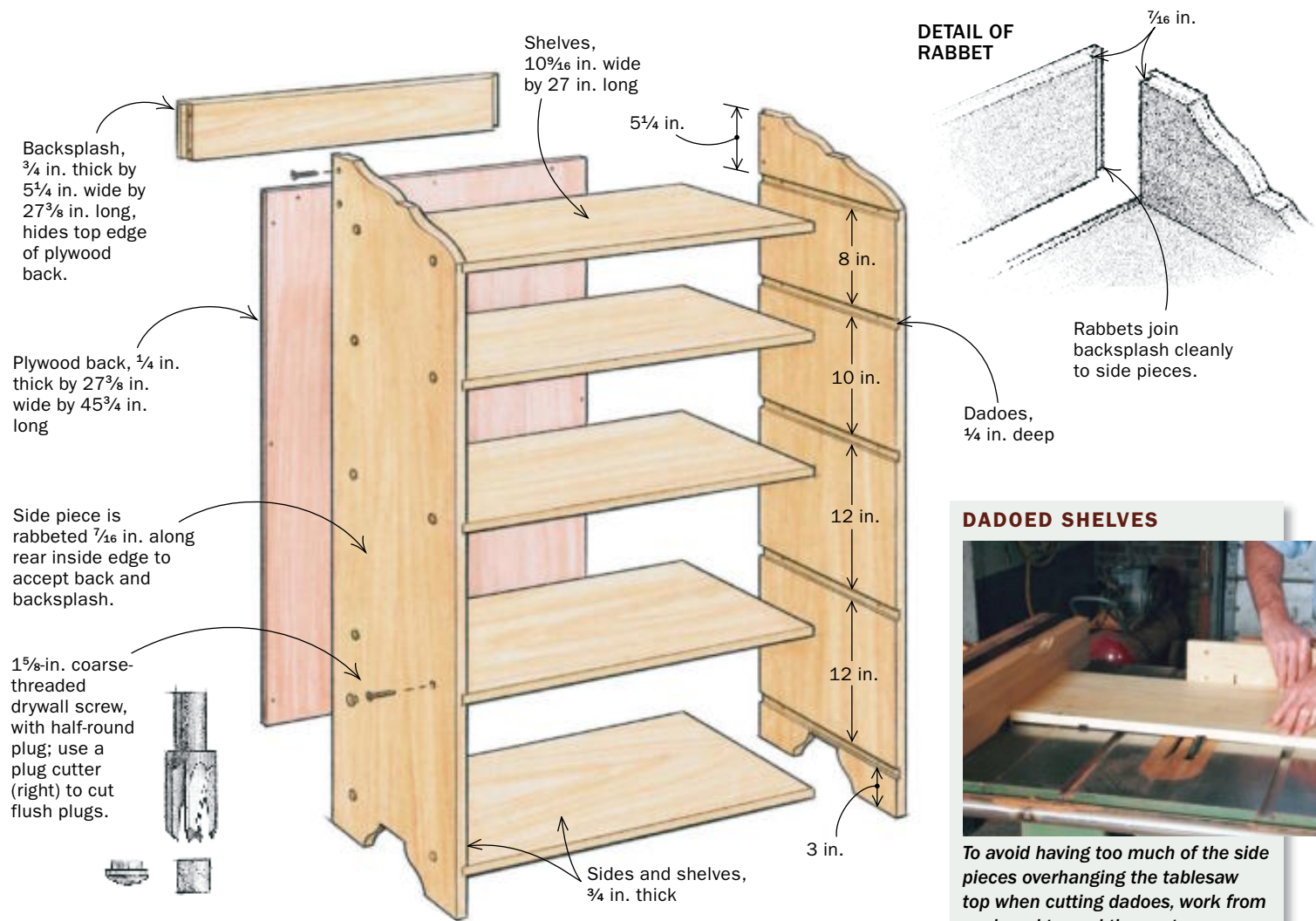

You can build a simple, functional bookcase in no time using 3/4-in.-thick stock from a local home center. Look for 1-in. by 12-in. clear pine, the boards that have the fewest knots. Make sure the boards are relatively free of cup, bow, twist, and crook.

Locating the shelves on each side piece is crucial. To make sure the dados line up properly, stack the side pieces on top of each other and mark each shelf location on the edge of both boards. You can cut the shelf dados with a router, but I prefer to use a dado set on the tablesaw so I can dial in the width of cut. Adjust the width of cut to match the thickness of the shelves. Rearrange the dado set to cut a 5/16-in.-deep rabbet along the rear edge of each side to accept the plywood

back. Lay out the decorative curves on the top and bottom of the side pieces using a compass or by grabbing a can, cup, or anything round that will form the shapes. Cut the curves with a jigsaw and clean them up with a file or sandpaper.

Before assembling the case, sand all of the parts and test the fit. When you're ready, run a bead of glue in each dado, set the shelves in place, drill pilot holes with counterbores, and drive in 1 5/8-in. coarse-threaded drywall screws. Screwing the back into position will square the case as the glue dries.

Finally, glue and screw the backplash above the back. Then plug the holes and trim the plugs flush. After a final sanding and the easing of all the sharp edges, the case is ready for finishing.

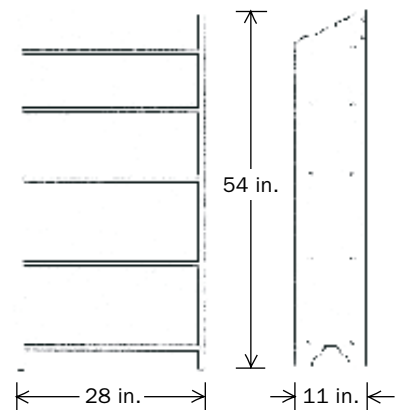

Dressed-up plywood bookcase

A hardwood plywood bookcase with adjustable shelves is a versatile, attractive piece. Preparing a scale drawing—with full-size details of the dadoes, rabbets, facings, and moldings—and selecting the right materials will help the process move along smoothly and efficiently.

A good-quality sheet of $\frac{3}{4}$ -in.-thick hardwood plywood won't be cheap—the curly maple sheet I used cost about \$200—but you'll only need one piece for this case. You'll need a couple of boards of solid wood for the facings and the base.

A tablesaw with a fine combination blade works well for cutting the parts from the sheet of plywood; it will leave edges with very few sawmarks. Rough-cut the solid lumber to length and width. The parts for the base should be planed to their finished thicknesses, but the parts that will become the facings should be planed only to within $\frac{1}{16}$ in. of their finished thicknesses. The facings will be scraped to the same thickness as the plywood after they are glued in place. When gluing the facings to the front edges of the sides and shelves, bar clamps and a long batten (strip of scrapwood the length of the shelf or side) will help you apply even pressure along the length. Once the glue has cured, cut away any extra length to even up the facings with the ends of the plywood pieces. Note that the extrawide facings applied to the top have mitered front corners.

Set a marking gauge to the thickness of the plywood, and scribe lines across the side pieces to locate the rabbets for the subtop. Scribe with a heavy hand so that the gauge will cut through the plywood's face veneer. The scored line has the added benefit of helping to prevent chipout as the rabbets are cut. Also, scribe lines across the sides to locate the dado for the bottom piece.

Cut the rabbets and dadoes on the tablesaw using a dado set. Use shims

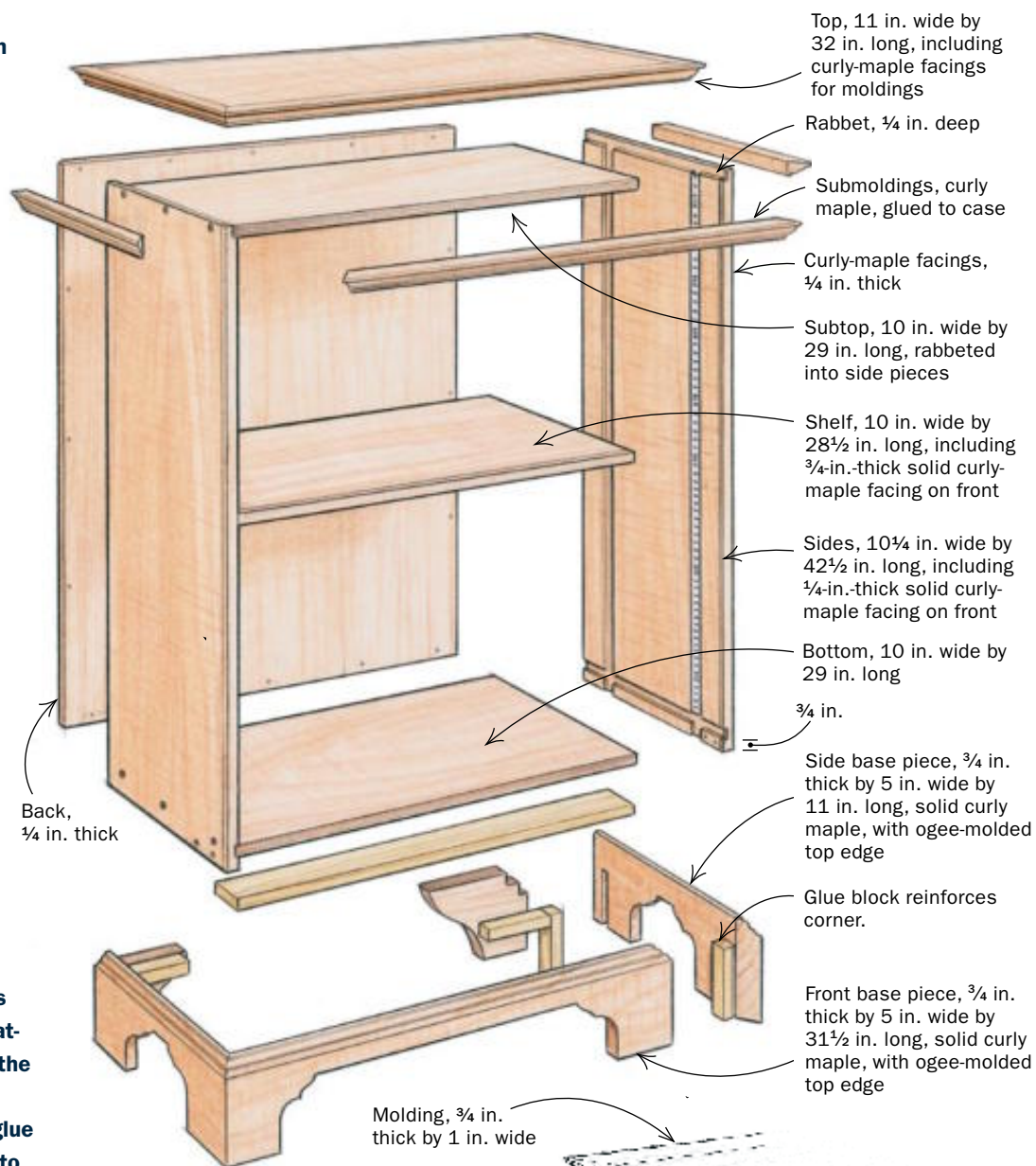

to dial in the exact width of cut. First, cut the rabbets and dadoes in the side panels for the top and bottom. Next, cut grooves from top to bottom for the metal shelf standards and then rabbets along the rear inside edges for the back.

The construction of the carcass, prior to adding the molded top and base, is similar to that of the bookcase on p. 19, in that dadoes and screws are used, but only to connect the top and bottom to the sides. Before the top and bottom are glued and screwed to the sides, lightly sand the exposed surfaces to their finished state (be sure you don't sand through the thin

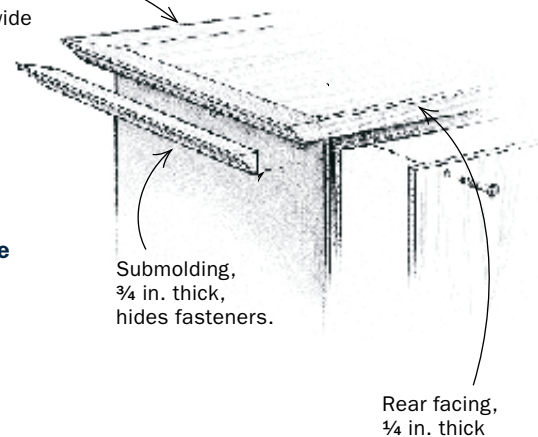



CONSTRUCTION OF THE BASE

A plunge cut is the surest way to cut a straight line between the curves at either end of the base. First, raise the tablesaw blade and mark the fence at the blade's farthest point. Retract the blade and position the base piece to the mark. Clamp a stop to the fence to avoid

kickback. Now, carefully raise the blade through the base piece (left), then push the base piece across the blade. Finish by cutting out the curves at the bandsaw (middle). Glue and clamp the front and side base pieces to the carcass at the same time (right).

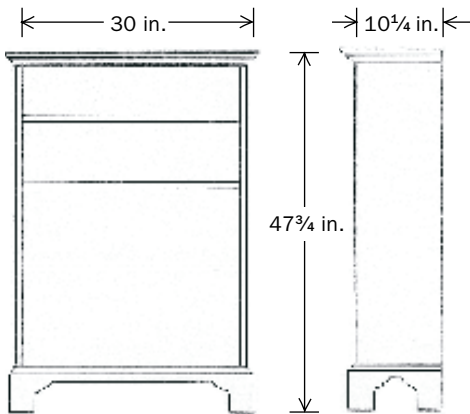

from breaking off if kicked. Glue the base to the bottom of the carcass and then install glue blocks in the inside corner of the joints to add strength.

Using a router, shape the molding around the top piece into the extrawide facings that have been applied. The plywood top has molding on the front and sides, and a solid facing on the back. It's safer to rout the molding profile after the strips have been glued to the top. The molded edge on the top piece itself is a cove and quarter-round, run with the quarter-round to the top. When molding a top with solid facings, it's best to make the

first cut across the left side, beginning at the front corner and working toward the rear. Make the second cut across the front, beginning at the right corner, and then the third cut across the right side, working from the rear to the front. This progression of cuts helps eliminate tearout at the corners.

The narrow submolding applied just below the top should be shaped on a wider board. Then you can rip the thin molding from that board. I shaped the edge molding on the base and the top submolding with the same ogee bit (when applied, the submolding is turned upside down).

hardwood veneer of the plywood). Now attach the top and bottom to the sides. Use 1 5/8-in. coarse-threaded drywall screws, countersunk to keep the heads of the screws below the surface. The screws will be covered by moldings.

The molded profile of the base is cut on the router table. It's safer and more efficient to cut the profile in one pass in a larger piece of stock. After routing the profile, cut the blank into three pieces, miter the ends, and test-fit the joints at the front corners. Then lay out the curves of the bracket feet. I made a plunge cut on the tablesaw for the straight section of the front base piece and cut out the curves on the bandsaw. At the rear of the base (see drawing, bottom right), cut a stop dado and install a bracket to help prevent the foot

CASE-BACK DETAIL

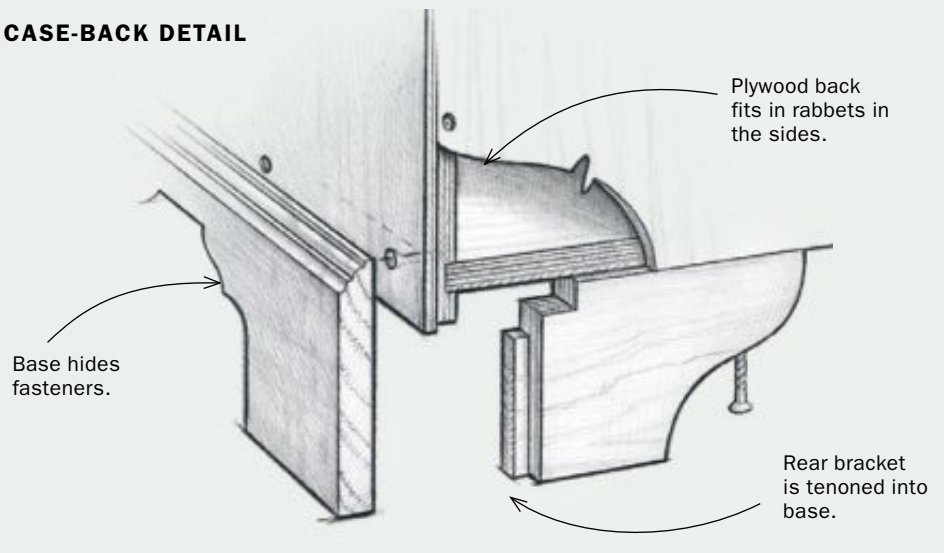

Mahogany bookcase with a period pedigree

With its elegant bracket feet and dovetail joinery, this mahogany bookcase is more challenging to build. But in the end, you'll have an heirloom piece that will last for generations.

Locking the carcass together with dovetail joints makes for a solid foundation onto which to attach the top, back, shelves, and ogee bracket feet. I used lapped dovetails to attach the top stretchers to the sides and to attach the rear bracket feet to the ogee bracket feet. The bottom shelf connects to the sides with sliding dovetails.

The face frame is of simple mortise-and-tenon construction. The top rail should be wider than the other pieces because a portion of it will be covered by the submolding below the top. A face frame gives the bookcase front a substantial appearance. The drawback is that books can get trapped behind the frame.

Begin by assembling the sides, stretchers, and bottom shelf, being sure to keep the case square. Next, apply the face frame to the front and filler frame at the bottom (the filler frame provides a mounting place for the bracket-foot frame). The filler pieces can be assembled with biscuits or mortise-and-tenon joints. Now assemble and attach the bracket-foot frame, which is a mitered assembly reinforced with splines.

The ogee bracket feet added to this case certainly elevate its design. The feet are made from one long blank. First, mark the shape on the end of the workpiece. Rough out the concave area. Raise the sawblade to the height of the concave curve and then position the blank diagonally until the blade fills the curve. Clamp a straightedge to the table, parallel to the piece, lower the blade, and take very light passes, biting off no more than $\frac{1}{16}$ in. at a time. If the blade starts to sing wildly, the cut is too deep or the pass across the blade is too rapid.

Once you've completed this series of cuts, remove the temporary fence and replace it with the regular fence. Angle the blade to 45° and set the fence so that the square corner at the top of the foot can be cut away by running the blank on its top edge. Then adjust the blade angle to $22\frac{1}{2}^\circ$ and cut a second bevel, taking away the sharp corner of the angle you've already cut. Cut at this angle two more times, first with the blank lying flat on the table, profile down. The second cut is made with the fence moved to the left side of the blade and the blank run between the fence and the blade. For this final cut, raise the blade to remove the hard angle where the cove meets the round.

Once all the tablesaw work is completed, clean up the curves using handplanes, scrapers, and sandpaper. Now cut the blank into three lengths, each long enough for two halves of an ogee bracket foot. Each front foot is formed from two halves mitered together; the back feet each have an ogee-shaped half dovetailed to a flat rear bracket piece shaped with a simple curve. Miter-cut four ends of the lengths for the front feet and leave two ends straight for the rear feet. Now glue the mitered sections together, dovetail the flat rear brackets to the ogee sections, then attach glue blocks to each section. You can then glue the feet to the mitered base frame.

Shiplapping is an excellent means of attaching solid boards to the back while allowing each board to move with seasonal changes in humidity. Determine the width of the boards by dividing the width of the opening by the number of pieces you prefer. I settled on six boards for this case. Each rabbeted board will hold down the board next to it if you position two screws (one at the top and one at the bottom) near the edge. Two screws will leave each board free to move seasonally. And if you've had books piled on the floor, the bookcase itself will provide you the same freedom!

MAKING THE OGEE BRACKET FEET



Cut the concave section first. Mark the profile on the end of the workpiece. Next, adjust the blade height and angle of the workpiece to match that profile. Clamp a fence to the table at the correct angle, lower the blade completely, and then raise it $\frac{1}{16}$ in. per pass.



To shape the convex curve, set the blade at an angle. Make successive rip cuts, adjusting the blade angle each time. For stability, be sure to use a tall auxiliary fence.



Refine the curves. At the bench, shape and smooth the curves, first with a plane, then with a scraper, and finally with sandpaper. When you're finished, cut the sections to length.

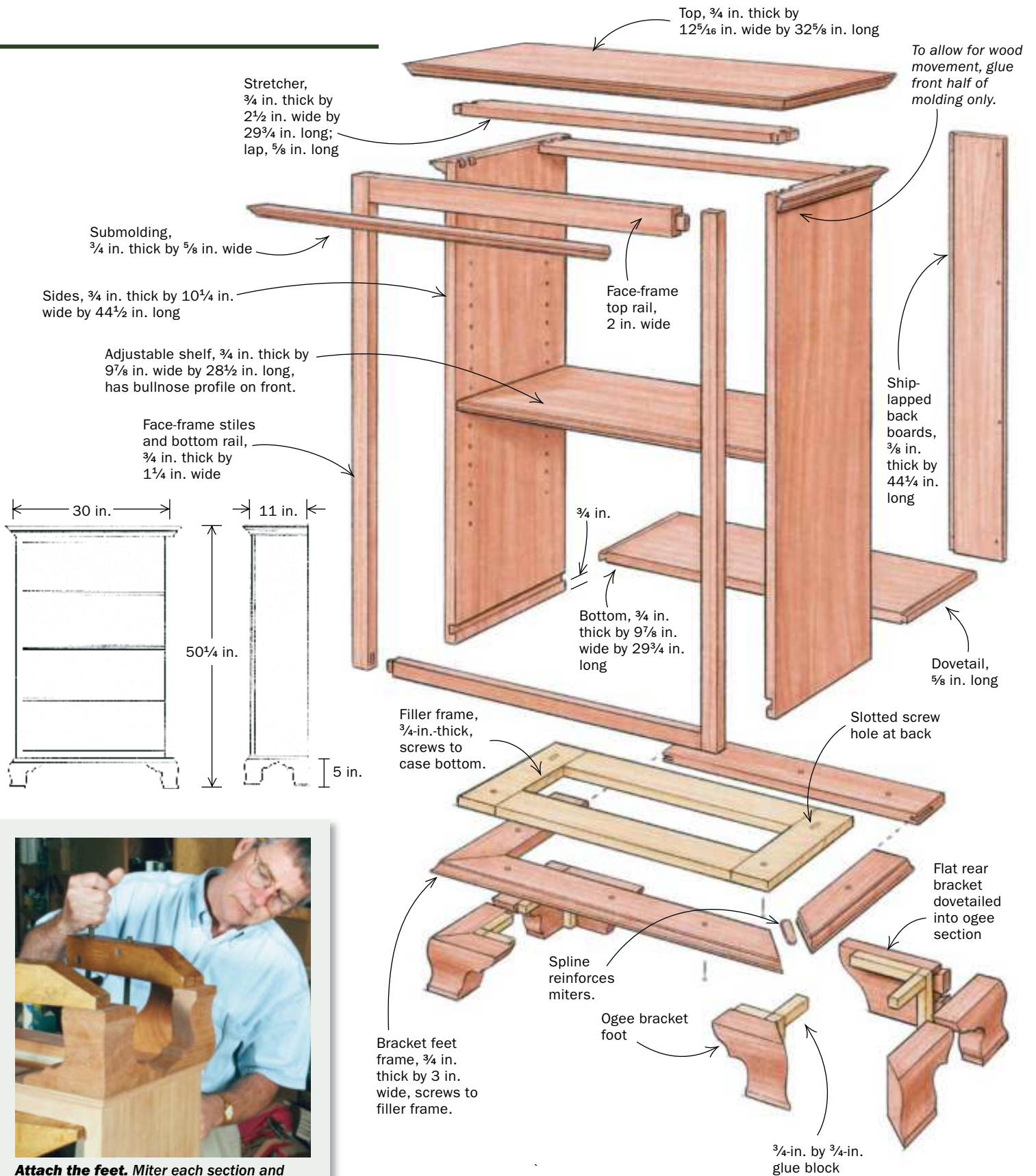

Attach the feet. Miter each section and glue the halves to each other, then the whole foot to the bottom of the case. Add glue blocks as reinforcement.

Sturdy Shelves

How to build shelves that won't wilt under load

BY JEFF MILLER



Everyone can use a few more shelves. Indeed, in many homes, an available shelf can be as difficult to find as the TV remote. So if you build a set of bookshelves, they'll probably be filled as soon as the finish dries.

Bookshelves can work in any room. You can make them free standing or built-in. They can be big or small. And they can take any form, from simple screwed-together and painted plywood for use in a utility room, to sophisticated formal library shelves made from beautiful hardwoods.

Shelves should look good

A successful bookshelf design must achieve a balance between appearance and function. A shelf with the perfect look might not be adequately strong. That often means making changes as you work out the design.

A good approach is to start by writing out a wish list that summarizes your ideal shelf design. The list should include the shelf depth, determined by the width of the books or other cargo going on the shelf. Next, choose a shelf length (bookcase width). Then, choose a shelf thickness— $\frac{3}{4}$ -in. stock is readily available, but let your eye make the final determination. After that, decide if you want the shelves to be fixed, adjustable, or some of each. Finally, choose a joint or mounting system that offers the look you want.

The design process is just beginning once you've worked out your bookshelf design "brief." Now you must determine

if your initial choices will be strong enough. If not, you'll have to make some design changes. But before we get to that, it helps to understand how a shelf reacts to load.

Sag is the main enemy

As the load on a shelf increases, the weight eventually reaches a point where the shelf bends, or sags. The same factors that affect appearance also affect shelf sag: the thickness, width, and length of the shelf; the wood species used; and the method used to mount the shelf.

As a general rule, our eyes won't notice sag if it's less than $\frac{1}{32}$ in. (0.031 in.) per foot. With time, even if the contents don't change, a shelf's initial sag could increase by 50% or more as the wood relaxes. Wood engineers call this "creep." To be safe, design shelves to limit any initial sag to no more than 0.02 in. per foot under a load of full-size books (see chart, below right).

In extreme cases (loading a bookcase with your anvil collection, for example), shelves can deflect so much that the wood actually fails. This is not a common worry. More common, especially on long shelves, is that sag causes the effective length of the shelf to become shorter, causing it to slip off the shelf supports. Or, too much weight on a long shelf can cause some adjustable shelf supports to crush the wood fibers in the case sides. As a result, the supports tilt downward.

Fixed vs. adjustable

The method used to mount a shelf affects how much it will bend under a load. All else equal, a fixed shelf will bend less than an adjustable shelf. That's because on a well-secured fixed shelf, the ends resist both tilting and being pulled inward by the sag (see pp. 26-29 for fixed- and adjustable-shelf options).

Be aware that fixed shelves aren't immune to failure. With enough weight (perhaps adding your spouse's anvil collection to your own on the same shelf) and its consequential sag, even fixed shelves can fail at the ends. When that happens, the shelf curves and effectively shortens, the ends pull free, and everything can head south in a hurry.

Jeff Miller builds furniture and teaches woodworking in Chicago.

Design shelves for maximum load

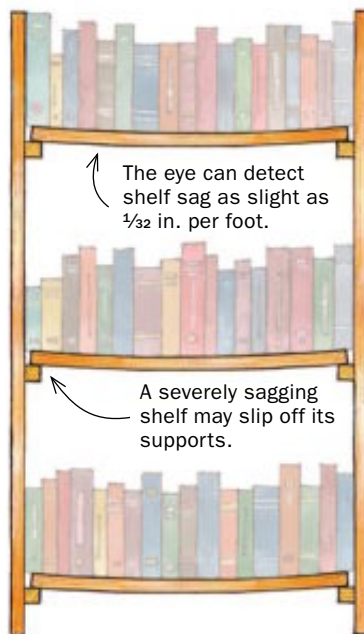

You don't need to guess at how much a shelf is going to sag. The chart below provides a quick way to determine if a shelf will be sag-free. If the chart doesn't work for your shelf, you can use the Sagulator, an online program that makes it easy to determine sag. Both the chart and the Sagulator assume unfixed shelf ends. Fixed ends sag less.

The chart is easy to use. It provides the maximum shelf-weight limits (in pounds per foot) and works for most designs. You need to know the thickness of the shelf ($\frac{3}{4}$ in. or 1 in.) and its length (24 in., 30 in., 36 in., or 42 in.).

If the expected load exceeds the weight limit shown in the chart, you'll have to make compromises. To do that, use the Sagulator

(www.finewoodworking.com/sagulator).

An answer of more than 0.02 in. per foot of shelf means you need to put less load on the shelf; use a stronger wood; make the shelf thicker, wider, or shorter; or add wide edging. With the Sagulator, you can adjust those values and calculate a new sag number.

Approximate shelf loads
 Hardcover books (9 in. by 11 in.): 20 lb. per ft.
 Magazines (9 in. by 11 in.): 42 lb. per ft.



Material makes a difference. Some shelf materials resist sag better than others. Red oak is one of the better ones, eastern white pine less so. MDF makes a weaker shelf.

SHELF WEIGHT LIMITS (pounds per foot*)

TYPE		LENGTH			
Species	Thickness	24 in.	30 in.	36 in.	42 in.
RED OAK	$\frac{3}{4}$ in.	49	21	9	5
	1 in.	116	47	23	12
	$\frac{3}{4}$ in. with 2-in. edging	112	47	21	12
POPLAR	$\frac{3}{4}$ in.	42	17	8	4
	1 in.	101	41	20	10
	$\frac{3}{4}$ in. with 2-in. edging	97	39	20	10
EASTERN WHITE PINE	$\frac{3}{4}$ in.	33	14	6	3
	1 in.	74	32	15	8
	$\frac{3}{4}$ in. with 2-in. edging	76	32	14	8
FIR PLYWOOD	$\frac{3}{4}$ in.	32	13	6	3
	$\frac{3}{4}$ in. with 2-in. edging**	96	39	18	9
MDF	$\frac{3}{4}$ in.	9	4	2	1
	$\frac{3}{4}$ in. with 2-in. edging**	73	30	14	7

*Based on 11-in.-wide shelves **Edging is red oak; other edgings are the same wood as the shelf.

Fixed shelves sag less and strengthen the case

Fixed shelves attach to the sides of a case with either wood joinery, hardware, or a combination of the two. Unlike adjustable shelves, fixed shelves help strengthen the entire case. And because they are attached to the case sides, fixed shelves sag less.



DADO

Strength: Good

Appearance: Good (excellent if using a stopped dado—one that's not exposed at the front—or if covered by a face frame)

A dado joint houses the ends of the shelf in a long notch, providing some mechanical strength. But a dado joint connects mostly porous end-grain surfaces, and adding glue increases the strength only nominally. The attachment strength of a shelf can be improved by combining Confirmat screws (right) with either a dado joint or a rabbeted dado joint. The screws pull the ends of the shelves into the dado, while the dado shoulder (or horizontal surface) adds strength against shear.



RABBETED DADO

Strength: Good

Appearance: Good (excellent if using a stopped dado or if covered by a face frame)

A minor variation on the dado joint is to rabbet the ends of the shelf to fit into a narrower dado. The main advantage is the ability to fit the joint more easily, especially if the shelf thicknesses are inconsistent. This joint is useful when working with hardwood plywood, which typically measures less than $\frac{3}{4}$ in. thick. In this case, a dado cut by making a single pass with a $\frac{3}{4}$ -in.-dia. straight router bit ends up too wide. However, with a rabbeted dado, you cut a narrow dado first, then cut the rabbet for a perfect fit.

SPECIAL SCREWS ADD STRENGTH

I'm not a fan of screwing shelves in place with the typical tapered wood screw. They rarely hold up long-term. That said, I have found a specialized screw that works much better. Called a Confirmat screw, it has a thick body with sharp, deep threads. It's mainly used with particleboard, melamine, and MDF, but it also holds well in solid wood. When used in a dado or a rabbeted dado, the joint strength is excellent. Confirmat screws require a pilot hole and a shank hole. A special bit is available that does the drilling in one step (see "Sources of Supply," p. 29).



Rabbeted dado starts with a dado. A T-square jig helps cut a dado across the side. The slot in the jig is just wide enough to accept the bearing of a top-mounted bearing-guided straight bit.



Mark and cut the rabbet. First, mark the rabbet location on the end of the shelf (left), then use a bearing-guided rabbeting bit to cut the rabbet (above).

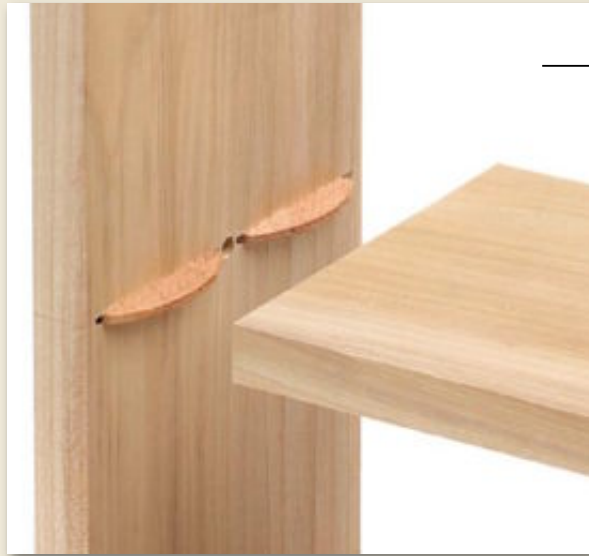

BISCUITS

Strength: Fair

Appearance: Excellent

It's easy to fix a shelf in place using biscuits. And, because the biscuits are hidden when assembled, there is no joinery, support parts, or hardware to distract the eye. Use at least two biscuits on each end of the shelf. Add a third if there's room. The jig shown at right is a good one to use here because it helps to align the biscuits horizontally from one shelf side to the other.



JIG ALIGNS BISCUITS ACROSS SHELF

This plywood jig helps to align biscuits accurately across the bookshelves. The plywood cleat keeps the end of the fence square to the side. Mark centerlines for the slots on the end of the fence. After cutting each set of shelf slots, cut the fence to a shorter length. Toss the jig when done.



SLIDING DOVETAIL

Strength: Excellent

Appearance: Very good (excellent if stopped or covered by a face frame)

A sliding dovetail adds considerable mechanical strength, but sliding a 10-in.-long dovetail into a tight-fitting slot before the glue sets up is a challenge. Using a fairly slow-setting epoxy glue will help considerably. Epoxy is a slippery glue that helps get this type of joint together without excessive expansion and stress.



SCREWED CLEATS

Strength: Very good

Appearance: Fair

Screwed cleats let you add shelves without too much fuss, but they come up a little short in the appearance department. With the exception of the hole closest to the front, all of the holes in the shelf should be slotted to accommodate wood expansion. For the same reason, if you wish to glue this joint, bear in mind that you should glue only the front inch or so.

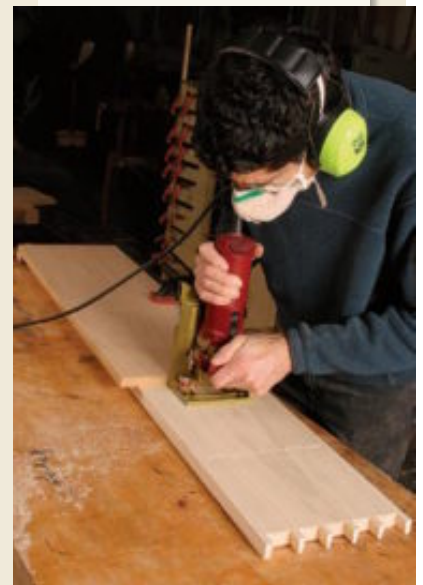

Clamp and cut. Clamp the jig to the case. Cut one set of slots, then use the jig to cut the same slots on the other side. Crosscut the fence to the next shelf position, and repeat until all slots are cut.

Adjustable shelves add versatility

Adjustable shelves make it easy to change the spacing as needs change. But there is a structural cost: These shelves do nothing to hold the cabinet sides together. So, on taller bookcases, it's a good idea to have one fixed shelf to help anchor the case sides.



SHELF PINS

Strength: Good (very good with sleeves)

Appearance: Good

Shelf pins come in a wide variety of shapes, sizes, materials, and finishes. My favorites are the machined solid brass ones from Lee Valley. I also like the very small round pins by Häfele for smaller cases. Shelf pins also come with special clips for securing the shelves or for holding glass shelves. Sleeves are a great way to recover from poorly drilled holes. Stamped sleeves (short tubes with a flared and rounded-over end) tend to look like shoelace eyelets when installed in a cabinet. Solid brass machined sleeves look better, even though they accentuate the row of holes in the case sides somewhat. Some sleeves are threaded for specially threaded shelf pins.



Sleeve adds refinement and strength. You can improve both the appearance and strength of a shelf pin simply by slipping a brass sleeve into the pin hole.

A JIG FOR PIN HOLES



Shelf-pin holes in a jiffy. Thanks to this shop-made jig, Miller quickly drills shelf-pin holes that are the same depth and perfectly spaced.



HIDDEN WIRES

Strength: Good

Appearance: Very good

These bent-wire supports fit into holes drilled in the case sides. A stopped kerf cut in the ends of the shelf slips over the support, hiding the hardware. Structurally, this means the end of the shelf is thinner. This affects the shelf's shear strength, but will have little effect on preventing sag.



WOODEN STANDARDS

Strength: Very good

Appearance: Very good

Wooden shelf standards have been around in various styles for generations. They are easy to make and add an interesting look to almost any bookcase. The style shown in the top-left photo (I call it zig-zag) is one of the more common forms.

Another style (I call it half-moon) is shown in the lower left photo. To make a pair, you'll need a piece of stock that's at least double the width of each standard. Scribe a lengthwise centerline along the stock, then lay out the shelf spacing by making evenly spaced marks along the centerline. Use a spade bit or a Forstner bit to drill a through-hole at each marked centerpoint. Finally, using a tablesaw, rip the stock down the middle. The net result is a pair of standards, each with a series of half-moon shapes.

Make the cleats just loose enough to slip in and out with ease.



METAL STANDARDS

Strength: Very good

Appearance: Fair

It's hard to beat metal shelf standards for ease of installation. Just run a pair of grooves down each side of the case, and nail, staple, or screw the shelf standards into place. Shelf supports usually just hook into place, although one new version has brass support pins that screw into threaded holes in the brass standards. In general, shelf standards seem out of place on finer furniture. But they are great for utilitarian pieces, and even in larger bookcases, where any support system will be pretty much invisible once the shelf is full of books.

ZIG-ZAG SUPPORT IN THREE STEPS



Start with stock wide enough to make four standards. Using the tablesaw, make a vertical cut at each shelf location (1). An auxiliary miter-gauge fence with a location pin in front (much like a finger-joint jig) makes it easy to position the stock for subsequent cuts. Follow with 45° cuts (2) after relocating the location pin. Remove the triangular waste piece, then clean the resulting flat with a chisel. Rip the stock to create four standards (3).

SOURCES OF SUPPLY

HÄFELE

www.hafele.com; 800-423-3531

LEE VALLEY/VERITAS

www.leevalley.com; 800-871-8158

McFEELY'S

www.mcfeelys.com; 800-443-7937

ROCKLER

www.rockler.com; 800-279-4441

Table Design

A well-proportioned table offers both comfort and style

BY GRAHAM BLACKBURN

The original and quintessential function of a table is to provide a flat surface for writing, playing games, eating, or working. And the form of any given table may be as varied as these uses. So it is of the utmost importance to be clear at the outset about the requirements of the table you intend to design, whether it's a small coffee table or large dining table. There are not only structural requirements—so that the table can do its intended job—but also ergonomic requirements. The most exquisite dining table will be a failure if it proves too small to seat diners comfortably.

Attention to function is absolutely the designer's first responsibility. Familiarize yourself with tables designed for similar functions, and note features designed for specific purposes, such as sturdy legs for

DINING DIMENSIONS

While it's important to make sure a table is sized to fit its intended space, these dimensions will get you close to a design that gives people elbow room.

COMFORT A CRITICAL FACTOR

Overall table height, legroom below the apron, overhang on the table ends, and the space allotted for each diner should all be considered when designing a dining table.

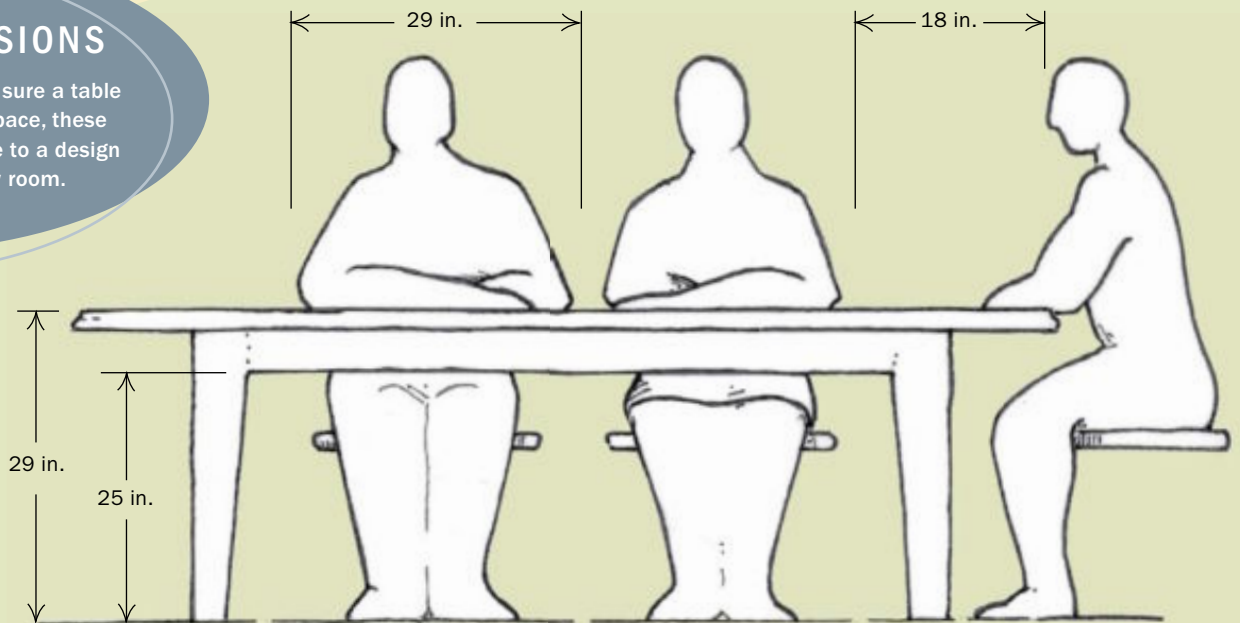
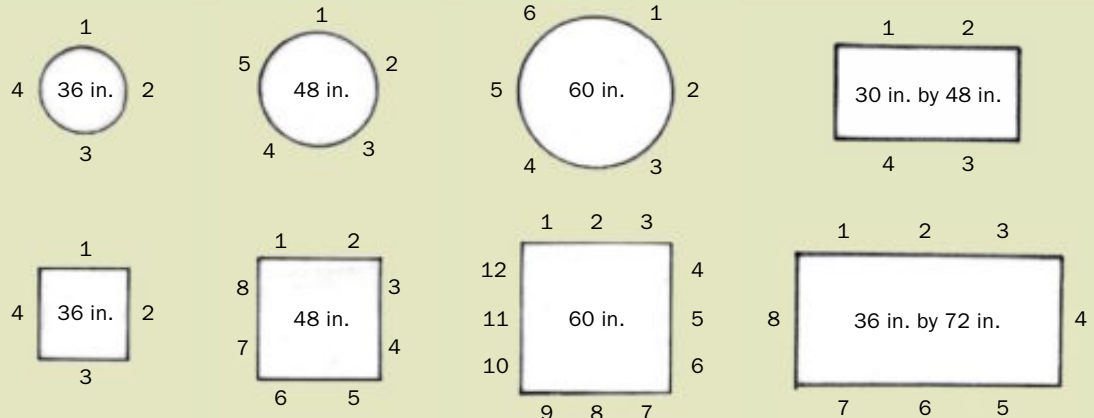

TABLE SIZE AND SEATING CAPACITY

While 29 in. of elbow room per person is ideal, it's not always possible. These examples give an idea of how many people fit comfortably around a given table size.



heavy loads, drop or draw leaves for tables that must expand, lipped tables designed to prevent objects from falling off, and drawers or shelves for storage. A reference such as *Architectural Graphic Standards* by Charles Ramsey and Harold Sleeper (John Wiley & Sons, 1998) is a useful place to explore table types by function and a basic reference for dimensions.

While your own experience and tools will dictate to a large extent how any given table is constructed, resist the impulse to build only what you are comfortable with. It is worth researching a new technique or a new joint for better function or a more pleasing shape.

At the same time, don't get carried away by the urge for novelty. Use appropriate species, relevant construction methods, the

right joint for the job—dovetail, mortise and tenon, dowels, biscuits, etc.—and a finish consistent with the intended use.

Legs set the style

To a great degree, all tabletops are the same. They're flat and intended to support something. While the wood species, the edge treatment, and the apron certainly can make stylistic statements, the legs most clearly establish a table's function and style.

It is possible to discern the function of the table by looking at the legs. Four heavy legs joined by a horizontal stretcher tell us that this is a library table intended to support a load of books. Light and gracefully tapered legs that focus attention on the tabletop, as if it were floating, suggest that

this may be a hall table for the display of some precious ornament.

Legs are frequently the key to identifying a table's style. For example, a Queen Anne table's top and apron are typified by restrained ornamentation. It is the cabriole legs that allow us to recognize the style. The same is true of the Shaker style, whose simple and efficient legs carry their load with no ornamentation or excess weight. And the Art Deco tables designed in the 1920s by Émile-Jacques Ruhlmann cast away traditionalism in favor of legs with sensuous curves.

Tie all elements together

Given that the functional requirements have been satisfied, and that the construction is sufficiently workmanlike, the most

OCCASIONAL TABLES

A coffee table should afford views across a room, while an end table should be a convenient height to someone seated in an armchair or sofa.

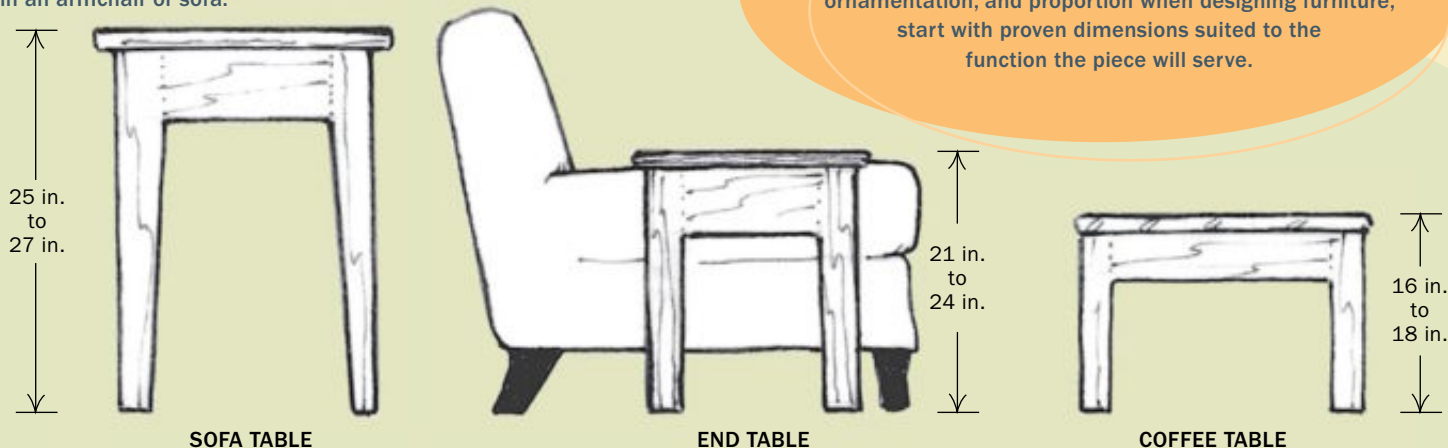
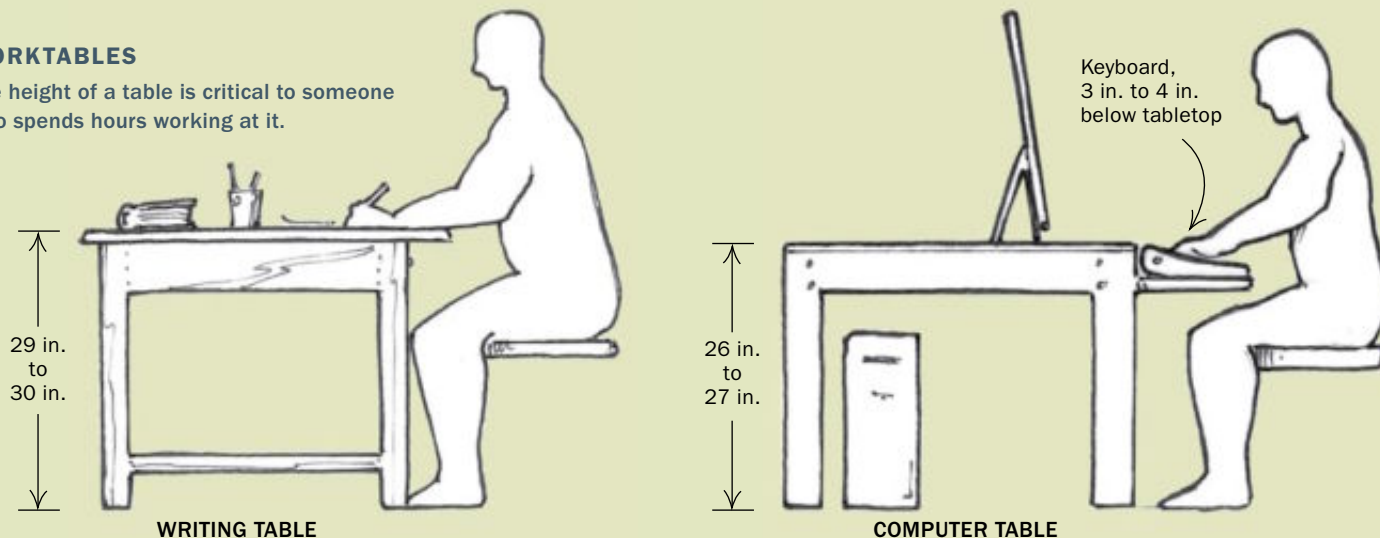

TABLE-HEIGHT GUIDELINES

Although there are endless possibilities regarding style, shape, ornamentation, and proportion when designing furniture, start with proven dimensions suited to the function the piece will serve.

WORKTABLES

The height of a table is critical to someone who spends hours working at it.



THREE PATHS TO PLEASING PROPORTIONS

A design rationale is crucial to building tables with pleasing proportions. The three described below are proven approaches, but others are possible.

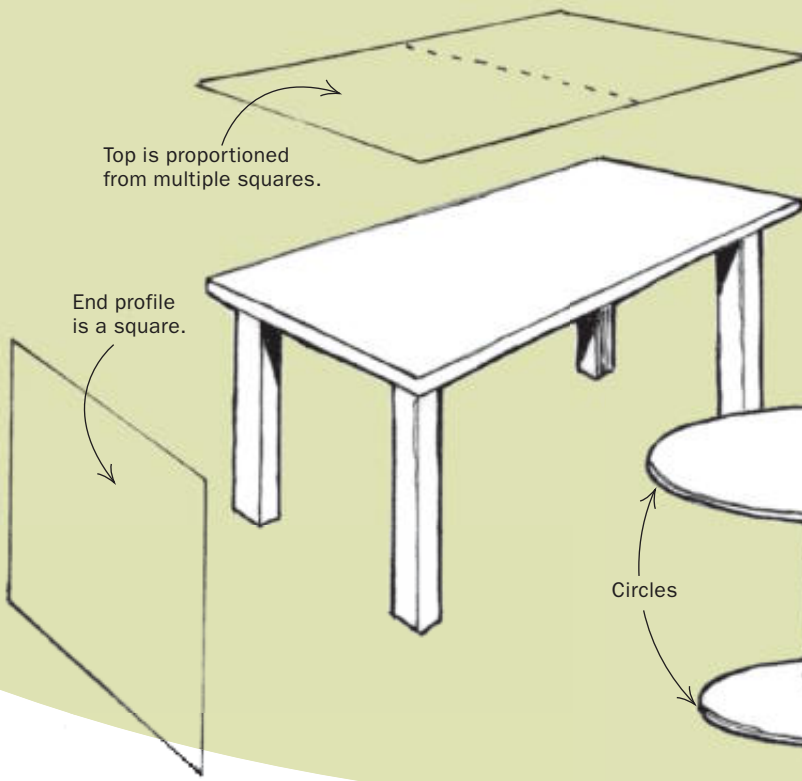

REPEATING GEOMETRIC SHAPES PROVIDE ORDER

Squares, cylinders, cubes, circles, ovals, or ellipses can be used to define both the overall shape and the details of a table, providing it with a repeated pattern that unifies the whole structure.

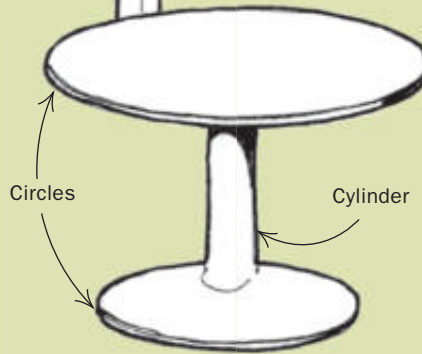

A NUMBER PROGRESSION IS A SUBTLE DESIGN DEVICE

Starting with a 1-in.-thick tabletop, for example, you might construct legs that measure 2 in. sq. and an apron that is 3 in. deep. Relating all dimensions to a common unit, either in multiples or regular increments, provides the table with an implied pattern that unifies components without being immediately apparent to the eye.

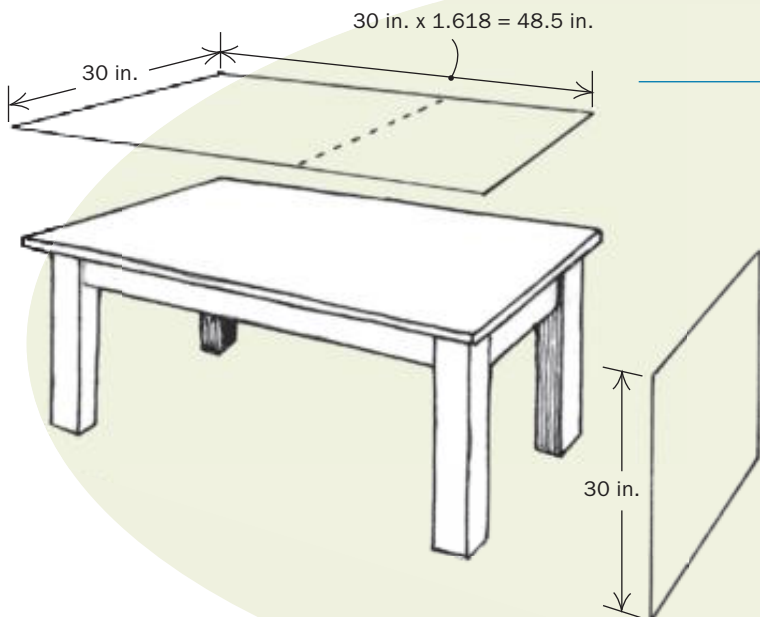
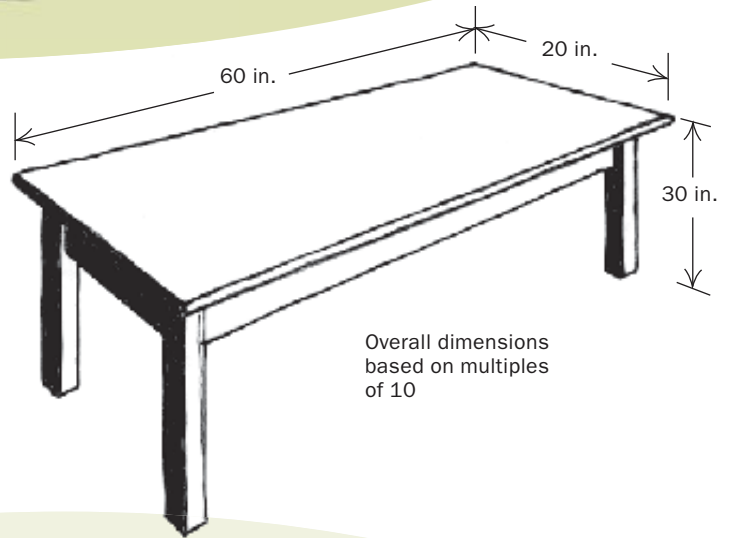
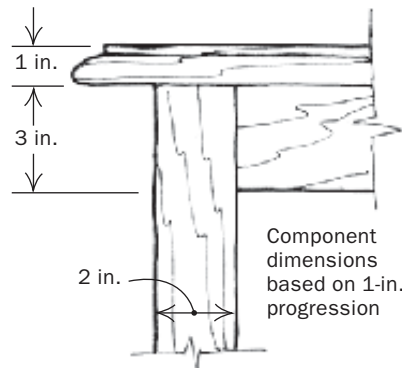

CLASSICAL PROPORTION SYSTEM PLEASURES THE EYE

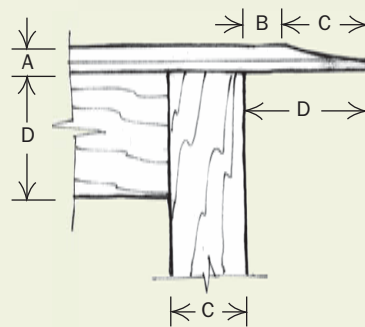

- A = tabletop thickness
- B = A x ϕ
- C = B x ϕ
- D = C x ϕ

The Golden Mean is the ratio of 1 to 1.618, represented by the Greek letter phi (ϕ). A tabletop might be designed so that its long side was 1.618 times longer than its short side. The ratio might also be used to determine the dimensions of the various parts of a table. The apron might be ϕ times the width of a leg, the leg ϕ times the thickness of the tabletop.

striking feature of any table is how well it fits in with its surroundings. This can mean designing in an established style such as Queen Anne or Arts and Crafts, or designing so that the general proportions, shapes, and colors are compatible with neighboring pieces. Compatibility can result from similarity or contrast. A severely modern design might fit very well with the relatively simple lines of a room full of Shaker furniture, but might look uncomfortably out of place in a room furnished in a ponderous Gothic or an ornate 18th-century style.

Designing in a particular period style can be difficult. It is not enough to employ superficial features of a period to achieve the right feeling. Slapping cabriole legs onto a table, for instance, does not guarantee that it will look “Chippendale.” Arts and Crafts furniture is not as uncompromisingly rectilinear as it may appear. And Shaker furniture, for all its apparent simplicity, is often surprisingly sophisticated in its proportions. Incorrect details can produce ludicrous and unhappy results, similar to applying a distinctive Rolls-Royce hood to a Volkswagen Beetle.

Before attempting to design a table in a period style, understand the typical construction techniques, the common materials, and the forms that governed the proportions. This last point—forms that govern proportions—is more important than almost anything else. The term simply means that, functional and structural requirements aside, some method has been employed to decide on all the dimensional details of your table. Making decisions about the exact width of a leg or the depth of a skirt or apron based on structural requirements alone may guarantee solid joinery, but your table may not look as balanced and graceful as it could if designed according to some plan.

There are, in fact, numerous paradigms commonly used by designers, some exceedingly simple, others sophisticated. You may, indeed, invent your own paradigm or plan—the point is that using virtually any plan is better than making decisions about exact dimensions based on nothing more than what material is conveniently at hand, or what size router bits are available. □

Graham Blackburn is a furniture maker and publisher of Blackburn Books (www.blackburnbooks.com) in Bearsville, N.Y.

TABLE-BASE OPTIONS

Not only must legs be appropriately sized to support the tabletop, they're usually the element that makes the strongest design statement.



SIMPLE LEG AND APRON CONSTRUCTION

For lighter-duty tables, the apron-to-leg joint (above) is stiff enough, and provides a light, graceful look. Stretchers add both physical and visual sturdiness to tables that bear heavier loads (right).

Apron-to-leg joinery
LIGHT-DUTY TABLE

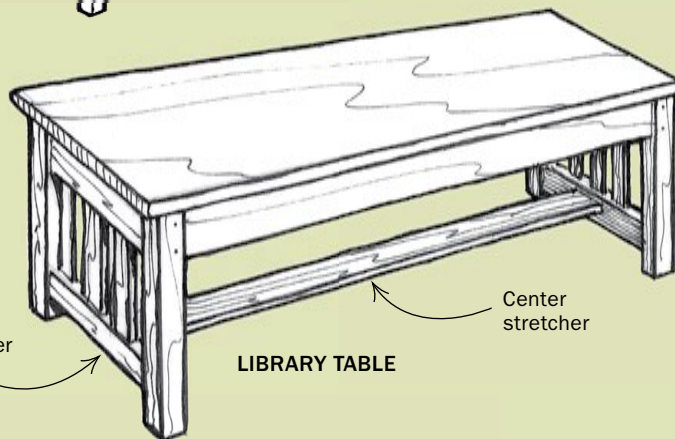

Side stretcher

Center stretcher

LIBRARY TABLE

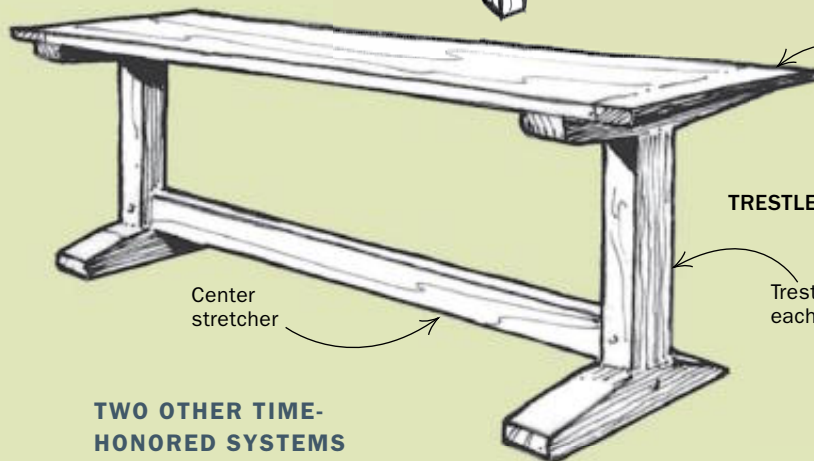

Center stretcher

Breadboard ends help keep the tabletop flat.

TRESTLE TABLE

Trestle at each end

TWO OTHER TIME-HONORED SYSTEMS

Dining tables must provide room for people to sit. Both the trestle and pedestal designs accomplish this by minimizing the number of table legs. The legs of trestle tables typically are set in from the end, making room all around for chairs.

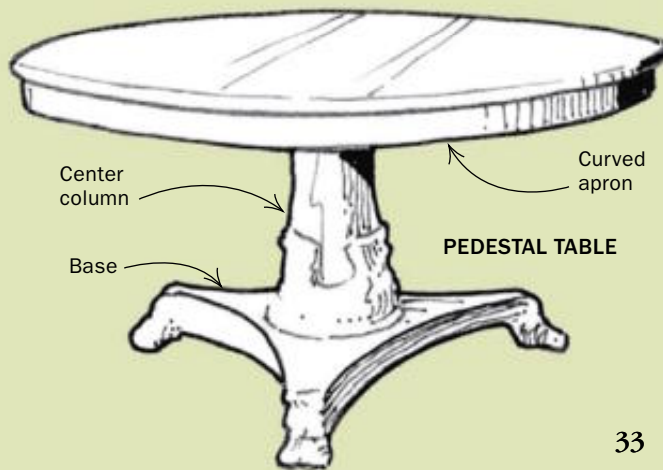

Center column

Curved apron

Base

PEDESTAL TABLE

Strong Joints

Build sturdier tables by beefing up the basic mortise and tenon

BY GARRETT HACK

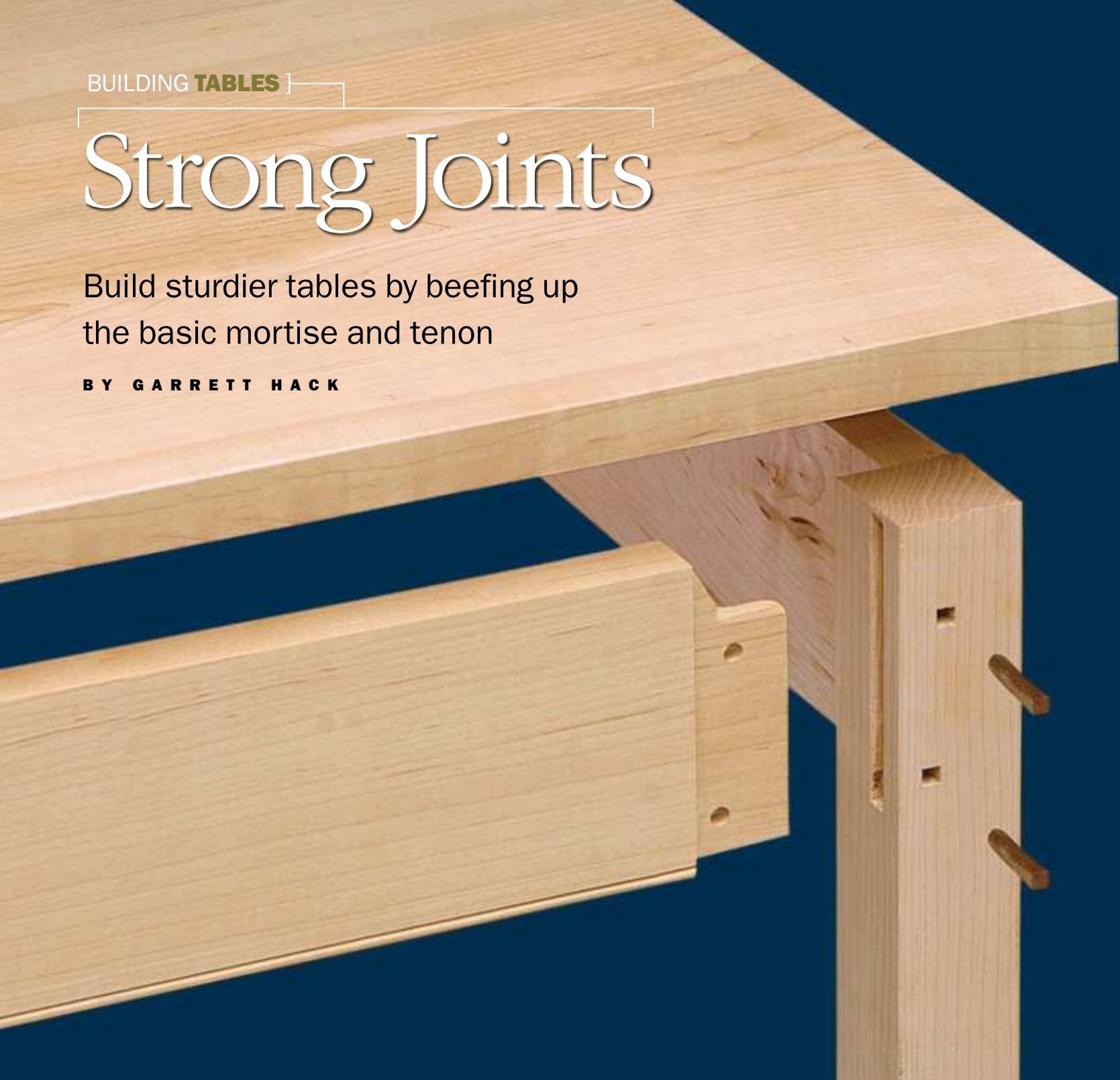

The life of a table is not easy. Legs get kicked; the table gets pushed and pulled across uneven floors, leaned against, and sometimes even sat upon. To make matters worse, the very nature of wood adds to the stress. As the tabletop shrinks and swells with seasonal changes in humidity, the movement works against the integrity of the table's structure. All that stress is felt in the leg-to-apron joint (above), which holds a table together and gives it rigidity. When the leg-to-apron joint fails, the table falls apart.

Leg-to-apron joints must withstand three different kinds of stresses: shear, bending, and twisting. Shear stress is caused by a vertical load directly above a joint, such as when someone sits on the corner of a table. Leaning heavily on the top of a table midpoint above the apron causes the joints to undergo a bending stress that tries to lever them apart. Shoving the table sideways or bumping against a leg gives the joints a mixture of twisting forces. Also, as a tabletop that is fastened too tightly to the apron expands or shrinks, it can try to twist the joints.

MAKING A HAUNCHED MORTISE



Use a plunge router with a fence. The plunge router will allow you to creep up on the full depth of the mortise by taking light passes. The fence will ensure accurate alignment of the mortise with each pass. For efficiency, size the mortise to a straight bit in your collection.

The best defense against these stresses is a well-designed, tight-fitting mortise-and-tenon joint that locks apron to leg. The mortise and tenon is not only a good joint for tables, but it's also widely used in the construction of all types of furniture, including cabinet doors and chairs.

Make tenons as thick and as long as possible

When deciding on the sizes of joinery components, the key is to attain a workable balance. Too large a mortise, and you risk weakening the leg; too skimpy a tenon, and you lose glue and mechanical strength. Ideally, you want the tenon to be as big as possible, with the joint located to maximize the mechanical connection. That means the shoulders on both sides of the tenon (which butt against the leg) must be substantial enough to resist bending and twisting forces.

When laying out the size and placement of tenons, a full-scale, top-view drawing will help you understand the orientation and relationship of all the parts and will help as you cut the joints.

Thicker tenons are better—You want the tenon to be as thick as possible. A good rule of thumb is to size the tenon thickness a little more than one-third the thickness of the apron. While the



Chisel the sloped section of the mortise by hand. This area, called the haunch, helps prevent twisting. When chiseling, leave the table legs long to keep them from splitting near the top.



Check the results using a small shopmade template. The template, cut to the angle of the haunch, makes it easy to check your progress as you chisel the top of the mortise.

one-third rule is a good general guide to follow, sometimes it's better to make exceptions. If I'm building a table out of a softwood, such as butternut, with aprons only $\frac{3}{4}$ in. thick, I make the tenons at least $\frac{5}{16}$ in., maybe even $\frac{3}{8}$ in. thick. Any smaller, and a sharp bump to the leg might snap the tenon right off. Because you rarely see the thickness of an apron, one good design strategy is to make it thicker— $\frac{7}{8}$ in. or 1 in. will provide larger, stronger shoulders.

Long tenons provide more glue surface—When it comes to tenon length, you want to create as much strong long-grain glue surface as you can. Naturally, a longer tenon has more glue surface along its cheeks (the wide faces of the tenon) and provides more mechanical strength to the joint. As a general rule, the longer the tenon, the better, assuming the leg it mates with can accommodate it without risk of damage. A tenon that's three to four times longer than its thickness is quite adequate.

Shoulders resist bending forces—When designing a mortise-and-tenon joint, look to create shoulders that are as large as possible and to have a shoulder on each side of the tenon (rather than one side only). Such a design is better suited to resisting bending stresses from either direction. The shoulders have the

A STURDY LEG-TO-APRON JOINT

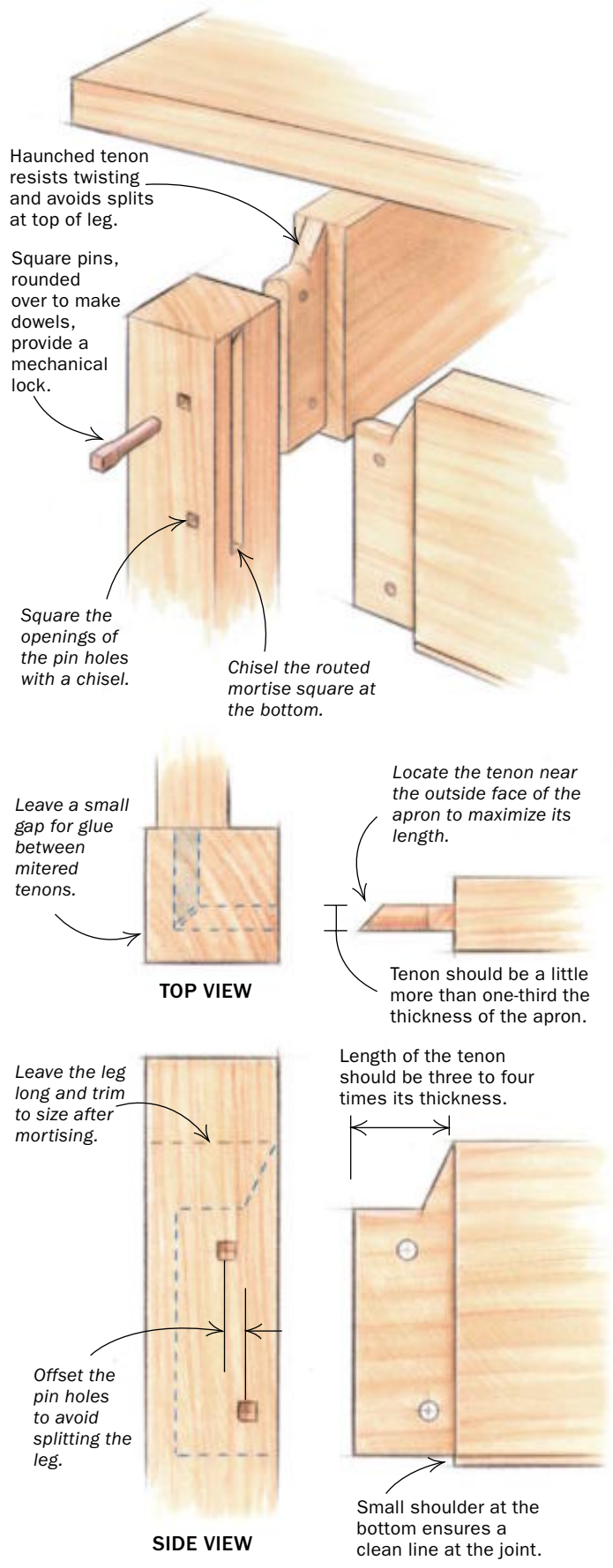

added benefit of covering any bruised edges on the mortise that result from cutting the joint.

Centered tenons are ideal but not always practical—One engineering principle states that the stress on any part is least along the centerline or neutral axis. A centered mortise and tenon is strong because it leaves plenty of wood on both walls (sides) of the mortise and creates substantial shoulders on the tenons. But a centered mortise and tenon does not always work visually.

Deciding on the exact placement is a judgment call that varies with each project. The farther to the outside of the leg you position a mortise, the longer the respective tenon will be. Too far out, though, and the mortise wall will be more vulnerable to splitting under stress. To maximize the tenon length in such situations, I often design the joint so that the tenons meet inside the leg. I have butted tenons together, but doing so makes one tenon shorter than the other. I prefer to miter the tenons within the joint (see drawing, left). This is easy to do, and it can add 15% to 20% more glue surface and length to the tenons.

Haunched tenon stabilizes the top of the joint

A tenon the full height of the apron affords lots of glue surface and strength against bending and twisting forces. But there's a trade-off: A full-height mortise weakens the leg, especially if there are two mortises at the corner of the leg, and serious stress on the apron can more easily split the top of the leg.

A simple solution is to shorten the tenon at the top by $\frac{3}{4}$ in. to 1 in. or so and cut an angled haunch near the top shoulder. This design leaves material at the top of the mortise, which makes for a stronger joint.

I cut the haunch with a dovetail saw and then clean it up with a chisel (see photos, facing page). For speed and accuracy, I mark out the haunch on the tenon using a template. After cutting the mortise for the tenon, I use another angled template to guide the chisel as I cut the haunched area. Because I cut many of my mortises with a router bit, I keep the top of the mortise below the haunch round for a small measure of added strength. Also, a small $\frac{1}{8}$ -in. shoulder at the bottom of the apron tenon will hide any small inaccuracies in cutting the mortise, and it allows for vertical alignment when the table is assembled.

Adjust the fit and use glue sparingly

The best design and the strongest glue won't overcome a joint with carelessly fit shoulders or a sloppy fit between tenon and mortise. Even when I cut these joints with accurate machine setups, I still often find it necessary to improve the fit with a few

WIDE APRONS NEED A BREAK

A mortise longer than 4 in. or so can threaten the structural integrity of a leg. A break in the middle for a haunched tenon alleviates that problem but still keeps the apron from twisting.

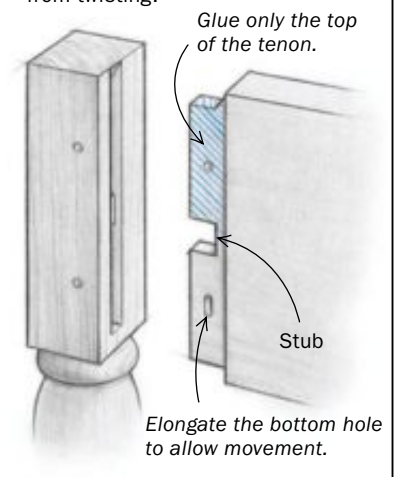

FITTING THE TENON TO THE MORTISE



Tenons on the tablesaw. With the workpiece firmly clamped against this tenoning jig, the tablesaw can cut tenons cleanly and accurately.



Template simplifies layout. Mark out the angled haunch on the tenon using a template.



Handwork is fast and accurate enough. A dovetail saw makes quick work of trimming the angled haunch and mitering the ends of the tenons.

passes of a shoulder plane or a chisel. I want the shoulders to fit tightly over their entire surface and the tenon to slide into place with a minimum of force for a good glue bond.

Part of the long-term strength of the joint is the snugness of the fit, or what I call its mechanical strength. Glue adds strength, but how long does a glue bond last? By its very nature, a mortise-and-tenon joint has wood fibers running cross-grain to one another, which weakens the bond. Flexible modern glues can accommodate some of this movement.

Before gluing, I always dry-fit and clamp the parts together to discover any problems that may arise while there's still time to solve them. To ease assembly, I chamfer the ends of each tenon. Glue-ups can be stressful, but it is worth taking care to place the glue so as to avoid drips and oozing joints that would be a headache to clean up later. With a thin stick about half the width of an ice-cream stick, I apply a light amount of glue into the mortise and on both tenon cheeks. The flat edge of the stick is perfect to squeeze out the glue in a thin, even layer. Another trick that works well is to cut a light chamfer around the mortise to contain any squeeze-out. Ideally, the joint should slip together under light clamping pressure.

For large tables and for peace of mind, I often pin the leg-to-apron joints. I use a hard, straight-grained wood such as rosewood, ebony, or maple for the pins. A contrasting wood can add

a pleasing visual detail, and two small pins are stronger than one large one. Most often, I drill holes for the pins after gluing and drive them in either from the outside or inside of the leg, depending on whether or not I want them to show. □

A woodworking teacher and professional furniture maker, Garrett Hack is a contributing editor to Fine Woodworking.

GLUING AND PINNING THE JOINT



Pins are an insurance policy. Small hardwood pins will hold the joint tightly, even if the glue fails. Hack leaves the outside end of the pin square and holds it with a wrench as he hammers it home.



Attaching Tabletops

Four ways to secure a top to its base

BY MARIO RODRIGUEZ

Attaching a top to its base is a critical aspect of table design and construction. Regardless of the method you choose, it should meet the following criteria: The top must be firmly attached to the base; the top must remain flat; a solid-wood top must be allowed to move seasonally; and the attachment method shouldn't compromise the design of the table or complicate its construction. I'll describe four ways of attaching a tabletop that meet these requirements, along with the reasoning behind each method.

The most important factor to consider when deciding how to attach a tabletop is wood movement. We all know that solid wood

Controlling wood movement

While you cannot prevent a solid-wood tabletop from moving seasonally, you can direct this movement so that it doesn't disrupt the looks or the use of the table. Below are examples of how to secure the tabletop to the frame to control expansion and contraction.

SECURED AT THE CENTER

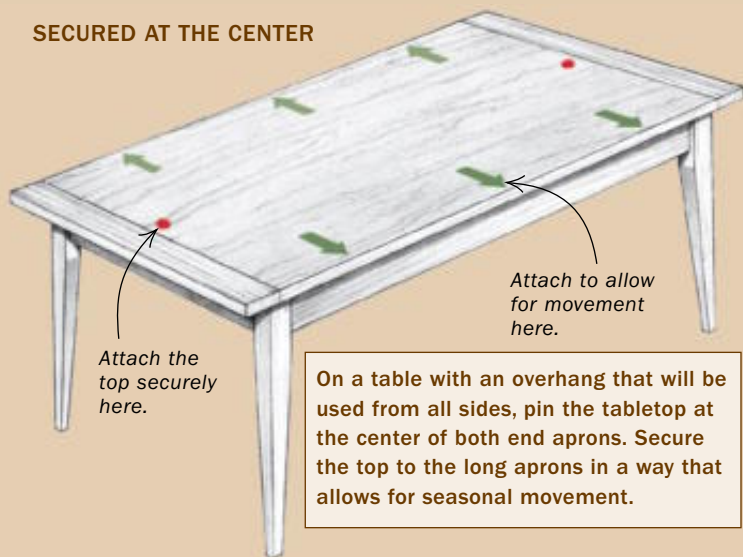

SECURED AT THE BACK



moves seasonally across the grain. It's a fact; you can't do anything to stop it. In the summer, a board will expand across its width because of an increase in humidity. During cold months in a dry, heated room, the same board will shrink and become narrower. If no allowance is made to control or direct this seasonal movement, a tabletop might buckle, or worse, crack and split.

When calculating how much a board will move, I usually allow from $\frac{1}{8}$ in. to $\frac{3}{16}$ in. for every 12 in. of width. Therefore, I would anticipate that a 42-in.-wide tabletop might move about $\frac{1}{2}$ in. overall. This is only a general guide, and certain factors must be taken into account. For instance, in parts of the country with low humidity, wood movement might be minimal.

Another factor is the type of wood you're using: Cherry moves less than white oak but more than mahogany, while flatsawn wood moves more than quartersawn. For more on this subject, read *Understanding Wood* by R. Bruce Hoadley (The Taunton Press, 2000).

Once you accept that the tabletop will move, you can control or direct this movement so that it doesn't disrupt how the table works or looks (see drawings, below). For a freestanding table with a uniform overhang, I anchor the top to the base at the center of the end aprons. That way, any cross-grain movement will occur evenly along each long-grain side. On a demilune (half-round) table, I pin the back edge of the top, which typically is placed against a wall. Conversely, on a writing table I might fix the top along the front of the table so that movement occurs toward the rear.

For this article, I have illustrated four methods of securing a tabletop. The methods are listed by ease of installation, starting with the simplest. The hardware for two of the methods can be purchased relatively cheaply from hardware catalogs, while the rest can be made from shop scrap. This is a low-budget process.

A longtime woodworker and teacher, Mario Rodriguez builds furniture and teaches classes at The Philadelphia Furniture Workshop.

SECURED AT THE FRONT

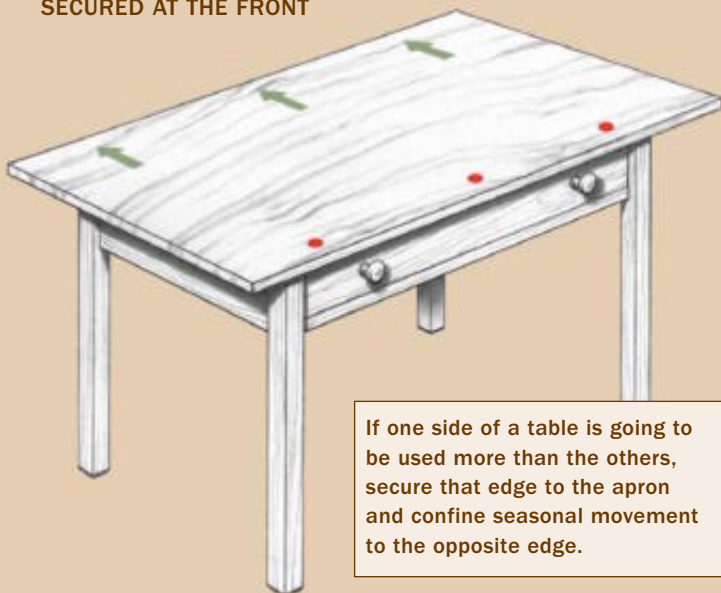

If one side of a table is going to be used more than the others, secure that edge to the apron and confine seasonal movement to the opposite edge.

POCKET HOLES

This is probably the oldest way of attaching a tabletop. Drill a $\frac{1}{2}$ -in. flat-bottomed pocket hole at a 10° angle into the apron. Then drill a smaller pilot hole (to accommodate the shank of a #8 wood screw) into the center of the pocket hole.

Common on antique furniture, pocket holes make no allowance for wood movement, which may explain the number of cracked and split tabletops. On small solid-wood tops (up to 9 in.) or veneered plywood tops, pocket holes can be the only attachment method. On larger pieces, they should be limited to areas needing restricted movement.



Pocket-hole jig. Construct a small jig to hold the apron at approximately 10° while drilling pocket holes with a Forstner bit.



A hole in the pocket. Drill a smaller-diameter pilot hole for the screw that will be driven into the tabletop.

METAL TABLE CLIPS



These clips, also known as S-shaped clips or simply as tabletop fasteners, are probably the easiest and quickest method for attaching tabletops. They fit into a groove or slots cut on the inside face of the apron.

The grooves must be cut before the base is assembled. The

easiest method is to use a tablesaw.

The clips are installed after the base has been assembled. Place one end of the clip into the groove and screw the other end into the underside of the tabletop. Because the groove runs the length of the apron, any number of clips can be used. This method nicely accommodates any cross-grain wood movement whether the clips are parallel or perpendicular to the tabletop's grain: The clips on the end aprons move along the groove as the wood moves, while the clips on the front and back move in and out of the groove.

Another way to install the clips is to cut slots in the apron using a biscuit joiner. This method is quick and easy, and it can be done after the base of the table has been glued up.



Grooves or slots. The clips are installed in grooves cut on the tablesaw or in slots cut with a biscuit joiner.



Secure but free to move. The clips are screwed to the top. With humidity changes, they move side to side and in and out of the groove or slot.

FLAT TWIN-CIRCLE CLIPS

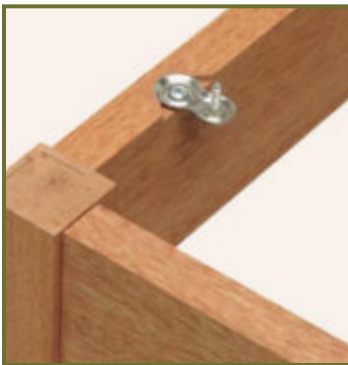

Also known as a desktop or figure-eight clip, this unobtrusive fastener requires only a shallow flat-bottomed recess in the top edge of the apron. The diameter of the recess should accommodate that of the clip, but the recess should be drilled to place the center of the clip past the edge of the apron. This will let the clip pivot slightly, allowing for cross-grain wood movement.

For large tabletops, you can increase the clip's ability to move side to side by chiseling away a little of the apron on both sides of the clip. However, because the clips do not handle wood movement perpendicular to the apron very well, they are best confined to end aprons. Like the metal table clips (above), these fasteners should be relegated to casual, day-to-day furniture pieces.



Precision drilling. The recess should be close to the inside edge of the apron to allow for movement. Use a Forstner bit for clean results.



Attached to the apron. The twin-circle clips can be screwed to the apron either before or after the base has been assembled. Check that the clips are free to move.



Attached to the tabletop. These fasteners are best fitted to either small tables or to the ends of large tables. They do not allow for much wood movement when fitted perpendicular to the grain of the tabletop.

TONGUE-AND-GROOVE BLOCKS

This type of fastener is made from project leftovers. These blocks are attached to the tabletop with screws and have projecting tongues that engage corresponding grooves cut into the apron. The apron grooves are slightly larger than the width of the blocks, allowing for movement and preventing the tabletop from splitting.

By carefully laying out the placement of the blocks and milling properly sized grooves, a more tailored and carefully crafted appearance is achieved. The best way to cut the grooves is with a router guided by a fence bearing on the apron. Properly spaced, tongue-and-groove blocks work very well for all sizes of tabletops.

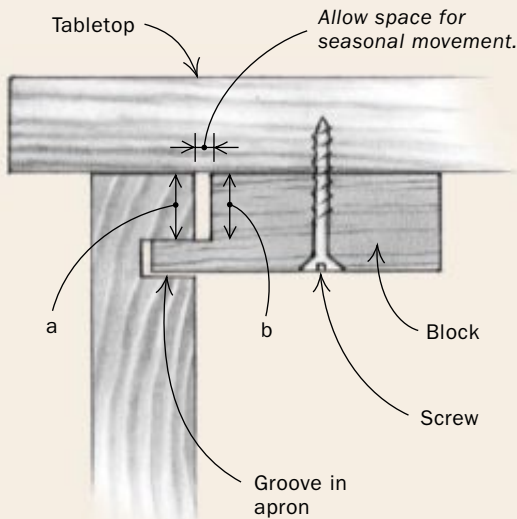
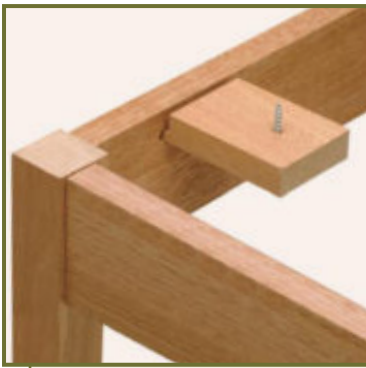

Make sure that the distance (a) is fractionally greater than (b) to ensure that the tabletop is tightly attached to the frame but still free to move.



Two blocks in three cuts. Make a cut about $\frac{3}{8}$ in. deep in each end of a piece of wood. Next, cut perpendicular to the first cut to remove a small block of waste. The push block prevents the waste block from being thrown back when it is cut from the workpiece. Last, cut the piece in half to produce two tongue-and-groove blocks.

Cut the groove. Select a straight bit slightly wider than the tongue of the block and, using a guide fence, rout a series of grooves in the apron.



Attach the blocks. The tongues of the blocks engage with the grooves in the apron. Then the blocks are screwed to the tabletop.



Tables With Drawers

Build tables with one or more drawers
to last for generations

BY WILL NEPTUNE



Many tables, one approach. Neptune's students have used his drawer system successfully in high-end tables (above), but the approach works equally well for simpler tables.

THE ESSENTIAL TABLE WITH DRAWER

This demonstration table is designed to show that no matter the style, a table with a single drawer has the same interior components. The aprons, kickers, doublers, and runners all combine to guide the drawer in and out of the drawer opening (called the pocket).

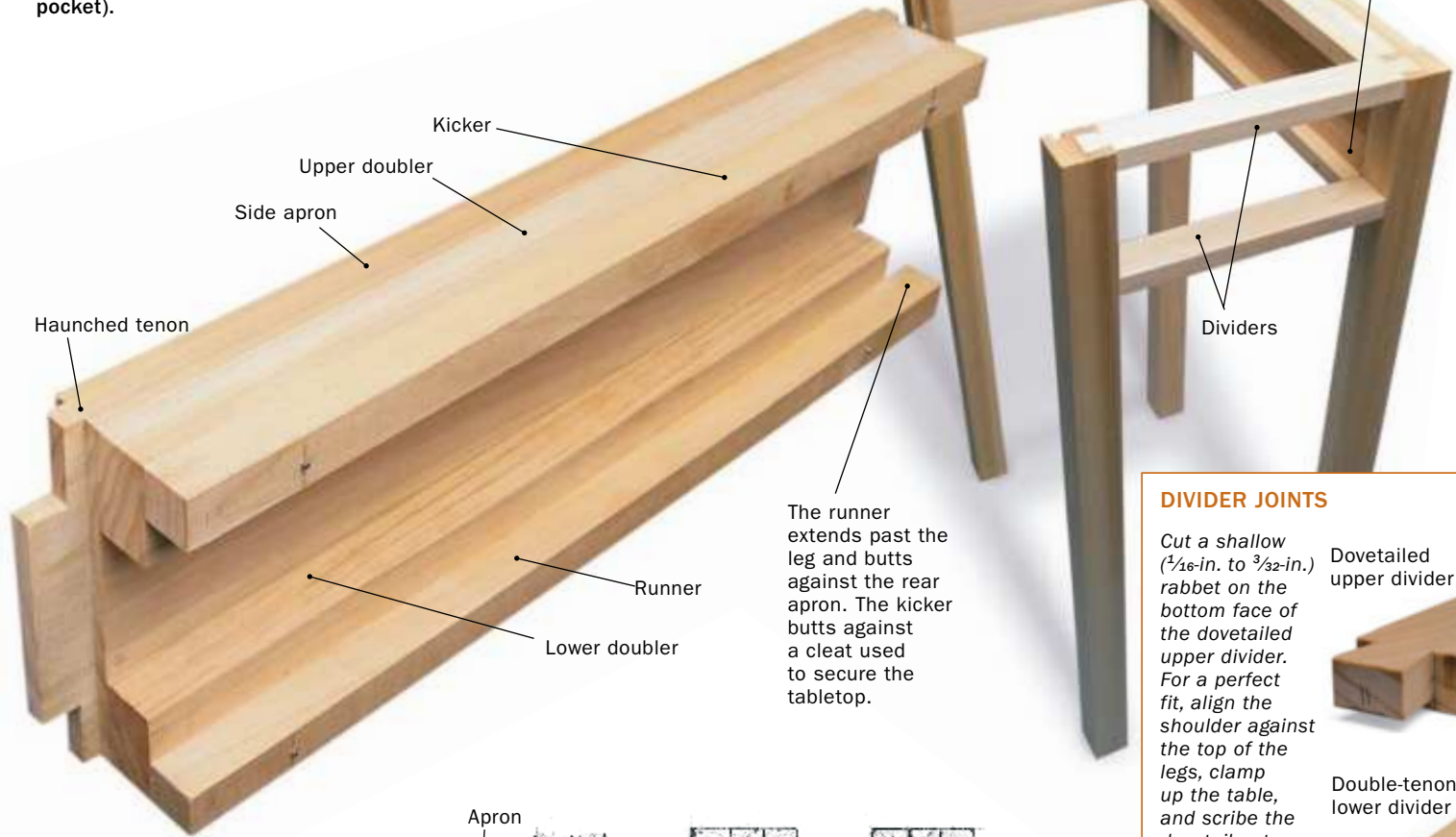

The runner extends past the leg and butts against the rear apron. The kicker butts against a cleat used to secure the tabletop.

DIVIDER JOINTS

Cut a shallow ($\frac{1}{16}$ -in. to $\frac{3}{32}$ -in.) rabbet on the bottom face of the dovetailed upper divider. For a perfect fit, align the shoulder against the top of the legs, clamp up the table, and scribe the dovetail onto the leg. The shoulder on the double-tenoned lower divider is optional.

Dovetailed upper divider

Double-tenoned lower divider



SIDE APRON SYSTEM

1. Doublers are glued to the inside face of the side apron.
2. Square-dimensioned runners and kickers are glued and nailed to the doublers.
3. The runners and kickers house the drawer while the doublers guide the drawer side in and out of its opening.

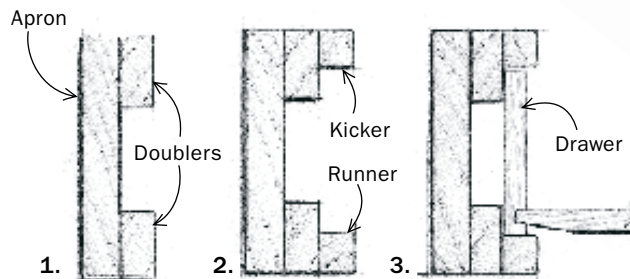

I like to tell my woodworking students that there's a Shaker nightstand hidden in every table with drawers. I may be overstating my case, but only by a bit. At North Bennet Street School, we teach strategy. Our largely traditional approach to building tables with drawers isn't the only approach, but it's almost endlessly adaptable; once you understand it, you can apply it to Chippendale writing desks, Pembroke tables, contemporary tables, whatever you like. A single, sound approach is liberating: It leaves room for good design and good workmanship while eliminating the need for mock-ups, prototypes, and reinventing the wheel.

There's nothing new about this attitude. Thomas Chippendale's *Chippendale Director* contains page after page of chairs and chair backs. No joints. No dimensions. Nothing about how to build a

Chippendale chair. Chippendale assumes his readers know how to build a chair and that chairs are all built the same way.

When our students build a table with drawers, they learn a system. I recall a student who started a veneered Pembroke table after having made a simpler table. "Remember when you built the Shaker nightstand?" I said to him. "Now here's what you're gonna do different." His eyes lit up and he said, "Ah, and you just make this longer, and curve that and, oh, yeah, yeah, yeah." He knew how to build a Pembroke table—he just didn't realize it.

The single-drawer demonstration table I built (above and facing page) reveals the basic components of a simple table-with-drawer system: dividers, which replace the front apron to make room for the drawer; doublers, which fill out the side aprons and serve as drawer guides; runners, which support the weight of the drawer;

REVEALED: A TABLE WITH MULTIPLE DRAWERS

A long table with multiple drawers has the same basic components as a narrower table with a single drawer, but partitions are added between drawers. For illustrative purposes, this table shows two types of partitions.



UPPER DIVIDER JOINED WITH TWO DOVETAILS

A wide upper divider is dovetailed to the doubler as well as to the leg. If the inside dovetail is too close to the leg, the short-grained end of the doubler can easily crack off.

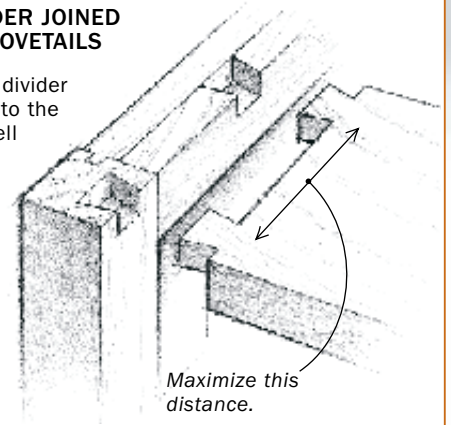

and kickers, which keep the drawer from tipping when pulled out. Some tables require ledgers to support the runners and kickers, and there are others that do without doublers. Nevertheless, if you took apart a Pembroke table, you'd find the basic components in one fashion or another. And you'd know the secret to building tables with drawers: Inside, they're all about the same.

A strategy for construction as well as design

It's worth taking a close look at the components that make up the table-with-drawer system, not only in terms of how each functions as part of an overall design but also in terms of how each is constructed in concert with the other components.

Although there's no reason why you couldn't apply my strategy to building a table by hand, I'm going to assume you will use a tablesaw and a thickness planer. For me, efficiency demands the

use of machines, even for the construction of traditional furniture forms. The key to efficient construction lies in designing joints that share like dimensions and like locations relative to the leg. The tablesaw cuts related parts to equal length; the planer establishes consistent thicknesses and widths. Together, the tablesaw and thickness planer allow groups of parts to have compatible machine-cut joints. When you plane the dividers to thickness, you also can plane a number of square-dimensioned sticks for runners, kickers, and ledgers. If you make the haunched tenons on the aprons and the double tenons on the lower divider the same length and location from the face of the leg, then you can cut all the mortises on a hollow-chisel mortiser with a single fence setting. And you can cut the main shoulders of these joints, as well as the dovetails on the upper divider, without changing the dado height or the fence setting.

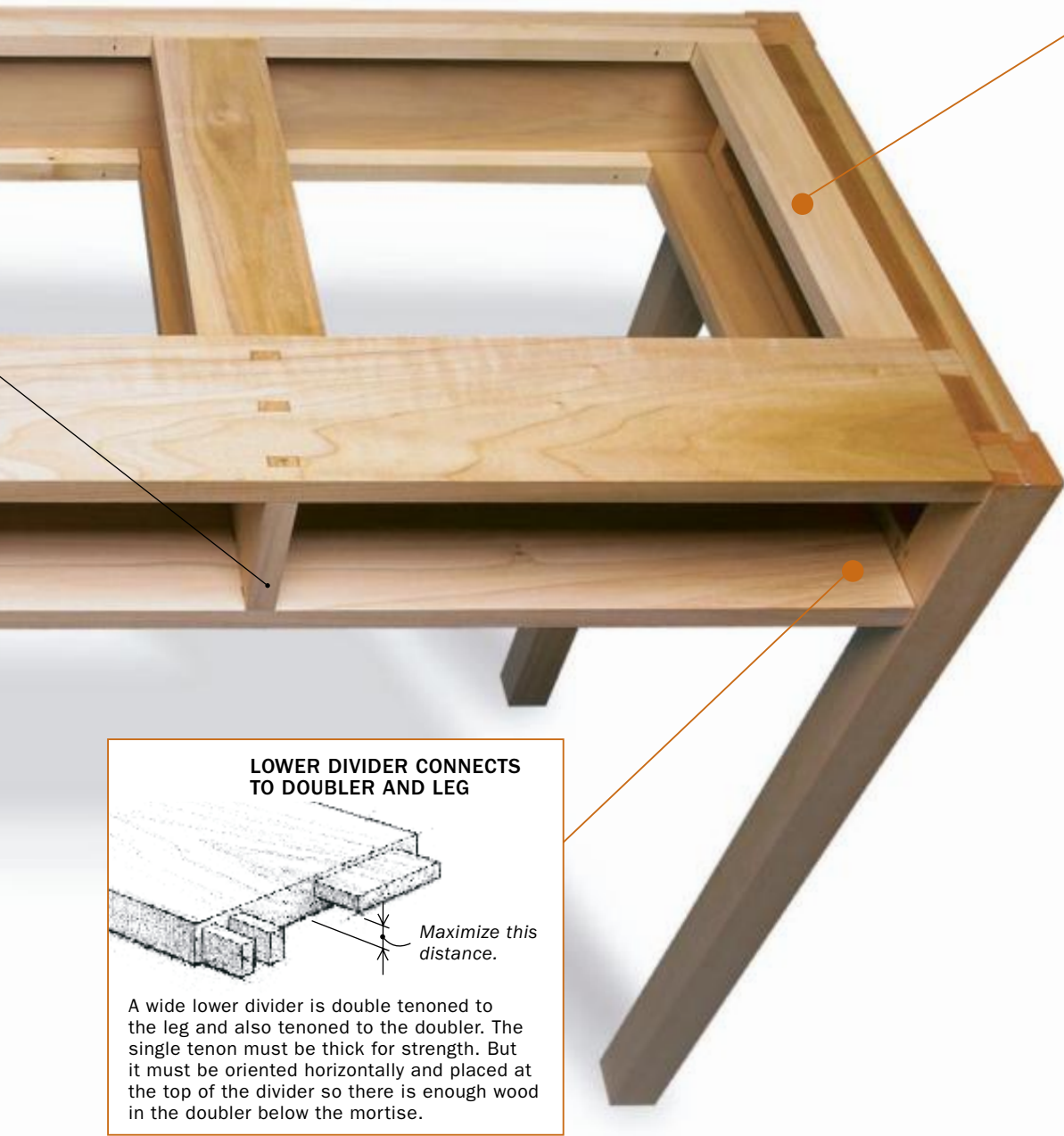

KICKER AND RUNNER



Tenoned at the front

At the front, where strength is needed, the kicker and runner are tenoned to the dividers.

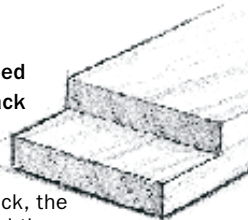

Half-lapped at the back

At the back, the kicker and the runner are half-lapped to the ledger. The runner should be half-lapped on top so that it rests on the ledger supporting the drawer. The kicker should be half-lapped on the bottom, because the drawer, if tipped, will push against the kicker from below.

Snapped into place

Kickers and runners can be installed after the table frame has been glued up.

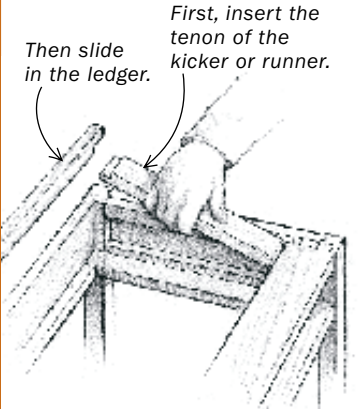

First, insert the tenon of the kicker or runner.
Then slide in the ledger.

LOWER DIVIDER CONNECTS TO DOUBLER AND LEG

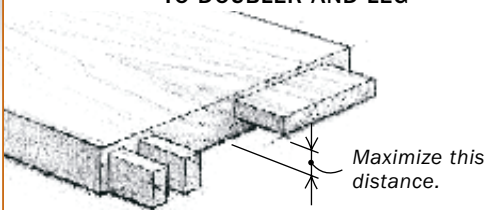

Maximize this distance.

A wide lower divider is double tenoned to the leg and also tenoned to the doubler. The single tenon must be thick for strength. But it must be oriented horizontally and placed at the top of the divider so there is enough wood in the doubler below the mortise.

Once you've milled the pieces, you're ready to put together the essential table: four legs, three aprons, and two dividers. The upper divider is dovetailed into the leg; the lower divider can't be dovetailed, so it's double tenoned (see drawing, above). With the table glued up, you can take your time installing the inner pieces—doubblers, kickers, runners, and (if need be) ledgers.

The first pieces to go inside I call doubblers because, roughly speaking, they double the thickness of the aprons. More important, the doubblers bring the apron assembly flush to the inside face of the leg, so you don't have to notch the runners and kickers. Some people would call the doubblers side guides, and that's what they are as far as the drawer is concerned: blocks that keep the drawer from shifting from side to side as it's pulled out. Cut four doubblers to length, and glue them to the top and bottom of the side aprons.

Onto the surface of each doubler, glue one of the little square sticks you thickness planed at the same time as the dividers, one at the top of each upper doubler to serve as a kicker, and one at the bottom of each lower doubler to serve as a runner. Together, a doubler and runner/kicker form an L-shaped piece, which you could make by rabbeting one piece. But they're much easier to make and install as two pieces. The wide face of the doubblers remains stable when glued flush against the apron. The kickers and runners are such small squares that they won't curl or twist.

What to do when the span gets long

On a small table like my single-drawer demonstration table, gluing the runners and kickers to the doubblers, and letting them butt against the dividers and the rear apron (or a ledger for securing the tabletop), provides enough strength to support the drawer. On a



larger or heftier table or one with multiple drawers, you may need to join the runners and kickers at the front and back. At the front, you can tenon the runners to the lower divider and the kickers to the upper divider.

You may not want to tenon the runners and kickers at the back, however, because you'd have to glue up all the pieces at once. Imagine doing that on a lowboy with five offset drawers.

To avoid having to glue up all those pieces at once, dado the top and bottom ledgers (which you have milled and ready) across their width to accept a half-lap joint from each runner and kicker, and then temporarily attach the ledgers to the rear apron using brads. To allow you to install the kickers and runners after the table frame is glued up, cut them a touch short. Cut the tenons relatively short as well. Even a $\frac{3}{8}$ -in. tenon will take the weight of a drawer. Just slide in the tenons, and snap the pieces into place. Then slide in the ledgers, using the brads to locate them for gluing.

If the span of the table is long and you need stronger dividers, there are only two things you can do: Make the dividers wider, or make them thicker. Making them thicker is, by far, the easiest route to take because a little thickness adds a lot of strength. But many designs simply won't allow for a thick divider.

If you settle on making wide dividers, however, you'd better make them really wide. An extra $\frac{1}{2}$ in. isn't going to increase the stiffness of the divider to speak of, and an undersize divider will deflect downward. I'd make the divider 4 in. wide at least; a 4-in. divider is no more work than a narrower one. The trouble is, a wide divider stands a good chance of cupping or twisting. To resist racking, you have to join a wide divider not only to the legs but also to either the doublers or the side aprons.

When you join a divider to a side apron or doubler, however, you run the risk that the movement of the apron as it expands and contracts will work the divider like a lever. To prevent this movement from cracking the dividers (below), keep the aprons relatively narrow (ideally less than 4 in. wide), and make the dividers really wide so that movement at the inner dovetail is spread over a greater distance before it reaches the front dovetail.

Joining the dividers directly to the side aprons is historically accurate, but it's tricky because you have to mill dividers longer than the rear apron and then notch the dividers around the leg. The other way to join

wide dividers is to attach them to the doublers. A big advantage to attaching wide dividers to the doublers rather than to the aprons is that you can make both dividers the same length as the rear apron. The dovetails are easy to cut because they share a shoulder, and all these shoulders can be cut with the same dado setup used for the apron tenons. The forward dovetail is joined to the leg exactly as it would be on a narrow divider. The inner dovetail can be either a full dove-

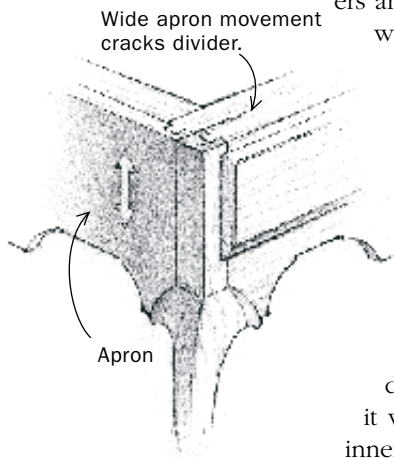

TWO PARTITION OPTIONS

DOVETAILED PARTITION

A dovetailed partition is easier to install than a tenoned partition because it can be slipped into place after the dividers have been assembled.

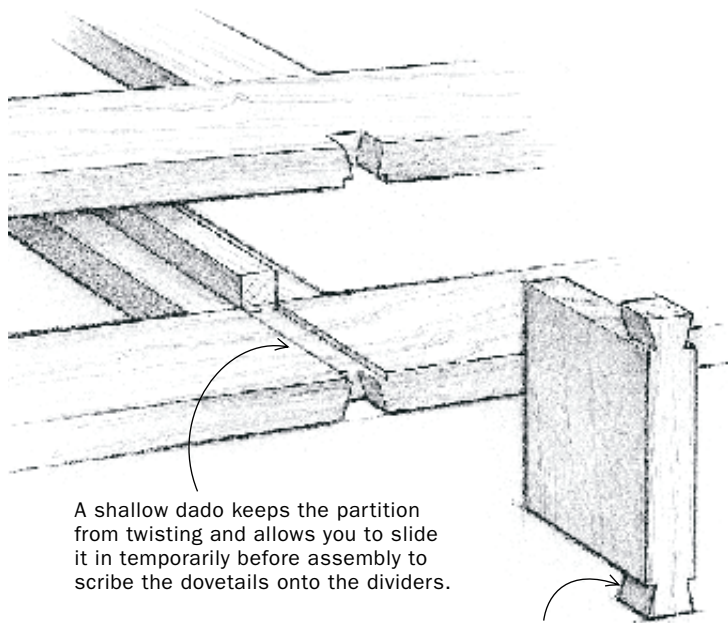

A shallow dado keeps the partition from twisting and allows you to slide it in temporarily before assembly to scribe the dovetails onto the dividers.

A partial, or stopped, dovetail doesn't compromise the strength of the divider.

tail, as it is in my table, or a half-dovetail. In either case, leave as much space as possible between the inner dovetail and the end of the doubler. If the housing for the dovetail is close to the end of the doubler, the little short-grained piece that remains can easily crack off.

Joining the lower divider to the lower doubler is a little trickier. The lower divider, you remember, is double-tenoned into the leg, so you don't want to dovetail it to the lower doubler because then assembly would be difficult. Instead, join the lower divider to the lower doubler with a horizontal tenon, cut to the same length as the twin tenons. This inner tenon must be as thick as possible for strength, with little or no shoulder on top, so there is enough



TENONED PARTITION

The strongest way to tie together the dividers between the drawers is a vertical partition with through double tenons or triple tenons. (The plan view drawing below is shown at the lower divider.)

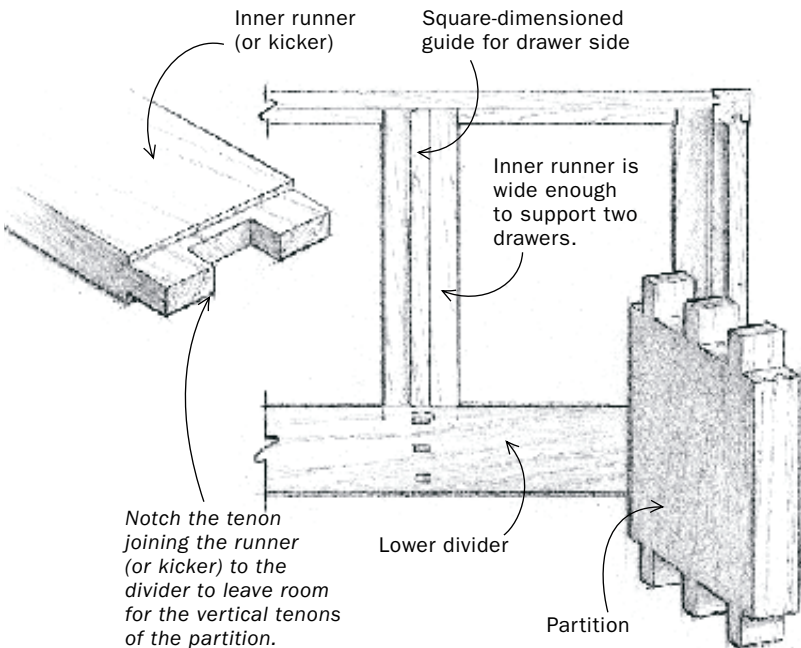

wood in the doubler below the mortise to provide adequate strength; the doubler will still have plenty of wood above the mortise (see bottom left drawing, p. 45).

Whether you make the dividers wider or thicker, sizing them is a judgment call. Err on the side of overbuilt. If the table bounces, what are you going to do about it? If it's a bit sturdier than it needs to be, you'll never know, and you'll be none the worse for it.

How to handle more than one drawer

A table with multiple drawers requires a partition tying together the dividers between each drawer and a complement of internal runners, kickers, and drawer guides. It makes sense to mill the

partitions at the same time as the dividers; just be sure to leave the divider blanks long, and whack the ends off. There are your partitions, already at the proper width.

If you feel comfortable with the span of the dividers and you simply want two drawers for looks or functionality, then you can stop-dado a nonstructural partition into the dividers from behind. But if the dividers are really long—for example, 3 ft. or 4 ft.—the stopped-dadoed partition may pop out when the table deflects downward.

The easiest way to strengthen the joint between the partition and the divider is to use the same double-tenon arrangement used to join the lower divider to the legs. On my multidrawer demonstration table, the dividers are so wide, I used triple tenons (see photo and drawing, left), but the idea is the same. I usually run the tenons through the dividers and sometimes even wedge them. If you join a pair of 3-ft. dividers together with two partitions and join the whole assembly to the legs, then you've created a girder. It's amazing how stiff this system is.

So now that you have partitions between the dividers, how do you support the drawers in the middle of the table? You mill runners and kickers wide enough to support drawers on both sides of the partitions, tenon them to the dividers, and half-lap them to the ledger on the rear apron.

Treat these inner runners and kickers as you would the runners and kickers next to the doublers, with one big exception. You have to notch the middle of the tenons so they don't interfere with the vertical twin tenons of the partition. To keep the drawers from swimming around, take another square stick, and glue it onto the center of the runner, long grain to long grain, to serve as a drawer-side guide. Problem solved.

You could also dovetail the partition to the dividers. A dovetailed housing cut across the full width of the dividers could remove so much material that it would compromise the strength of the dividers, so use a stopped dovetail in the front to tie the dividers together, plus a shallow 1/8-in. dado across the width of the dividers to keep the partition from twisting (see drawing, facing page).

Dovetailed partitions are easier to install than tenoned partitions because with dovetailed partitions, you can attach both dividers to the legs and then simply slip the partitions into place. The shallow dado allows you to slip the partition into the dividers and then scribe the tail onto the dividers before cutting its housing. It's possible to cut the dado narrower than the dovetail to hide it from the front, but now I'm getting into variations on variations.

The beauty of this approach to engineering a table with drawers is that it doesn't rely on the proportions or the style of the table. You can cut big legs or little legs; you can set the aprons flush to the legs or inset them; you can turn the legs or taper them; you can make the table long and low and turn it into a coffee table or tall and long and call it a writing desk.

What I hope I've constructed here is a conceptual framework onto which you can overlay your own design ideas. □



Will Neptune is a furniture maker in Acton, Mass., and a former woodworking instructor at North Bennet Street School in Boston.

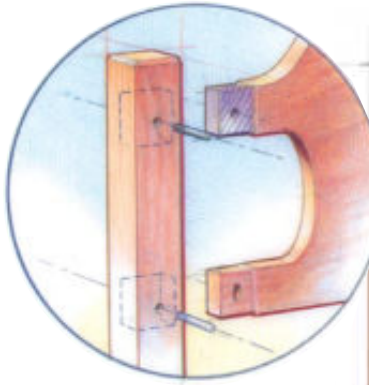

HEADBOARD

Headboards vary in design and can be made from a single, solid board or be of frame-and-panel or post-and-rail construction.

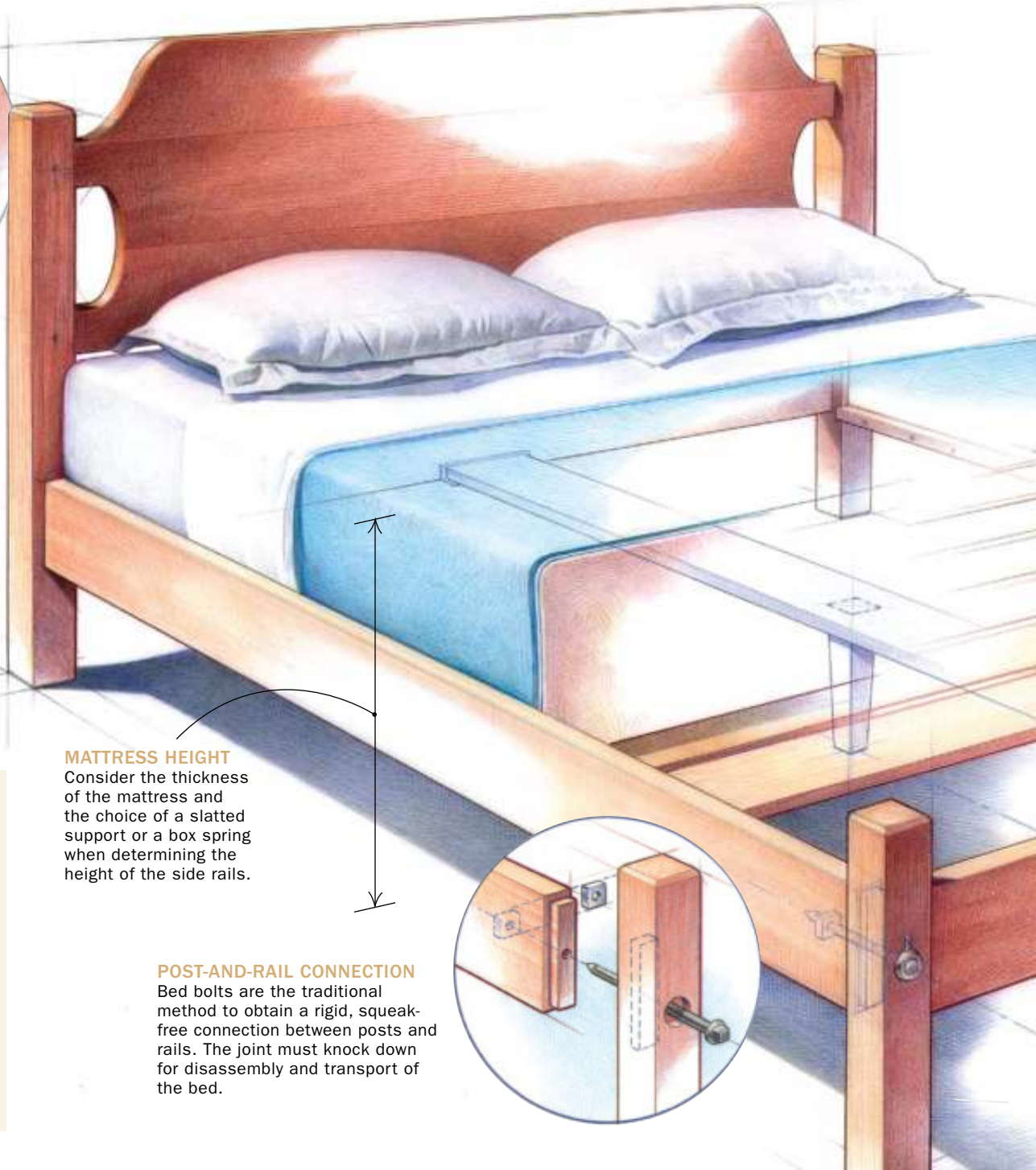

MATTRESS HEIGHT

Consider the thickness of the mattress and the choice of a slatted support or a box spring when determining the height of the side rails.

STANDARD MATTRESS SIZES

TWIN

39 in. by 75 in.

FULL (OR DOUBLE)

54 in. by 75 in.

QUEEN

60 in. by 80 in.

KING

76 in. by 80 in.

CALIFORNIA KING

72 in. by 84 in.

POST-AND-RAIL CONNECTION

Bed bolts are the traditional method to obtain a rigid, squeak-free connection between posts and rails. The joint must knock down for disassembly and transport of the bed.



SHAKER



ARTS AND CRAFTS



SLEIGH

Anatomy of a Bed

Construction details that work
with almost any design

BY JEFF MILLER

MATTRESS SUPPORT

Although conventional wisdom says a box spring prolongs the life of a mattress and adds support, most manufacturers concede that a well-designed slatted support is an acceptable substitute.

Bed designs may vary widely, but sound construction is a critical part of any design's success. Fortunately, there aren't too many structural issues to deal with. First, you have to figure out the best way to support the mattress and box spring. Also, because most beds need to be transportable, they must come apart quickly and easily, and when put back together be rigid and silent. That means you must choose the best systems for joining the rails to the posts and the posts to the headboard. I've built countless beds during my woodworking career. Using the techniques I've learned, you can make any style of bed.

Beds come in a variety of standard sizes, but these standards are not absolutes. If your mattress is larger than standard, you'll have to adjust the frame size; if it is smaller, you should size the frame for a standard mattress so when the time comes to replace it, a new mattress will fit. In general, plan to leave $\frac{1}{4}$ in. to $\frac{1}{2}$ in. of space on the sides to allow room for the bedding. I sometimes leave a little more room at the end, with a footboard that rises above the mattress, so there is some space to hang your toes off the end of the bed or to make room for the cord of an electric blanket.

*Jeff Miller is a furniture maker in Chicago and the author of *Beds* (The Taunton Press, 1999).*

FOOTBOARD

A foot rail (shown here) is one option, while a true footboard is a smaller version of the headboard (see the Arts and Crafts and sleigh beds below).

King-size beds require a center rail supported by an angle iron at each end and a leg in the center.

DESIGN DETERMINES JOINERY

Many styles of beds are united by similar post-and-rail construction. By changing a few details, you can change the look of a bed to suit your taste. Shaker beds typically feature slab headboards and foot rails. Arts and Crafts beds have both a headboard and footboard made of slats or square spindles. Sleigh beds introduce a curve to their frame-and-panel construction. To keep the lines clean, most designs use concealed hardware. Because of their height, four-poster beds must disassemble completely. All four rails are connected by bed bolts, and the headboard floats in mortises in the posts.

FOUR-POSTER

CONSTRUCT THE HEADBOARD

SOLID HEADBOARDS NEED ROOM TO MOVE

HEADBOARD WITH TWO TENONS
Construction must allow for seasonal movement of the headboard.

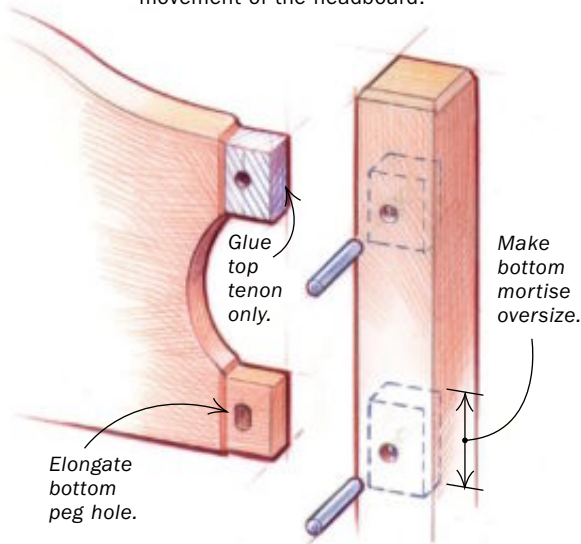

HEADBOARD WITH ONE TENON
Use a wide, short tenon for strength in conjunction with a long stub tenon for rigidity.

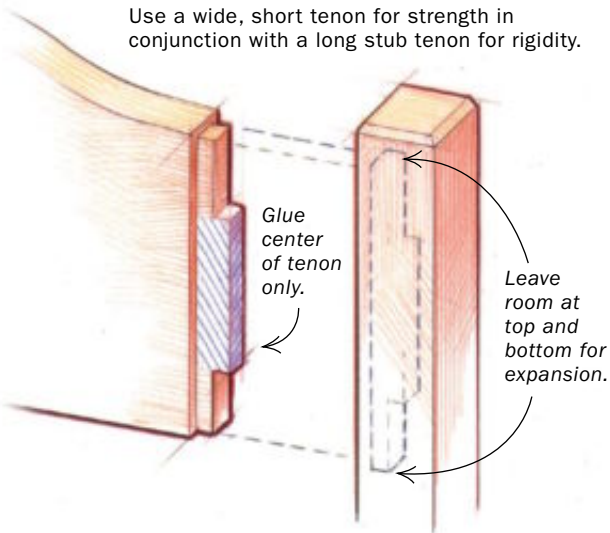

FLOATING HEADBOARD
Use this method to allow the entire bed to be disassembled, if necessary. Tenons are shouldered only at the back, so no gaps are visible when the headboard moves.

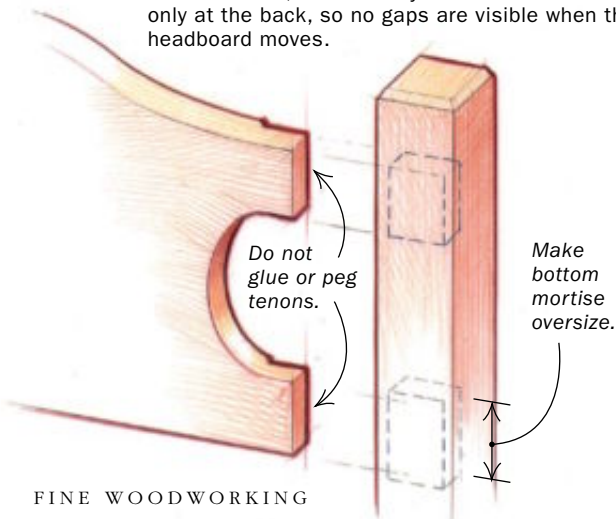

The headboard (and footboard, if any) assembly usually is built as a unit, with mortise-and-tenon joints connecting the rail to the two posts. The mortise and tenon provide the maximum strength to this connection, but the details of the joint vary based on the bed's design. On a wide plank headboard, you must allow for wood movement. With two separate tenons, glue only the upper one, or use a wide, short tenon floating in a long, shallow mortise, anchored in the center with a full-depth tenon that is glued.

On a four-poster bed, the headboard plank simply floats (without glue) in deep, slightly oversize mortises. The headboard then can be removed when the bed needs to be disassembled.

A headboard that has slats, spindles, or a frame-and-panel design will have a crest rail tenoned into the tops of the posts. Be sure to offset the mortise-and-tenon joint toward the bottom of the crest rail so that you leave as much wood as possible at the end of the post, above the joint.

SLATS OR PANELS REQUIRE POST-AND-RAIL CONSTRUCTION

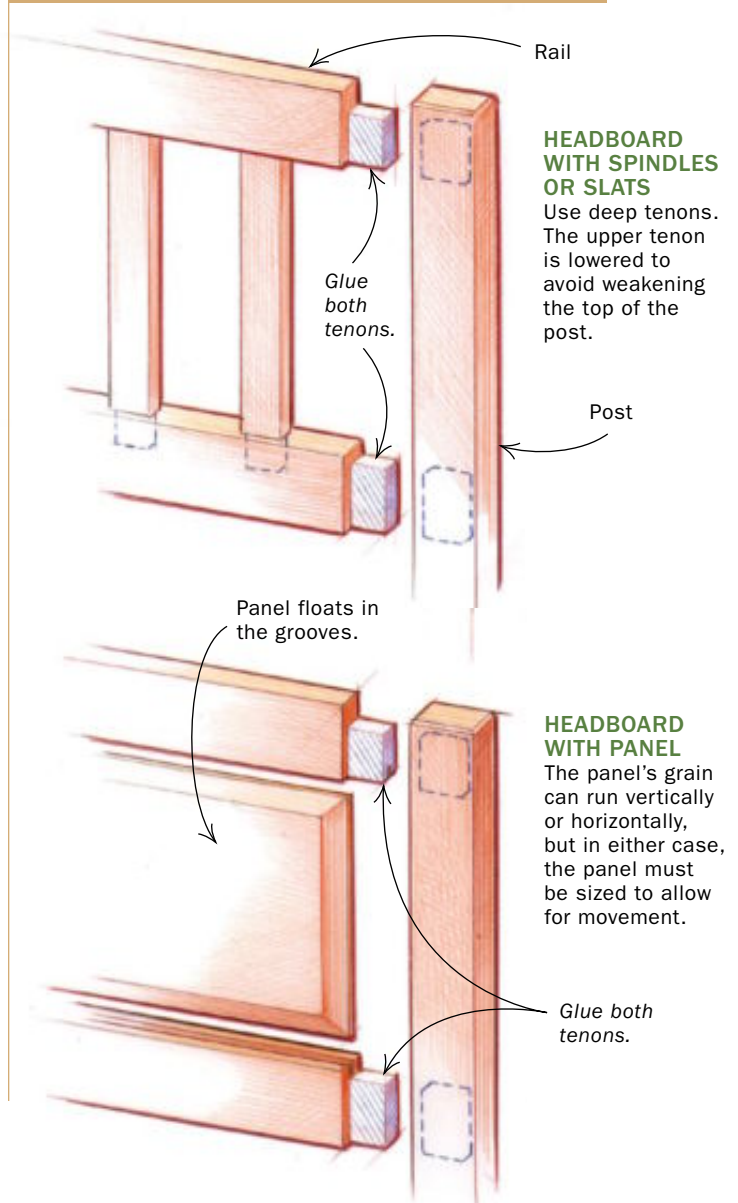

SUPPORT THE MATTRESS

BOX SPRINGS NEED EDGE SUPPORT ONLY

About 80% of the mattresses sold in the United States come with a box spring. Full- and queen-size box springs need support around the edges in the form of wooden cleats, angle iron, cast-iron hangers, or aluminum extrusions. All of these supports are screwed to (and sometimes recessed into) the side rails. King-size box springs come in two halves for portability and need an additional support down the center of the bed that's wide enough to support both halves, with a leg in the middle of this support.

The side rails are typically 5 in. to 8 in. wide and 1 in. to 1½ in. thick. The combined width and thickness should be enough to prevent the rail from sagging under load. I usually use 6-in.- or 7-in.-wide rails with a box spring; but to hide the box spring completely, the rails must be close to 8 in. wide. This choice is strictly a design decision.

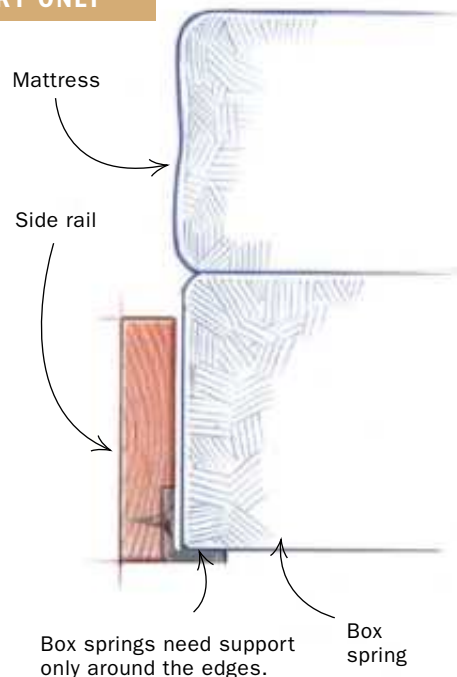

WOODEN CLEATS

An economical choice, wooden cleats are glued and screwed to the rails.

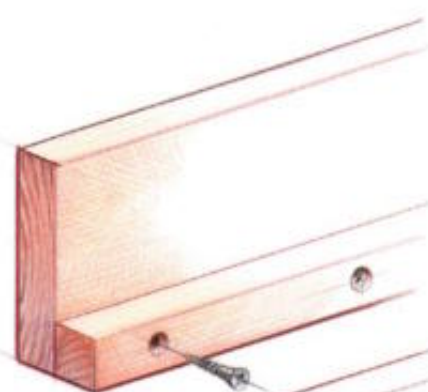

ANGLE IRON

Angle iron can be purchased or recycled from old bed frames. Run a rabbet in each rail, then screw the angle iron in place.

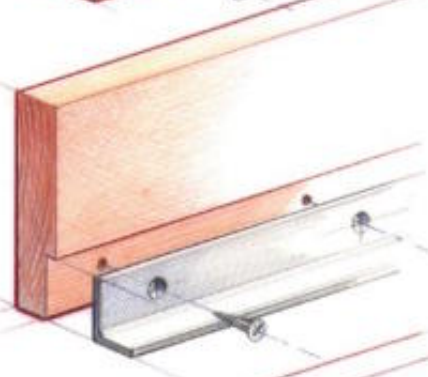

CAST-IRON HANGERS

Because of their length, cast-iron hangers support a greater range of box-spring widths. They can be mounted slightly below the rail to lower the mattress height.

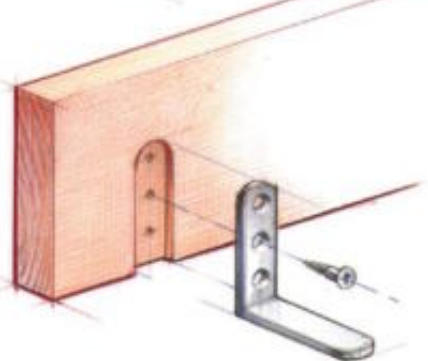

FOR A LOW PROFILE, USE SLATS INSTEAD OF A BOX SPRING

In Europe, 80% of mattresses are designed to be used without a box spring and to be supported by wooden slats. I find the slatted support a little firmer, but the choice is up to you.

I use ¾-in.-thick by 4-in.-wide slats, which are thicker and wider than commercially available ones. Spaced 1 in. apart, the slats provide some flex for comfort and also allow air to circulate around the mattress or futon. Soft maple or poplar makes good slats, but avoid softwoods, which are too flexible.

The slats usually rest on wooden cleats. To keep the slats from shifting, I notch the ends, fitting each slat over a dowel that protrudes from the cleat. On a king-size bed, I add a strut down the center from headboard to footboard, with a leg in the middle.

Some mattresses are designed to be used with solid platforms, made of plywood with support underneath to prevent sagging. However, because these platforms do not have built-in flexibility or give, they should not be used with regular mattresses.

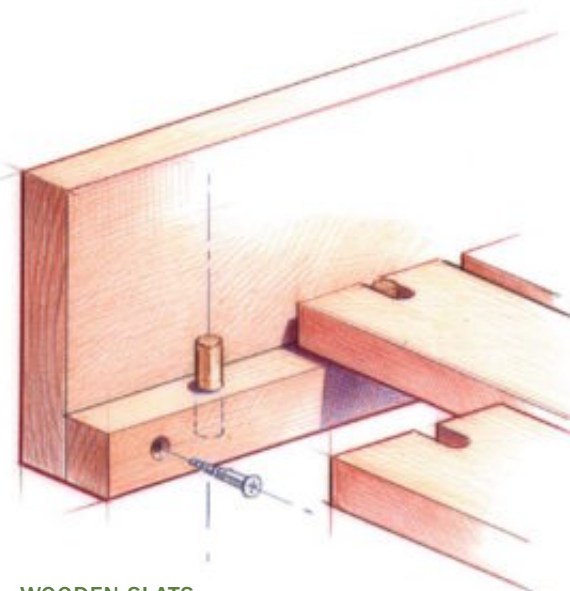
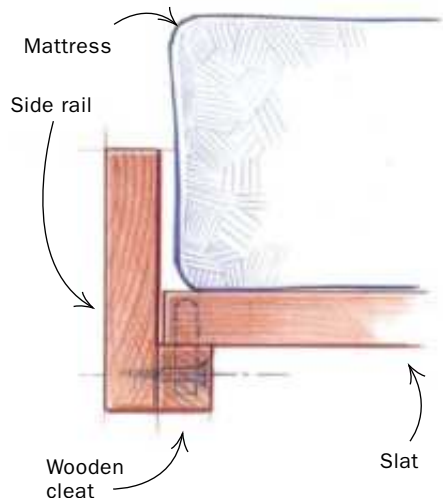

WOODEN SLATS

Slats combine the right amount of support and give for a mattress. To prevent the slats from shifting, notch them to fit around dowels fixed to the cleats.

THREE SOLID POST-AND-RAIL JOINTS

Because the side rails support the mattress, the joints between the side rails and the bedposts are important to the overall solidity of the bed. Yet they need to be disassembled easily. This is an interesting challenge, considering that wood expands and con-

tracts with humidity changes. Wood also can compress, either as a result of seasonal changes operating against a metal fastener, or due to the stresses placed on the bed in use. There are a wide variety of fasteners available that attempt to meet this challenge.

BED BOLTS ARE TRADITIONAL

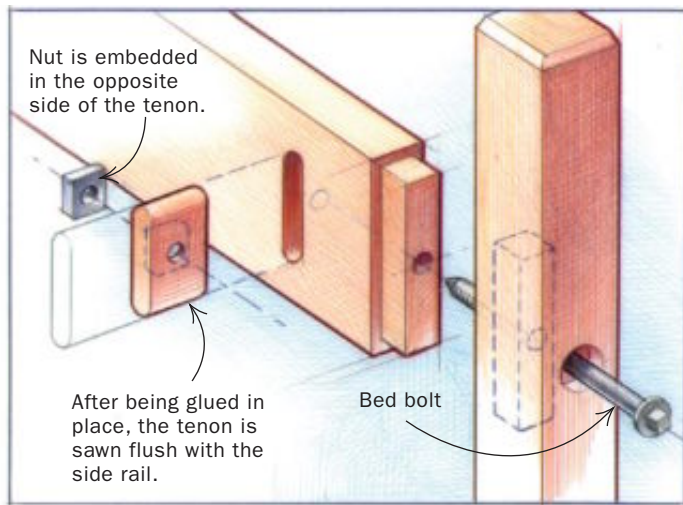

Traditional bed bolts are forged to have a square-drive head that flares out, creating a broad bearing surface on the wood. Regular bolts employ a washer for the same effect. To install both types of bolt, drill a counterbored hole through the bedpost and into the rail, where it meets either a nut embedded in the rail (for the traditional bed bolt) or a nut and washer in a recess. The bolt alone is not enough to hold the rail securely and to prevent rotation, so either a shallow mortise and tenon or a pair of dowels is needed to complete the glueless joint.

A modern approach is to use bolts and washers with barrel nuts. This approach does not require a special wrench. Alignment of the drilled holes, however, is critical, and barrel nuts that are large enough to use with 5/16-in. or 3/8-in. bolts often require 1½-in.-thick rails. There are many approaches to dealing with the bolt hole in the post: The simplest is to treat it as part of a quality joint and to leave it exposed. More

likely, you'll want to conceal it, either with a brass cover screwed to the bedpost above the bolt hole or with a simple mushroom-shaped wooden plug, although the latter tends to work its way loose.

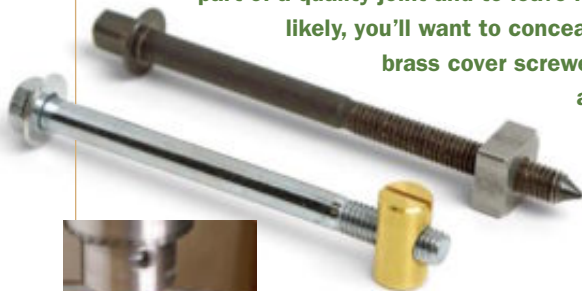

A new bed bolt. Traditional bed bolts (rear) have stood the test of time, but newer bolts with barrel nuts (front) are easier to install. Simply drill a hole on the inside face of the rail and drop in the barrel nut.

INSTALLING BED BOLTS



Drill the bolt hole. After drilling through the post into the tenon, remove the post and complete the hole to its full depth.



A recess for the nut. Use a plunge router and a straight bit to cut a mortise on the inside of the rail.

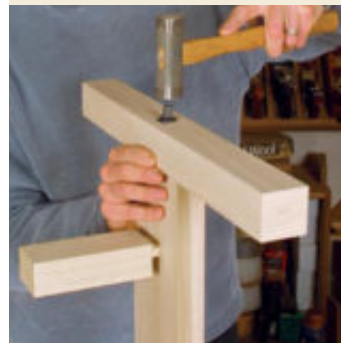

Locate the nut. Fit a tenon into the mortise, insert the bolt, and give it a sharp tap to leave an indentation (left). Drill a hole at the mark and inset the nut into the tenon. Glue the tenon into the rail with the nut facing away from the post (right), and trim it flush.



One tight joint. After cutting the tenon flush with the rail, insert the bolt through the post and crank it tight with the bed-bolt wrench.

HIDE BED BOLTS FOR A CLEAN LOOK

You also can bolt a bed together from the inside of the rail, leaving no holes or hardware visible on the outside. This involves embedding the nut in the tenon of the headboard or footboard rail, then routing a specially shaped recess on the inside of the side rail. A jig is helpful for routing the recess in the rail.

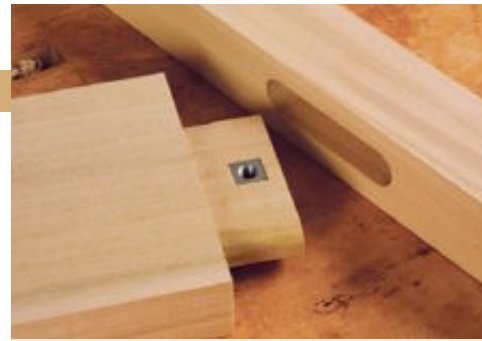
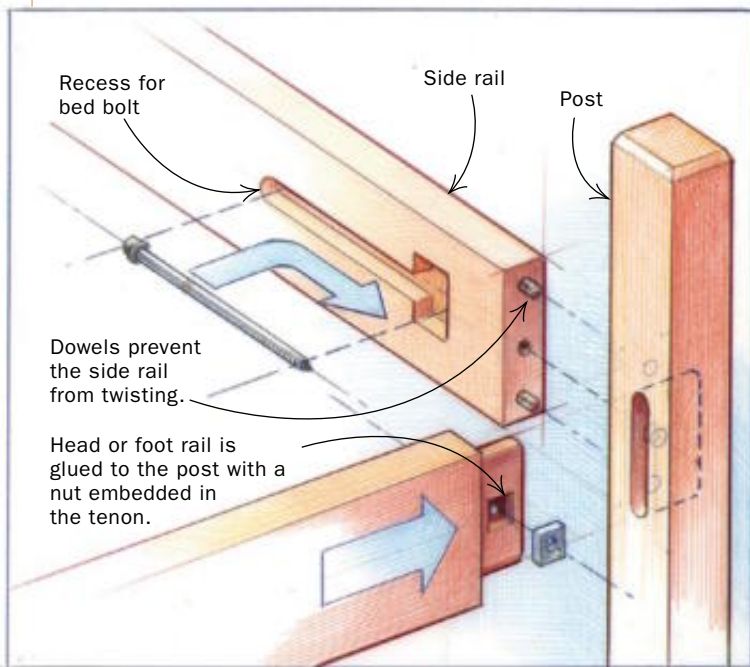

INSTALLING HIDDEN BED BOLTS

Hidden nut. The nut is inset into the tenons on the head or foot rail and faces away from the side rails.



Hidden bolt. Use a jig to rout a T-shaped slot inside the side rails (above). Then insert the bolt and tighten it into the nut embedded in the head or foot rail (right).



BRACKETS ARE FAST AND INVISIBLE

There are many types of two-part fasteners for attaching the side rails to the posts. Look for the most solidly made hardware. Because screws driven into end grain don't have a lot of holding power, you should glue wood dowels into the rails to provide some long grain for the screws to pass through. Use the largest screws possible when attaching all parts of the hardware. If the fasteners loosen up, it is hard to fix the problem. For all these reasons, my preference is to use fasteners only on occasionally used beds.

INSTALLING BED-RAIL BRACKETS



Install the clip plate. Glue hardwood dowels into the inside of the side rail to give the screws something to bite into besides end grain.



Make room for the clips. The strike plate is recessed into the post. In addition, deeper mortises are required to accommodate the two clips.





BUILDING **CHAIRS**]

Chairmaking Basics

The right approach combines efficiency, comfort, strength, and beauty

BY KEVIN RODEL

I designed this chair in 1993 for a competition sponsored by the Maine Arts Commission. My intention was to design a chair that would be sturdy, comfortable, and clearly derivative of Arts and Crafts styling but still compatible with contemporary interiors. Understanding how this chair goes together will provide you with the building blocks for making other styles of dining or library chairs. This chair is made of white oak, though I've made the same design in cherry and walnut.

Because I wanted the chair to function as both a dining chair for long, leisurely meals and as a reading chair for a desk or library table, an upholstered seat was a must. The degree of back slope, depth of seat area, arch or curvature of the back rest, and other critical dimensions also contribute to the

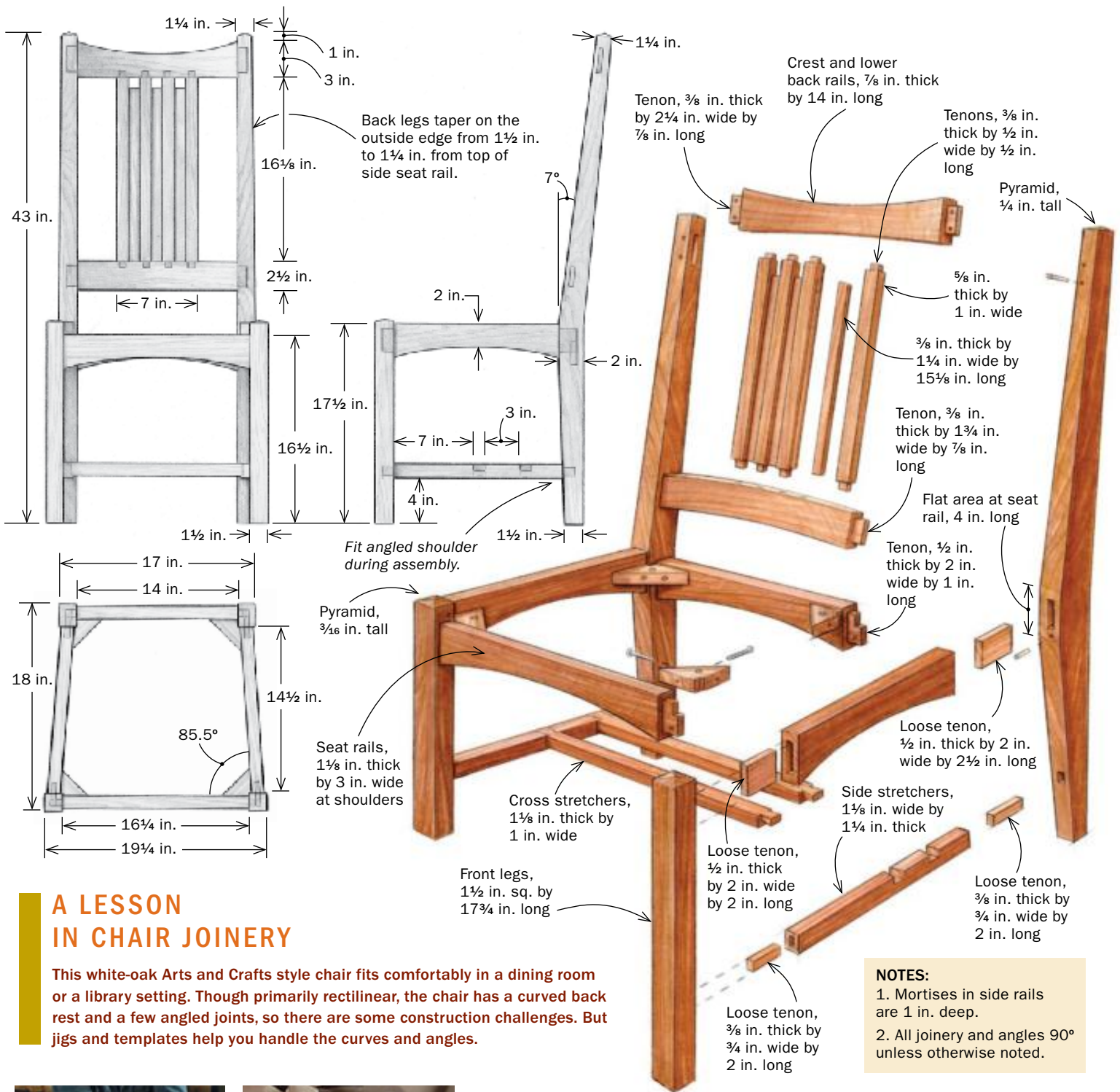

A LESSON IN CHAIR JOINERY

This white-oak Arts and Crafts style chair fits comfortably in a dining room or a library setting. Though primarily rectilinear, the chair has a curved back rest and a few angled joints, so there are some construction challenges. But jigs and templates help you handle the curves and angles.



Clamp the jig to a bench to rout the leg shape. A long bearing-guided bit can do the job in one pass; a shorter bit requires you to flip the jig and make two passes.

TWO-SIDED JIG FOR ROUTING BACK LEGS

Each leg is secured in the jig by screwing into the areas to be mortised, so mark out mortise locations on both faces.

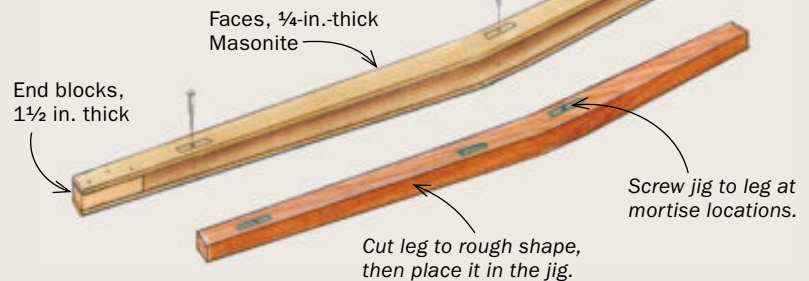

Router box simplifies mortising

This jig allows you to cut angled and straight mortises in the legs with a plunge router. It also allows for mortising for the loose tenons in the ends of the side rails.

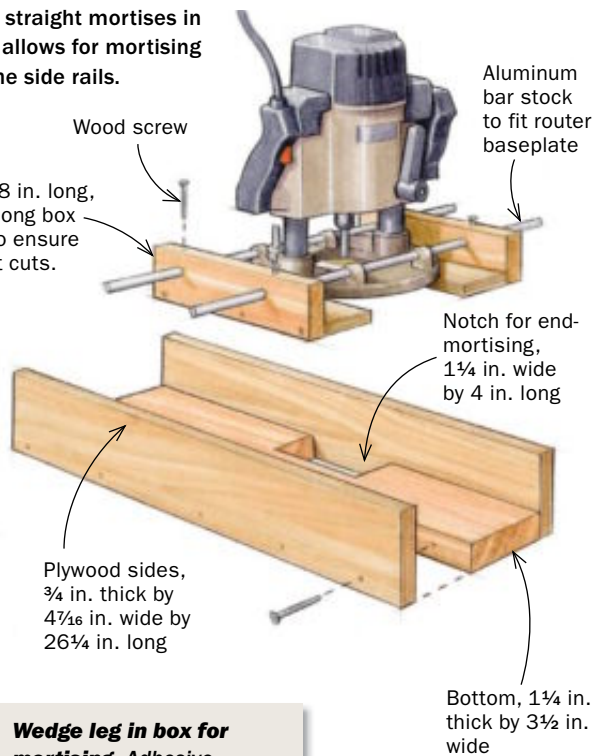
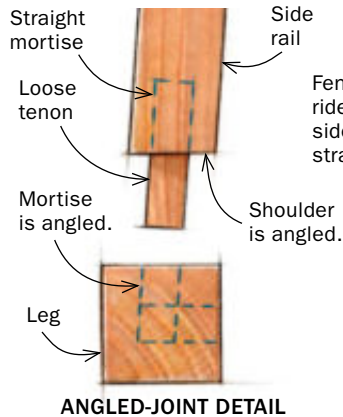

Wedge leg in box for mortising. Adhesive-backed sandpaper prevents the wedges from slipping.

comfort. I use jigs to duplicate curved and angled parts, and to create accurate angled joinery. These jigs will come in handy if you decide to build a set of chairs.

Shape the back legs using a template

First, trace the back legs on the stock using a full-size template made from 1/4-in.-thick Masonite. Rough-cut the legs to shape using a jigsaw or bandsaw, being careful to leave the line. The only cuts that should be exactly to the line at this point are the top and bottom cross-grain cuts.

For final shaping, mount the back legs in a template-routing jig (see photos and drawing, p. 55) that works with both legs. Use a large-diameter, bearing-guided straight bit (1/2 in. or more). Amana makes a 1 1/8-in.-dia. by 1 1/2-in.-long bit with a top-mounted ball-bearing guide (part No. 45468) that allows you to shape the leg in one pass.

Once you have both rear legs shaped, cut the front legs to length. Now you're ready to lay out and cut the mortises.

USE AN ANGLE BLOCK FOR SIDE-RAIL MORTISES



Angle block orients the leg at 85.5°. Set the block against one side of the leg before adding the wedges. Then cut the mortise with a plunge router.

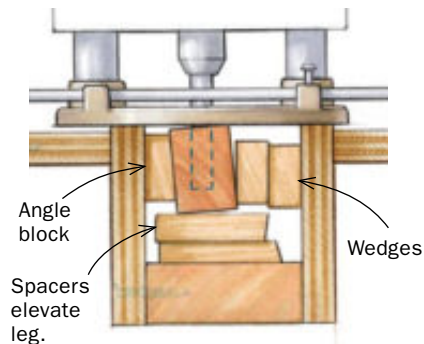

USE THE BOX FOR END GRAIN, TOO

The front and back rails meet the legs at 90° and have standard tenons. But the side rails meet the legs at an angle. Instead of cutting angled tenons, mortise for slip tenons.



Start by angling the ends of the rails. Cut the side rails to length at 85.5°, paying careful attention to the orientation of the angle cuts.

Angled mortises made easy

It is certainly easier to cut straight, 90° mortises and tenons. But to conform to the body, the chair must have some angled joinery. I've limited the angled joints to the side rails and the lower side stretchers.

The easiest and most consistent way to cut the angled joint is to bore the mortise in the leg at the required angle. Then you can simply crosscut the ends of the adjoining rails at the same angle, cut a straight mortise into the end grain of the rails, and glue in a slip tenon.



Square up the mortises. Use a chisel and mallet and pare to the line.

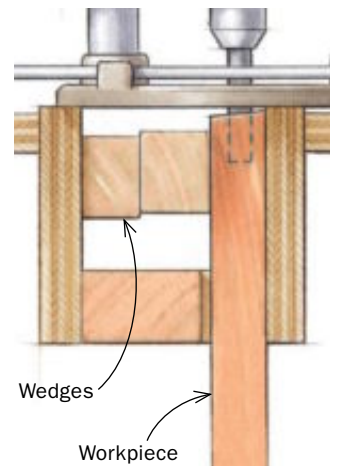

Mortise the ends of the rails. These mortises are easily cut by wedging the rail vertically in the router box.

The angled mortises in the front and rear legs can be cut using a plunge router and a router mortising box (see photos and drawings, facing page). You can use the mortising box, a mortiser, or chisels to cut the straight mortises.

Now add the decorative details on the rear legs. Taper the outside faces on the bandsaw and plane to the line. Cut the shallow pyramid heads on both the front and rear legs. Finally, cut the mortises for the square pegs in the crest rail.

Side rails meet the legs at an angle

With the legs complete, begin working on the seat rails—front, back, and side. The rail-and-seat structure takes the brunt of the load, so use care when fitting the tenons.

The front and back rails meet the legs at 90° and have standard tenons. The side rails, which are angled into the front and back legs, are attached with slip tenons.

Cut the side rails to length at 85.5° at the shoulder line (see left photo, above). The rail should look like a long, thin parallelogram, not a trapezoid. Next, lay out and cut the mortises on the ends for the slip tenons using the router box. After mortising, fit and glue the loose tenons into the side rails.

Template ensures consistent curves in all of the chair rails

You want the arches in the rails to be consistent, so cut them to shape using templates made of ¼-in. Masonite. You'll need three templates for the seat-rail arches: one



Glue the loose tenons in the side rails. The tenon should fit with a bit of hand pressure. If you have to beat on it with a mallet, the fit is too tight; if it drops out, it is too loose.



Now rout the side-rail arches. Rough-cut the curve on the bandsaw. For consistency, screw a router template to the tenons, and secure the assembly to the bench for routing.

Make the back-rest assembly

The rails of the back rest are curved on the front and back faces, and the crest rail is arched on its top edge. Both rails are mortised to hold the back splat, a curved assembly of narrow strips.

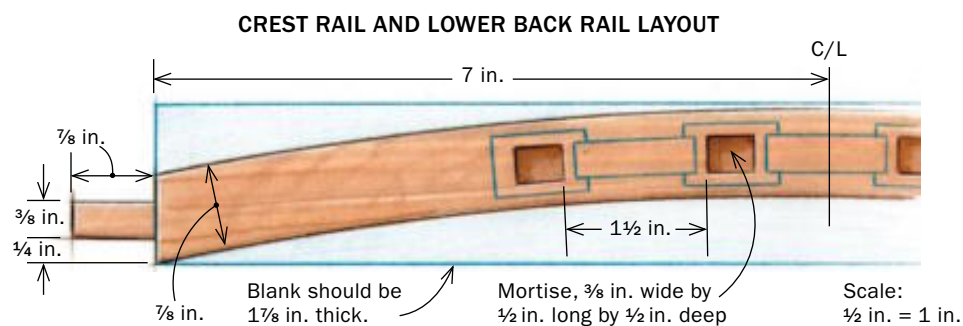

CUT THE JOINERY BEFORE SHAPING THE UPPER RAILS



Cut the tenons and the inside curve of the rails before mortising. Mark the locations of the back-splat mortises using a template and drill them out on the drill press (left). A curved fence helps support the tall workpiece. Next, following the lines marked from the template, square up the mortises (right).



Arch the top of the crest rail next. Re-use the rear seat rail template to trace the arch along the top of the crest rail, then rough out the shape on the bandsaw.

each for the front, sides, and back. Use the templates to draw the arch on the seat rails, then use a bandsaw to remove most of the waste. Now use a bearing-guided straight bit to template-rout the arches.

The two curved back rails require a few more steps than the seat rails. Mill up extra-thick blanks and cut the offset tenons on the ends. For consistency, it helps to make a template showing both the inside and outside curves of the rail (see drawing, left). Trace the concave curve first, then remove the waste with a bandsaw, and clean up the surface using a spokeshave or sandpaper. If you prefer, you can use the template to make a jig to clean up the surfaces using either a router or shaper. Now use a marking gauge to scribe the 7/8-in. thickness of these rails, referencing off the just-milled front faces.

Before shaping the crest and bottom rails further, lay out and cut the four small mortises for the back splat (see photos, left).

The next operation is to arch the top of the crest rail using the same method and template used to shape the back seat rail (save the cutoff). Finally, cut the convex curves of the crest and bottom rails on the bandsaw, just leaving the line. Clean up these faces with a disk or belt sander.

Back splat serves as the focal point

The back splat is a curved assembly of 1-in.-wide strips, with three 1-in.-sq. openings at the top, that conforms to the



Finally, cut the curves on the backs of the top rails. Leave the scribe line, and clean up the surfaces with a belt or disk sander.

MILL AND GLUE UP THE BACK SPLAT

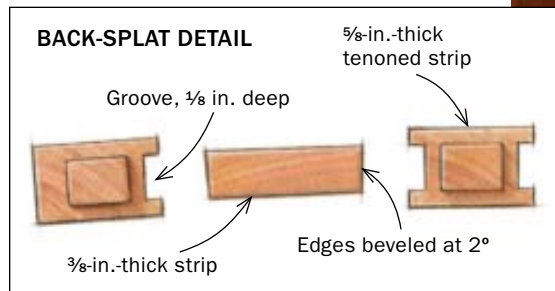

Tenoned strips are grooved on both sides. Cut and fit the $\frac{5}{8}$ -in.-thick strips into the mortises in the rails, then rout the $\frac{3}{8}$ -in.-wide groove, $\frac{1}{8}$ in. deep, into their edges. The outside strips are grooved only on the inside edge.



Bevel the thin strips. After ripping the $\frac{3}{8}$ -in.-thick strips to width, joint a 2° bevel on their edges to allow the splat to curve.



Use the crest rail and the bottom rail to guide the glue-up. Apply glue with a syringe to avoid squeeze-out. Do not glue the splat to the rails yet. Once the back splat has dried, go ahead and glue it to the crest and bottom rails, then assemble the rest of the chair back.

shape of the crest rail and the back rail. For this element, you'll need two blanks, $\frac{3}{8}$ in. and $\frac{5}{8}$ in. thick and wide enough to cut the required number of strips.

Dry-fit the crest rail and the back rail into the legs and measure vertically between them. Add 1 in. to that measurement for the $\frac{1}{2}$ -in. tenons, and cut the $\frac{5}{8}$ -in.-thick blank to length. Now cut $\frac{3}{8}$ -in.-thick tenons on each end, rip the board into four 1-in.-wide strips, and cut the remaining tenon shoulders on the strips.

Next, cut the grooves for the $\frac{3}{8}$ -in.-thick strips, beginning 1 in. from the top shoulder line, and square up the top edge with a chisel. Now cut the $\frac{3}{8}$ -in.-thick blank to the same length as the grooves, rip it

into strips, and joint a 2° bevel along each edge of the thin strips. Sand all the parts to P220-grit, and glue up the back splat using the crest rail and bottom rail as glue-up jigs. To avoid squeeze-out, use a glue syringe to apply the glue.

Glue up the front and rear assemblies

While the back-rest assembly is drying, glue up the two front legs and the front seat rail. Notch the tenon on the front rail to give clearance for the side-rail tenons. Be sure the legs are parallel with no toe-in or splay as you clamp up the assembly. Reinforce the joints with a $\frac{3}{16}$ -in.-dia. dowel hidden on the inside face. When the glued-up back splat has cured, remove

the crest and back rails, apply glue to the mortises, and glue these parts together. To help with the clamp-up, use the arch cutoff as a caul.

Allow this assembly to dry, then glue it and the back seat rail to the rear legs. Again, reinforce the rear seat tenons on the inside with a $\frac{3}{16}$ -in.-dia. dowel. While you are at it, install the $\frac{3}{16}$ -in. pegs in the tops of the rear legs through the $\frac{1}{4}$ -in.-sq. peg holes to reinforce the crest rail mortise-and-tenon joint.

Install the lower stretcher assembly

The lower stretcher assembly not only helps stabilize the lower part of the chair against racking forces, but the exposed

Fit the lower stretchers

The lower stretchers help stabilize the chair against racking forces. The side stretchers attach to the legs with slip tenons, and the cross stretchers connect to the side stretchers via half-lapped dovetails.



Cut the rear shoulders first. The rear shoulders of the stretchers are angled 85.5° horizontally. In addition, they must be angled vertically to match the leg taper. Start by dry-clamping the chair, and set a bevel gauge to the vertical angle (left). To cut the rear shoulder on the tablesaw (right), tilt the blade to 85.5° , then use the bevel gauge to set the angle of the miter gauge.



Creep up on the fit. Cut the front shoulders with the miter gauge set to 90° and the blade tilted to 85.5° . Leave each stretcher a little long and take light crosscuts until the ends slide up into place and align with the mortise locations.



Install the cross stretchers after glue-up. Cut the half-lapped dovetails on the cross stretchers, then scribe them onto the side stretchers.



Screw in the corner blocks. The blocks help reinforce the corner joints and serve as anchors for the seat frame.

SLIP SEAT COMPLETES THE CHAIR

The chair has a leather-upholstered seat, installed after the chair has been fumed and finished. The frame is screwed to the corner blocks between the rails.

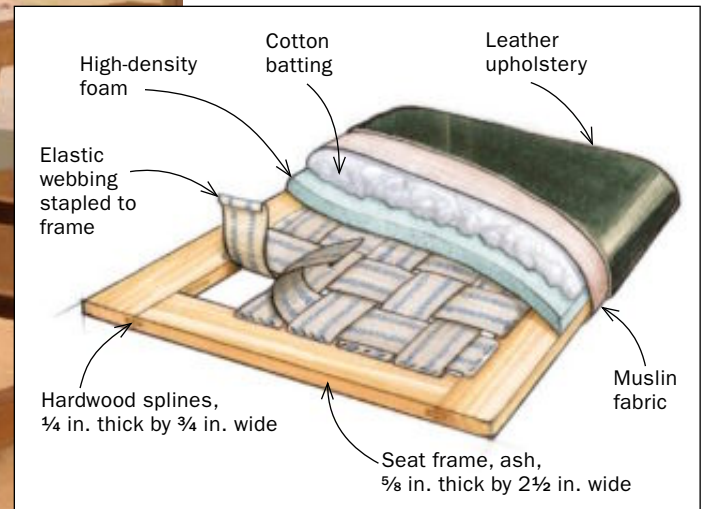

direction. Now cut the forward ends of the stretchers at 90°—with the miter gauge at 90° and the blade still at 85.5°—sneaking up on the length until they just fit.

Next, cut a 3/8-in.-wide mortise, centered in the end grain of each stretcher and about 3/4 in. deep. Dry-fit the slip tenons. When the fit is perfect, glue up the chair.

While this glue is setting, mill up the two cross stretchers. Once the stock is milled to width and thickness, locate where each

dovetail slots in the side stretchers using a handsaw and chisels. Once the dovetail sockets have been cleaned out, glue the cross stretchers in place.

After the glue has set, sand all the stretchers flush on their upper faces, and go over the chair thoroughly for any residual glue squeeze-out and touch-up sanding. Finally, make up the corner blocks and screw them to the inside corners, flush with the upper edges of the front and rear seat rails. Add an additional screw hole up through the body of the corner blocks before attaching them. This will be used to attach the upholstered slip seat to the chair.

The very last item before finishing is installing the pyramid-shaped decorative pegs in the crest rail. I use ebony, but any hardwood species will work.

This white-oak chair is fumed, and finished with a topcoat of Tried & True linseed oil. The seat is upholstered in leather from Dualoy Inc. (www.dualoy.com). □

Kevin Rodel is a furniture maker and teacher in Brunswick, Maine.



[FineWoodworking.com](http://www.finewoodworking.com)

Watch a free video of this chair being built, or purchase the full-size plans. Go to www.finewoodworking.com/buildingfurniture.

cross stretcher will meet the side stretchers. Cut each one to length, leaving them about 1/8 in. extralong on both ends.

Hold a cross stretcher in place, and locate the shoulder cut by scribing a line on the underside where it meets the side stretcher. Cut a half-lapped dovetail on each end of each cross stretcher. Set the cross stretchers in place, then scribe and cut out the

Chest of Drawers

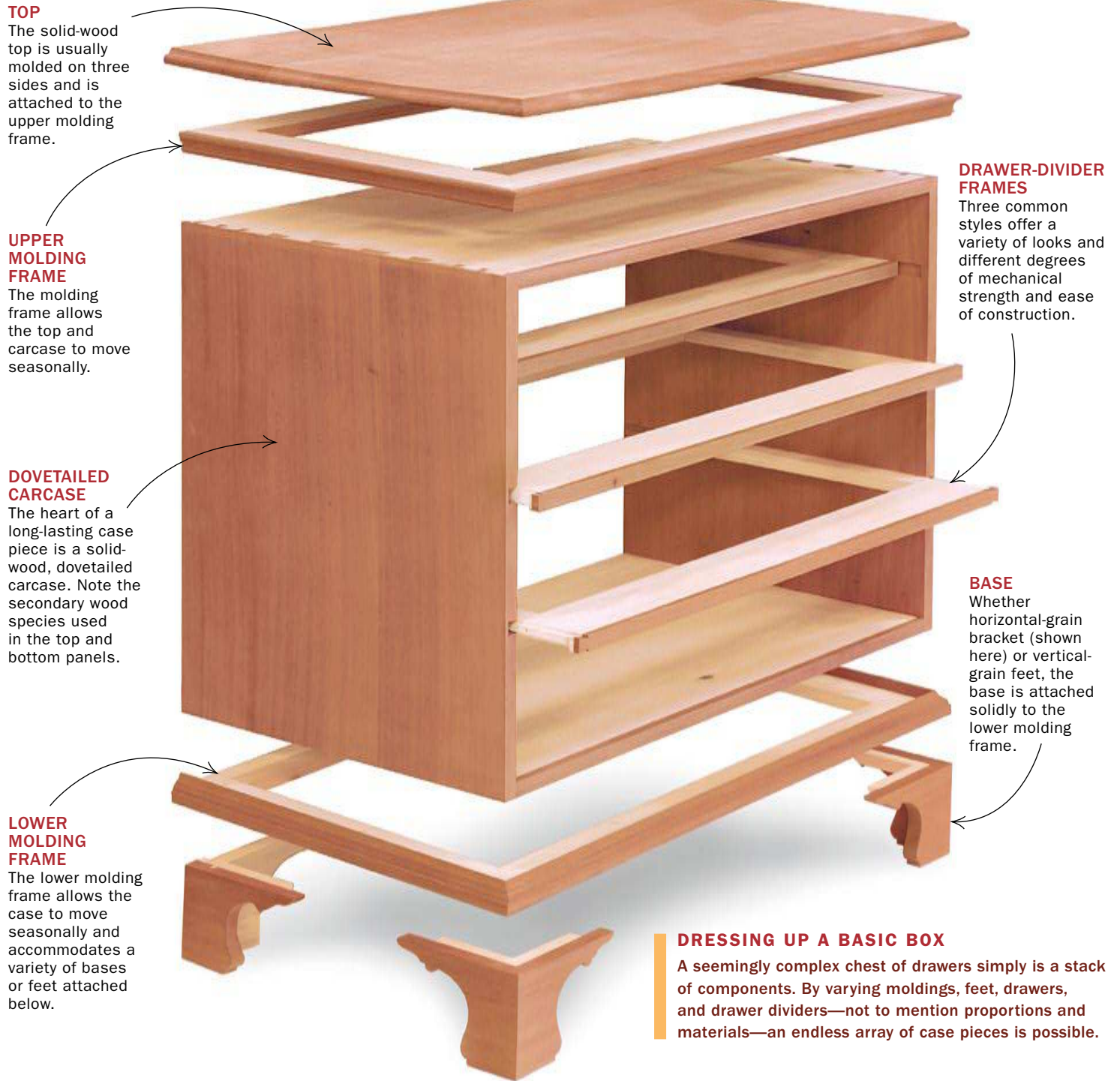

TOP
The solid-wood top is usually molded on three sides and is attached to the upper molding frame.

UPPER MOLDING FRAME
The molding frame allows the top and carcass to move seasonally.

DOVETAILED CARCASE
The heart of a long-lasting case piece is a solid-wood, dovetailed carcass. Note the secondary wood species used in the top and bottom panels.

LOWER MOLDING FRAME
The lower molding frame allows the case to move seasonally and accommodates a variety of bases or feet attached below.

DRAWER-DIVIDER FRAMES
Three common styles offer a variety of looks and different degrees of mechanical strength and ease of construction.

BASE
Whether horizontal-grain bracket (shown here) or vertical-grain feet, the base is attached solidly to the lower molding frame.

DRESSING UP A BASIC BOX

A seemingly complex chest of drawers simply is a stack of components. By varying moldings, feet, drawers, and drawer dividers—not to mention proportions and materials—an endless array of case pieces is possible.

Case furniture based on a dovetailed box is found in a wide range of styles and periods. While the details vary, many pieces can be built using similar construction solutions. When I build a case, I work from a firm set of ideas—both traditional and modern—that I've found to be reliable and efficient.

The techniques required to make a chest of drawers are common knowledge to most woodworkers: dovetails, dadoes, miters, mortises, and tenons. The complex appearance is the result of a straightforward sequence of simple steps.

At its most basic level, a chest of drawers is a stack of separate assemblies. However, based on moldings (or lack thereof), leg treatments, drawer styles, proportions, and materials, a wide variety of case pieces is possible. Like my other articles in this magazine, "Tables with Drawers" (pp. 42-47) and "Classic Sideboard" (pp. 70-77), this

Build a strong case and then change details to suit the style

BY WILL NEPTUNE

article describes a basic, proven construction approach. The details are up to you.

Start with a dovetailed case

When preparing your primary stock for the sides of the case, put aside strips to be used later to edge the top and bottom case panels as well as the drawer dividers.

Using wood from the same board will give a uniform look to the case.

A chest of drawers begins with four panels: a top, a bottom, and two sides. The strips of primary wood that edge the top and bottom can be glued onto the secondary-wood panels after rough-milling. Match the grain direction of all parts during glue-up so they can be finish-milled as one piece.

The case is joined with half-blind dovetails, so lay them out for strength, not appearance. You may want extra tails near the edges, especially the front, to resist loads that could pop the front shoulder.

Another trick makes the joinery for the back a little easier. Run the rabbets for the back boards all the way up the sides without stopping. Then rip the top and bottom panels to be flush with this rabbet; the back boards will extend all the way up to the top and bottom of the case but will

CARCASE AND BACK CONSTRUCTION

The case is joined with half-blind dovetails, which are hidden from view. Traditionally, the back consists of shiplapped boards.

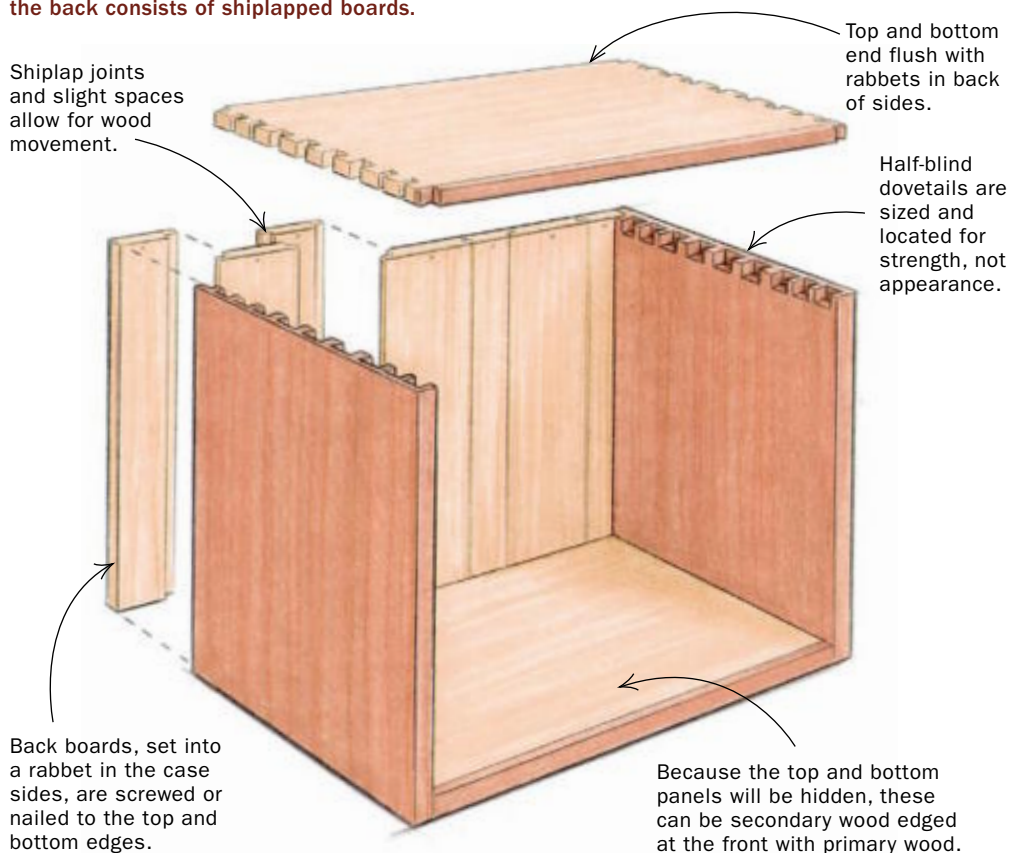

BACK-PANEL OPTIONS



A more attractive frame and panel can fit into the side rabbets.

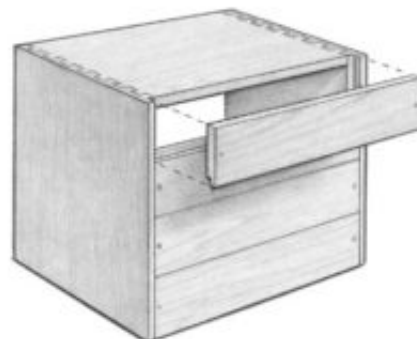

Horizontal shiplapped back boards help prevent tall sides from bowing outward.

DRAWER-DIVIDER FRAMES

Only the front 3 in. or 4 in. are glued to the case, allowing the case sides to move. Choose a frame type based on the desired look and the need for strength.

STOPPED DADOES

Basic stopped dadoes offer a clean, contemporary look and the easiest construction.

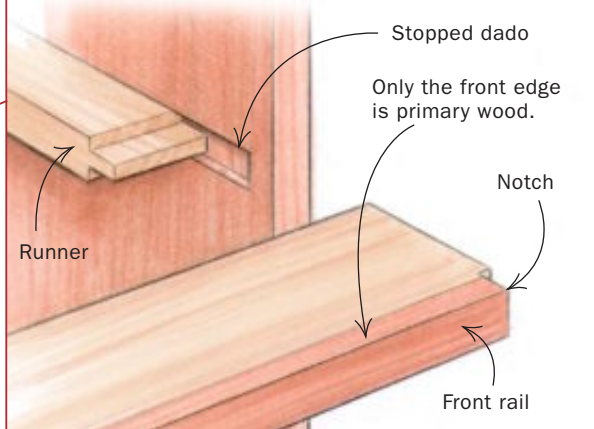

STEPPED DOVETAILS

Stepped dovetails offer a more traditional look and a mechanical connection between the case sides.

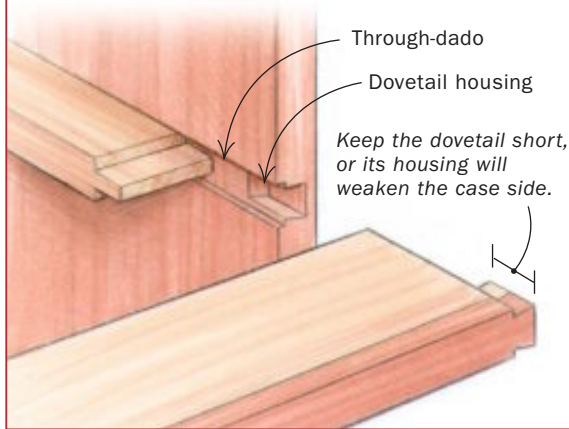

DOVETAILS WITH HIDDEN DADOES

Dovetails with hidden dadoes not only tie the case sides together but also offer a clean look.

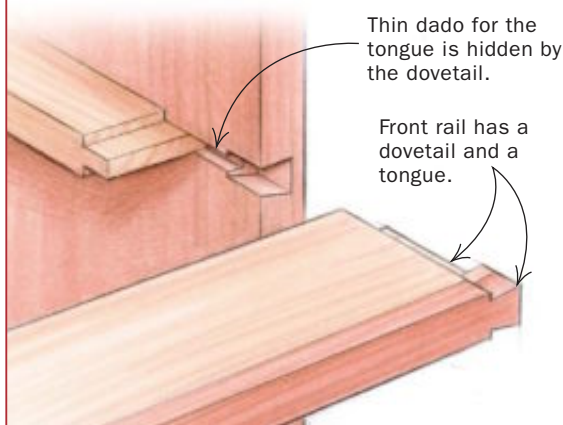

be hidden by the true top, which goes on later. The back boards, lapped in some way to allow for wood movement, will be screwed or nailed to the case.

Drawer dividers: three options

Once the case dovetails have been cut, fitted, and dry-clamped, it's time to work on the system of drawer dividers and supports. For function and appearance, the divider frames must stay flat. Again, secondary wood can be used for all but the front edges. Choose the inner secondary wood for stability. Avoid secondary wood that was significantly bowed in the rough, and make the front divider wide for extra stiffness. I make the fronts 3½ in. to 4 in. wide, and the less-critical back dividers 2½ in. to 3 in. The runners can be narrower, about 2 in., because they are held in dadoes. Leave the parts a bit thick to allow for leveling the frame after gluing.

Although there are other divider systems, typically I use one of the three systems shown at left. For all three types, I prefer to glue up the mortise-and-tenoned frame first and fit the unit to the case dadoes. But you also can fit and glue the pieces together in the case, using the dadoes to align the parts.

One last note: Glue up the case after the dadoes have been cut but before building and fitting the divider frames.

Stopped dadoes—This simple approach offers a streamlined look and straightforward joinery. The main liability

NOTCHING THE DIVIDER



A divider in a stopped dado is inserted from the back. The front rail must be notched to reach the front of the case.

is the lack of sound glue surfaces between the frame and the case. Usually this isn't a problem, but for a tall case or one with unstable wood, you may want one of the other frame systems that use lap dovetails to tie the ends of the case together. The other types also offer the traditional look of exposed joinery.

Start by laying out and cutting the dados, which are about $\frac{1}{4}$ in. deep. I do the layout while the case is dry-clamped, using a story stick to avoid measuring errors. The goal is to get the pairs of dados at equal height and parallel to the inside faces of the top and bottom. Square up the front ends of the stopped dados at an equal distance from the front edges of the case (about $\frac{1}{2}$ in.). The front of the frame should be flush to the case edge, but the back should be inset about $\frac{3}{8}$ in. from the rabbets to allow the sides to shrink. Gauge the length of the dividers from the bottom of the dados, and cut them about $\frac{1}{32}$ in. undersize to make the frames a bit easier to fit.

To connect the divider frames, I use mortise-and-tenon joints. When clamping and gluing up the frames, take diagonal measurements to check for squareness, and be sure that the frames are flat. A good tip is to level the joints on the top of the frame first. Then, as you test the frame and slide it into the dados, you can do all of your fitting from the bottom. The front 3 in. to 4 in. of the frame should be snug, but the rest can be eased to make it slide in the



DRAWERS

The two common drawer styles are flush and lipped. On the lipped style, the drawer front covers the gap for a more refined look.



Match the divider to the drawer. The dovetail with hidden dado offers a clean look for flush drawers (above), while lipped drawers look better with the stepped dovetail (below).



dados with less drag. You will need to cut a shoulder in the front of the divider frame so it can extend past the stopped dados to the front of the case.

Stepped dovetails—Adding lap dovetails to the front of the divider frame gives it a strong mechanical connection to the

case sides. The front rail will resist forces pushing the case sides outward, and it can be used to pull in bowed sides slightly. This traditional solution is called a stepped dovetail because both the dado and dovetail are visible at the front. I like to use this joint with lipped drawers, where the

Scribe for perfectly fitted dividers

DOVETAILING THE CASE SIDE



Slide the divider to the front of the dado and scribe the shoulder. Then cut the notch in the front rail.



Dovetailed dividers go in from the front. The dado is cut first; the dovetail housing is cut second.



Slide in the dadoed section as far as possible. Then transfer the layout of the dovetail onto the case side.

MOLDINGS AND CASE TOP

Molding frames are the best way to attach moldings across the grain of the case sides and the top.

Elongated screw holes along the sides and back edge of the molding frame allow the top to move seasonally.

Elongated holes for the screws that attach the case to the molding frame allow the case to move.

Round holes along the front edge of the case and molding frame keep all three aligned where it counts most.

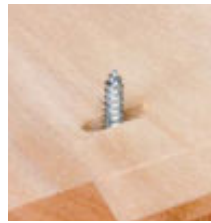

Elongated screw holes are the answer. These are elongated along the bottom side only, allowing the pieces to shift against each other without coming apart.

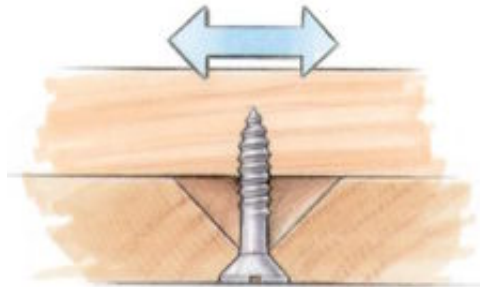

side lip matches the dado depth. Be prepared to spend extra time on these joints, though, because there are many surfaces that must fit at the front edge, and any gaps will be obvious.

This joint uses a shallow (about $\frac{3}{16}$ in. deep) through-dado, with a lap dovetail at the front extending into the case side.

Start by penciling in the dovetail location on the case sides. This gives the length of the front rail. Before gluing up the frame, notch the front rail to leave the stubs for the dovetails. Now build the rest of the frame and shape the dovetails on the front stubs. This joint will show any gaps, so work carefully and test the dovetail fit as you pare. When you install the frame, rub the rear part of the dado with paraffin wax so that any glue that drags back won't keep it from floating.

Lap dovetail with hidden dado—The third frame type uses a narrower through-dado that is hidden at the front by the lap dovetail. This dovetailed frame gives the same mechanical strength as the stepped version but has a cleaner look. When used with flush drawers, it has a neat, logical appearance.

This system has another advantage over the stepped dovetail. Because the dovetail covers the dado, there are fewer surfaces that must close up. Use a standard dado size that is $\frac{1}{16}$ in. or so smaller than the base of the tail, and make the dados about $\frac{1}{4}$ in. deep.



The correct sequence. First, attach the molding frame to the top (above) and then to the case using the elongated holes only. Last, screw all three parts along the front edge (right).



FLAT VS. RABBETED MOLDING FRAME

The type of molding frame will determine how much of the top or bottom edge of the carcass is visible.

FLAT FRAME

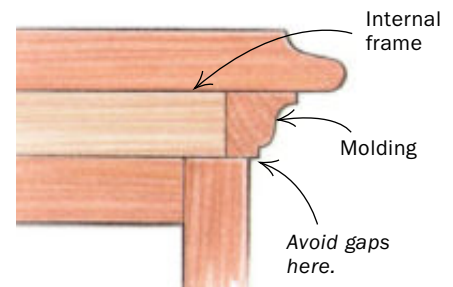
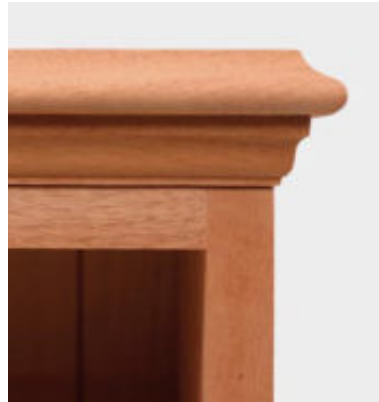
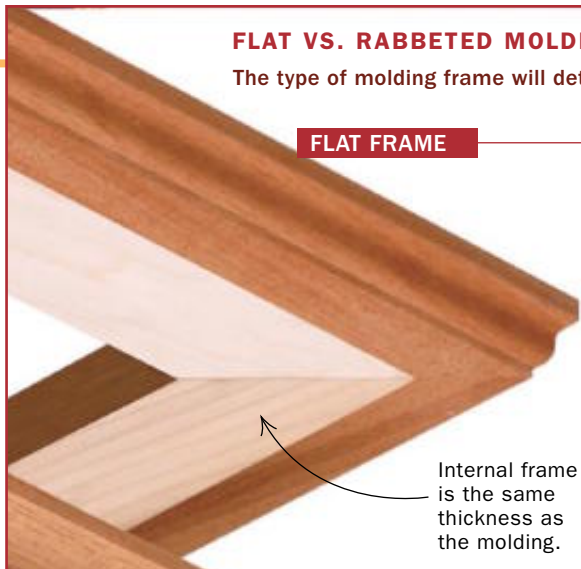

A flat frame is easier to build and fit. But it shows the entire case edge and must lie perfectly flat.

RABBETED FRAME

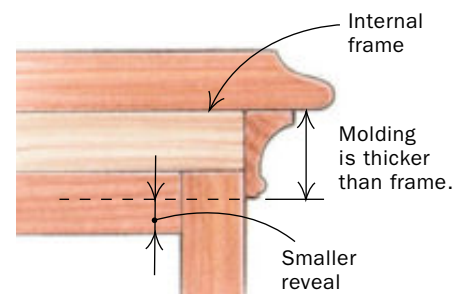
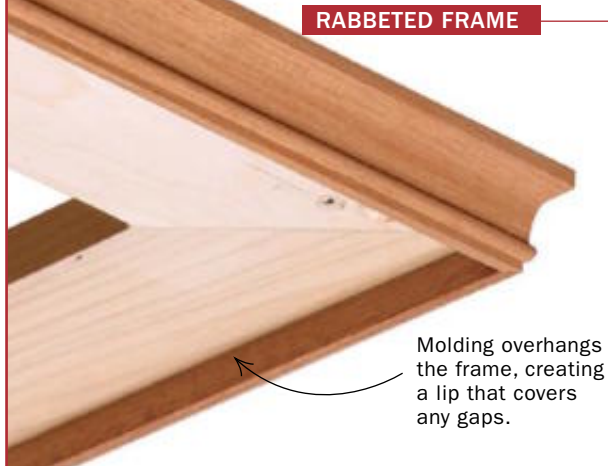

Rabbeted frame leaves the carcass reveal up to you. And if the frame doesn't lie perfectly flat, the gap won't show.

Once the frame has been made, you need to form the tongues, stopping them at the front and leaving extra wood for the tails. Because the tongues and dados will be hidden, only the shoulders for the dovetails need to be tight, and the tongues don't need to bottom out in the dados; however, the tongues should be snug in thickness, especially at the front.

A few tips for the drawers

Once the frames have been fitted and glued in, you may build and fit the drawers by any method you're comfortable with. Drawer fronts, of course, have a lot to do with the appearance of a chest, so look over the wood and plan the overall grain pattern before you begin.

This article presents two options: a flush drawer and a lipped drawer (see top photo, p. 65). Both types need stops (the fragile lip molding is there only to cover the clearance gaps). One reason why I

locate the stop blocks on the rear dividers is that it's easy to clamp them in place while testing the drawer. Just remember to size your drawers to make room for the stops. But the great trick here is that putting the stops on a floating frame keeps the drawers flush at the front even as the case changes depth through the seasons.

Ease the transitions with moldings

Visually, top and bottom moldings have a powerful effect. They frame the case with their strong horizontal lines and play of light. Their projection at the bottom gives the base a sense of stability and strength. An upper molding provides a transition to the overhang of the top and also balances the bottom molding.

Many times you'll see old work with moldings attached to the case itself, but these tend to fail over time as the case shrinks. Using separate frames for the moldings will give the same appearance

while allowing for case movement. These top and bottom frames can be built using either of two methods (above).

Both methods can use secondary wood for the inner part of the frame. The first is a simple mitered frame with a molded edge. A more complex, rabbeted frame system wraps over the sides and front edge of the case. With this system you can choose how much of the front case edge shows, giving a wider range of effects.

Both frame systems should overhang the back to allow for expansion of the case. Fasten the frames to the case with screws, tight along the front but with elongated holes along the sides and back to allow the case to move.

Flat frame is quicker to build—The first step for the flat frame is to know the exact dimensions of the molding you want, its projection from the piece, and the width of the primary wood. The next step is to glue the primary-wood strips onto the

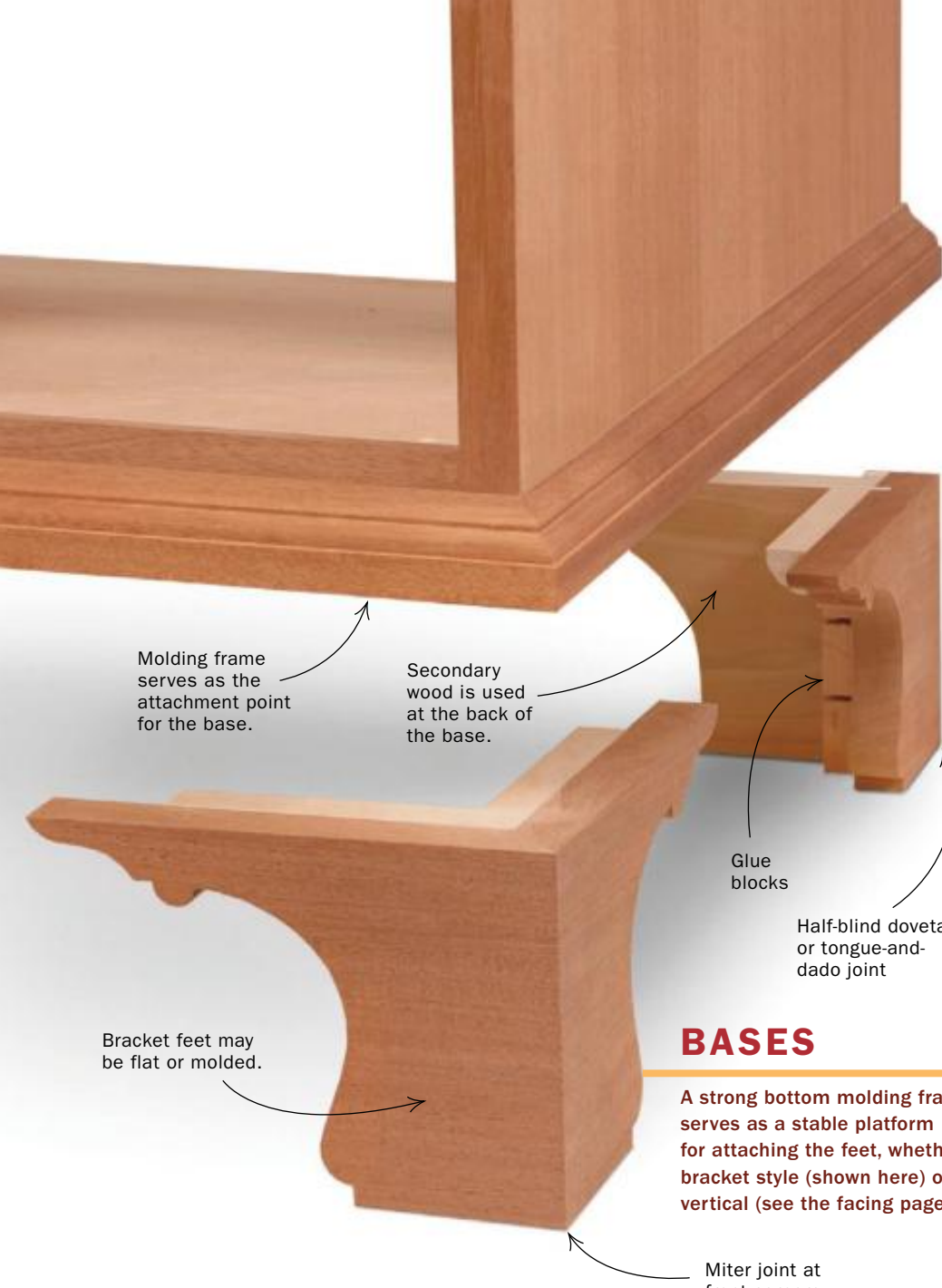

Molding frame serves as the attachment point for the base.

Secondary wood is used at the back of the base.

Glue blocks

Half-blind dovetail or tongue-and-dado joint

Bracket feet may be flat or molded.

BASES

A strong bottom molding frame serves as a stable platform for attaching the feet, whether bracket style (shown here) or vertical (see the facing page).

Miter joint at front corners

inner-frame stock and then mill the blanks to thickness.

Get the front miters fitting correctly before mortising in the flat, unmolded rear rail. Join the mitered corners with biscuits or stopped splines. Last, mold the desired profile on the outside edge.

Build the rabbeted frame in two parts—The second frame system is built in two stages. The inner, secondary-wood frame is thinner than the molding, based on how much of the case edge you want covered. I build the frame first, slightly oversize, then trim it to fit the case exactly. Let the back edge overhang to hide seasonal case expansion.

Now form the rabbet with the three thicker molding blanks. Dry-fit the parts carefully, making sure the miters come together exactly at the corners of the case, keeping the end pieces long at first to allow room for adjustment. Then glue the blanks to the edges of the frame and mold the profile. The frame is held with screws as before, with elongated holes to allow for movement.

Attach the top

The top of the case is often molded on three edges and usually has an overhanging back to hide shrinkage and to avoid a large gap between the case and the wall.

If a molding is used below the top, it's important to let the case, the molding frame, and the top move independently. All three parts are held tight with screws along the front edge to keep the miters and reveals constant. But along the sides and back use elongated screw holes between the frame and top, as well as the case and frame. People commonly lift cases by the top edge, so all of these connections must be very strong.

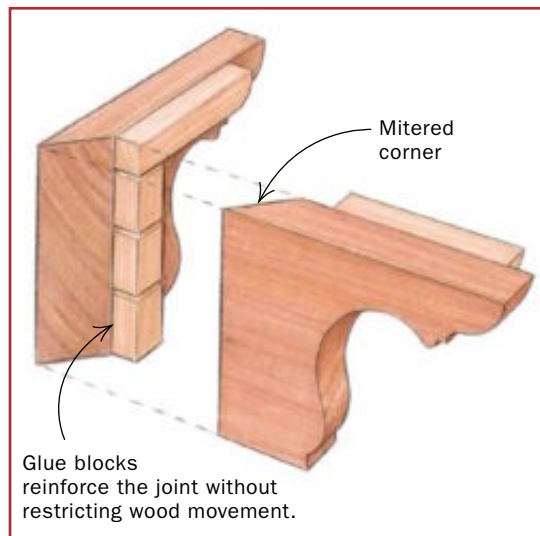

Mitered corner

Glue blocks reinforce the joint without restricting wood movement.

BRACKET FEET

Molded or unmolded, with a wide variety of cutouts, bracket feet are used in many periods and styles. They are glued to the base molding frame (or attached to the case).



FLAT BRACKET FOOT



OGEE BRACKET FOOT



FLAT BRACKET BASE



Period or contemporary? The choice of moldings, drawers, feet, and hardware offers a wide range of design possibilities.



Details define the style

This construction system will produce a wide variety of case pieces, depending on the combination of the individual elements. An 18th-century piece (top) combines moldings, drawers, and feet common to that period.

Lipped drawers soften the line of the front. A wide base molding and classic ball-and-claw feet give the piece a broad stance. The top is carefully dimensioned and molded to relate to the rest of the piece.

The bottom chest of drawers has a more contemporary look with harder lines and surfaces, including a flush front. The curved, tapered legs flare outward, broadening the stance without looking heavy. The base and top moldings are beveled to complement the style. And the top is chamfered to make it appear thinner and to match the other elements.

These examples are the tip of the iceberg. You could make the case taller than it is wide, or use a different array of drawers. And consider the effect of other wood species or figured wood for the drawers.

Choose a base

The final bit of woodworking is to prepare a base. For this article, I built the two most common systems, each adaptable to many leg styles. Bracket feet are cut from blanks with horizontal grain and are mitered at the front. The other leg style has vertical grain, which usually features narrower legs, often braced by flanking side pieces.

Bracket feet—Start the flat bracket feet with one long board about $\frac{3}{4}$ in. thick. The six blanks should be taken out of a single board, if possible, so the grain pattern wraps around the base, matching at the miters. It's also nice to use the same board here as you did for the base molding to help hide the joint between the base frame and the feet.

The rear feet are braced with secondary wood. The joint at this back corner can be half-blind dovetails or, more simply, a tongue and dado. The miters for the front parts can be reinforced with a spline, but usually it's enough just to butt them.

Cut and dry-fit the joints before cutting the foot profile. The assembled feet are glued to the base frame. All of the foot and base joints should be reinforced with glue blocks. A single vertical block can cause the foot to crack, so I use three short blocks with $\frac{1}{8}$ in. of space between them.

Vertical feet with support pieces—The second construction system is seen in the saber leg with flanking transition pieces. Its main advantage over bracket feet is that the vertical grain direction allows a strong foot of a much smaller size.

Generally, a round or square tenon is cut in the top of the foot blanks to match a hole or mortise that is cut through the molding frame. The mortise should be located away from the corner of the frame so that the miter joint isn't weakened. The transition pieces are tenoned into the foot. As before, these assemblies are glued to the base frame.

This sums up my approach for fine-quality casework, but many variations are possible. In fact, 10 people can use the same information to build 10 very different chests, each one a record of that maker's taste and skills. □

Will Neptune is a furniture maker in Acton, Mass., and a former woodworking instructor at North Bennet Street School in Boston.

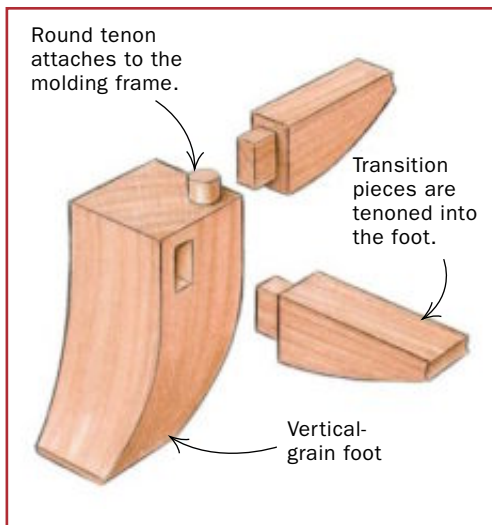

VERTICAL-GRAIN FEET

Vertical-grain feet come in a wide array of styles, from turned bun feet to 18th-century ball-and-claw feet to more contemporary saber feet. Most have flanking transition pieces.



SABER FOOT



BALL-AND-CLAW FOOT



TURNED FOOT

Classic Sideboard

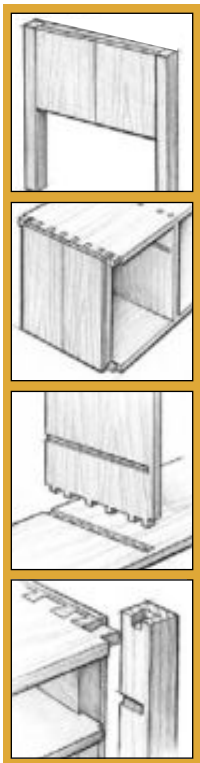

Common-sense approach
to joinery in complex
cabinets



BY WILL NEPTUNE

It is all too easy to sketch something that looks good, only to discover that you have no reasonable way to build it. You either develop overly complex construction methods or sacrifice the design you really want because it's too difficult to build. The solution is to strike a balance between design complexity and construction simplicity. It helps to start by thinking of a piece in its most basic form and then developing a single construction system that can accommodate a wide range of design options.

I tell my woodworking students that a sideboard is little more than a box with legs attached. Though it sounds over-



simplified, this approach puts things in familiar terms—everyone knows how to build a box. It becomes a question of how to build the better box.

Historically, sideboards were built using post-and-rail or frame-and-panel construction, but I prefer an alternative approach, in which the case is a dovetailed box turned on its side. My approach is less familiar, but when you start counting the joints necessary to build a frame-and-panel sideboard, you begin to understand the logic of a dovetailed design. With this method, there are fewer joints to cut, and the ones you do cut aren't seen, so there's no need to be overly meticulous.

This construction system is based on a few joinery rules: If a case part joins another at a corner, dovetail it; if one part meets along another's length, use multiple tenons. Dovetails and tenons are both strong joints that allow for wood movement and resist racking. Because all of the structural parts of the case have grain running in the same direction, the case expands and contracts together. Put simply, the case is still just a long dovetailed box with legs.

Sideboards built using this approach may vary in size, line, and style, but they retain a family resemblance based on the construction system. The mocked-up sideboard shown on these pages is the most basic variation, but it lays a foundation that can be used on more complex designs. Once you understand the construction system, you can focus on design and build in styles ranging from Federal to Arts and Crafts (see "Details for any style," p. 75).

Basic sideboard design

A sideboard is typically a case piece that's 40 in. tall or taller, a convenient working height for a standing person. The height makes anything displayed on its top more visible because it isn't overpowered by the forest of chairs surrounding a dining-room table. A sideboard is also strongly horizontal because its tall legs hold the mass of the case off the floor and because the case length exceeds the height. The open space below the case keeps the sideboard from

1. BUILT-UP ENDS

CUT SECTIONS FROM ONE THICK BOARD TO CREATE INVISIBLE JOINTS

By carefully planning the cuts, a single 2-in.-thick board can be laid out to form leg-and-end assemblies that appear to be a single solid board. The legs are cut from the straight-grained edge of the board, and the ends are book-matched and laminated from resawn stock. When the legs join the ends, you're left with virtually invisible gluelines.

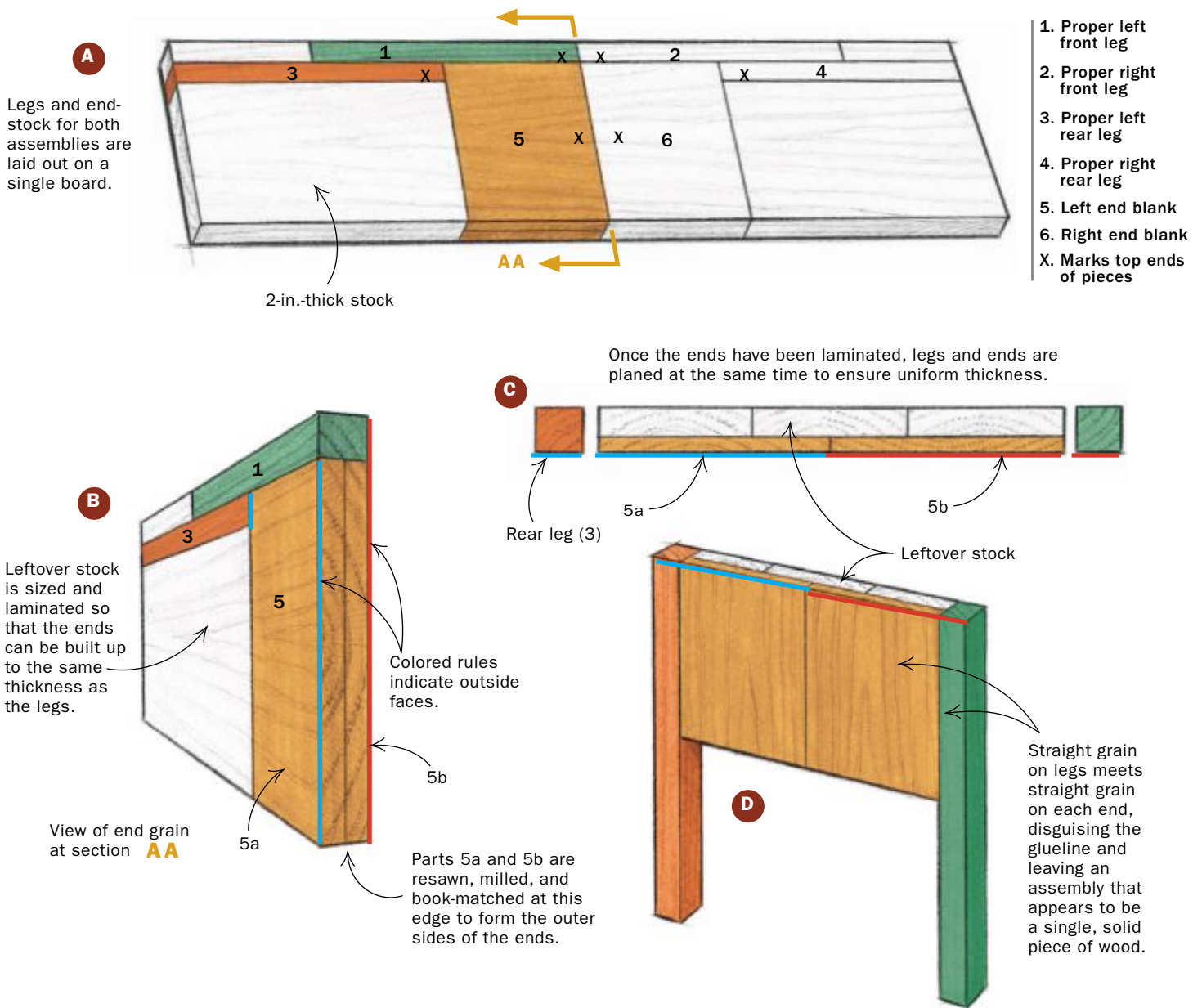

appearing too massive, an effect you get with many large case pieces. With lengths of 4 ft. and 5 ft. being common, the facade can be divided using drawers and doors (see drawings, p. 77).

In designing the mocked-up poplar sideboard seen on these pages, I wanted a simple piece with a country feel. In form, it refers to the Federal period but avoids the use of veneers, inlay, and hardware seen in period, high-style examples. To simplify construction, I decided on a small, four-

legged version without the curved facade often seen in Federal pieces. Country furniture makers made similar design choices in earlier times, using the grain and figure of local woods or even painted finishes for visual interest. These designs rely on proportion and line to create a sense of balance and harmony.

The construction system

One key feature of this construction system is the use of built-up ends, which are

thickened to the same dimension as the legs. The thicknesses of the ends provide large glue surfaces for the legs. In addition, the top and bottom join the legs and ends without having to be notched around the legs. This structural solution creates a lined interior for the cupboard areas.

The partitions that divide the facade are not only design variables, but they are also structural elements. The multiple stub tenons tying the long top and bottom together are strong insurance against

racking. All of the drawers run on frames let into stopped dados.

In a real project, if saving primary wood is important, all of the case parts other than the legs can be made of a secondary species and faced or edged with primary wood. Using a less dense secondary species also saves weight.

Using built-up ends—Even though this entire mock-up is made of poplar, I laminated the ends the same way I might for a sideboard built in cherry or mahogany. By resawing a piece of 8/4 stock, which is about 2 in. thick, you're able to show a book-matched pattern on the ends. The inner part of each end is glued up from the leftover pieces of the 8/4 stock. This is a nice way to keep the legs from appearing as though they were stuck on as an afterthought. Good grain matches on the legs and ends make each assembly look like one solid piece (see drawings, facing page). This is particularly effective if you can choose an 8/4 board that is flatsawn and wide enough for the edges to have growth rings running at about 45° (as seen on the end grain). This gives you straight grain on the legs, which helps disguise the glueline. As a bonus, the adjacent faces of the legs also match each other.

In the mock-up, I resawed the 8/4 stock thin, trying to avoid the green heartwood, but the thickness of the layers doesn't matter. The object is to calculate the width of each end so that little wood is lost between the ends and the legs, which would disturb the grain match. Also, you must start thick with both layers to allow for later milling. Once the inner and outer layers have been edge-glued, skim them with a handplane before gluing them together.

Alignment is much easier if you leave the parts long at this stage. The extra length allows you to nail the parts together in the waste areas when you clamp them up. The laminated parts should be given several days to move and reach equilibrium. After they are done moving, both the leg blanks and the ends can be flattened and thickened at the same time. When you trim the ends to finished length and width, remember to keep the book-match line centered and parallel to the edges.

Dovetailing the case—The top and bottom of the case are milled and glued up like any large panels, then cut to final size. The dovetails that hold the case together are fairly easy to cut, either by hand



THE BASIC CASE

A simple dovetailed box is modified to accommodate the legs. Dovetails can be cut coarse (with wide pins and tails) because the top will cover them. Narrow tails at the front and back of the top and stub tenons at the case bottom are later fitted to the legs.

2. DOVETAILED BOX

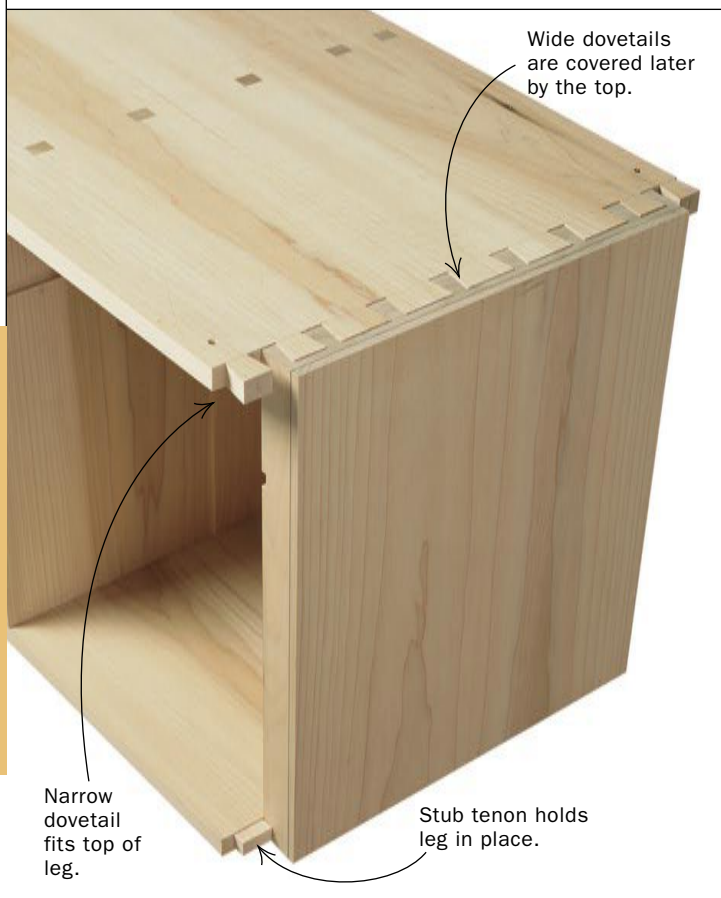

THROUGH-TENONS RESIST RACKING

The partitions are set into stopped dados cut into the top and bottom of the case. Through-tenons on the partitions are housed in mortises cut into the case.

3. PARTITIONS

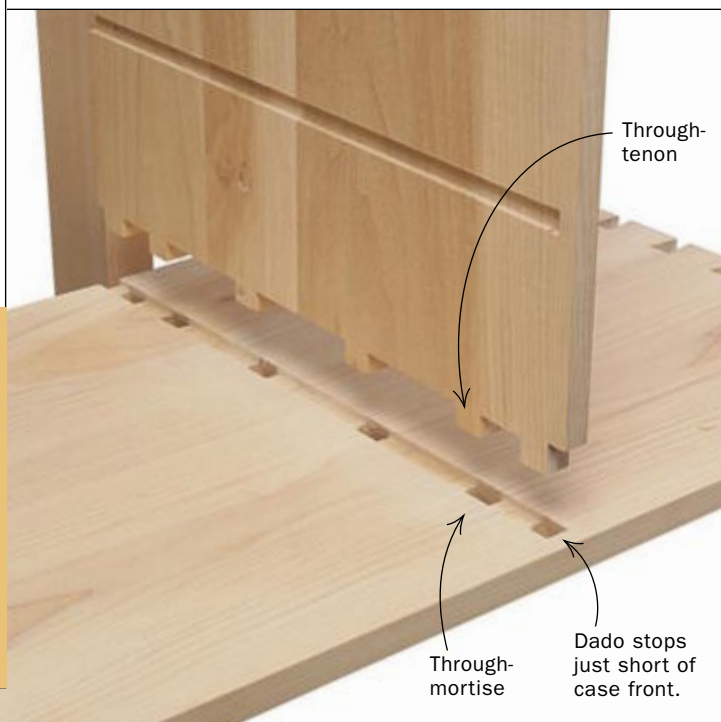

4. DOVETAILED LEGS

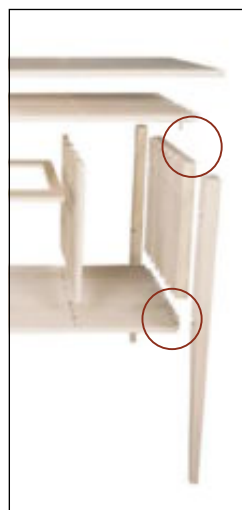

LEGS SLIDE INTO PLACE

By housing each leg in a narrow dovetail at the top of the case and a stub tenon at the bottom, the leg can be slipped into place from underneath after the basic case has been assembled. Stopped dadoes are cut to accept the drawer frames. Cutting the dadoes with ends and legs clamped up before assembly ensures perfect alignment. The exposed top is screwed to the top of the case from underneath.

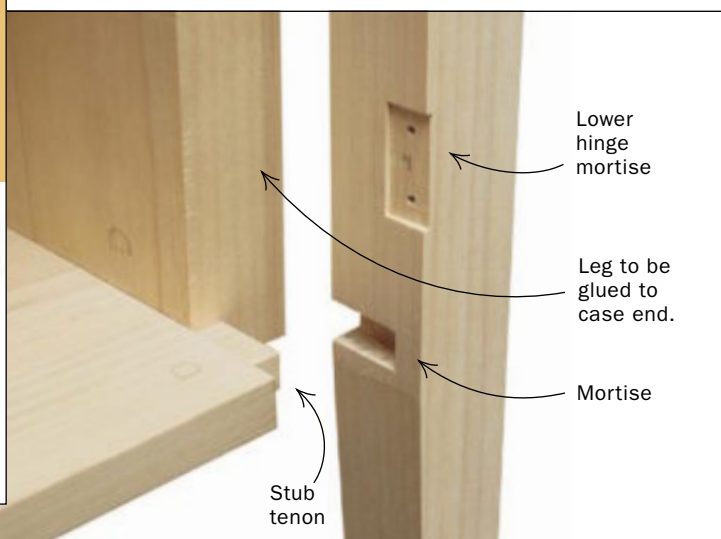
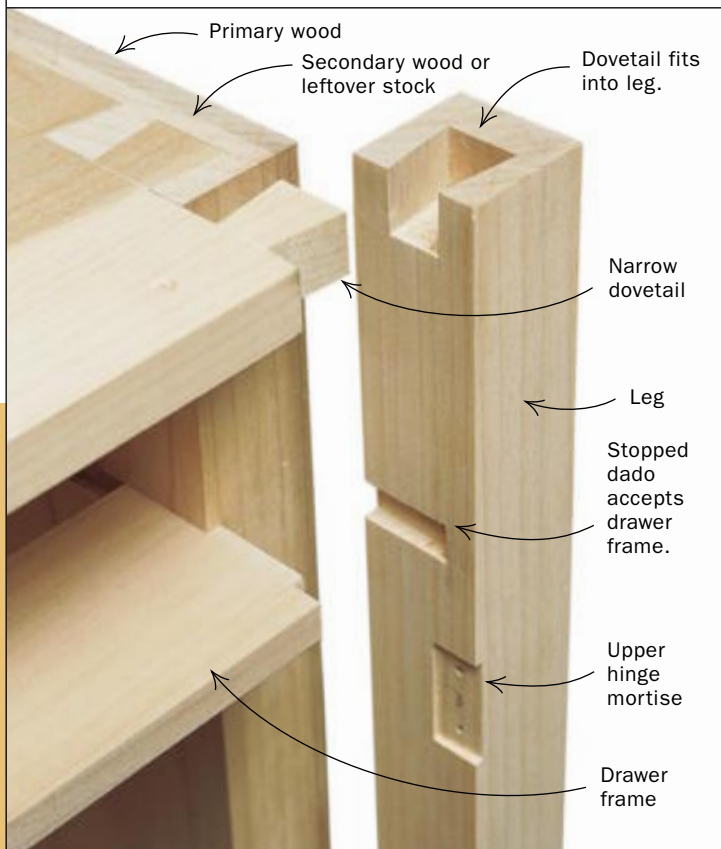

partitions. Tenons are positioned on the partition ends so that there is extra holding power at the edges with enough tenons across the middle to strengthen against racking. The partitions are held in line by the dadoes, which makes fitting the thickness of the partitions to the dadoes careful work. Partitions should be cut a bit longer than the ends to leave some extra tenon length for final flushing.

Because the partitions are fully housed in the dadoes, there are only small shoulders at the front. It is very important that when clamped, the tenon shoulders bottom out in the dadoes, keeping both the top and bottom of the case parallel. So work hard at cleaning up the dadoes to keep them at a consistent depth.

To gauge the front shoulders, work in from both ends with a cutting gauge at the front until what's left between the lines equals the distance between the base of the pins cut on the case ends. Then add the depth of the dado and mark the space between the tenons. The trick is to get the small front shoulder to close at the same time that the end grain between the tenons bottoms out in the dado. This ensures that the top and bottom will remain parallel.

Once the tenons have been cut, locate the mortises in the dadoes. Line up the fronts of the partitions with the front of the case and mark around the tenons to establish your mortises. There is no need to run the tenons through, but it does add strength and keeps you from having to clean the bottoms of the mortises. When the partitions fit squarely into place, you've finished framing the basic case.

Attaching the legs to the case—The legs are mortised to accept the stub tenons cut into the bottom board (see photos, left). Because these tenons and the top dovetails share the same shoulder line, the legs should register flush to the case ends. Once the top dovetails are let into the legs, you can't trim any more wood off the legs and ends, so make sure this joint is accurate before you cut it.

This method puts one serious requirement on the legs. They can be sawn to shape, turned, or carved, but the solid glue surfaces must meet the case ends.

To guarantee alignment, it's best to cut the dadoes for the drawer dividers using a router with the case ends and legs clamped up. Once the stopped dadoes have been cut, the case construction becomes fairly

or machine, but remember that the layout is different at each corner where a leg joins the case (see top photos, p. 73). The top rear dovetails are narrow so there's enough room on the legs to cut the rabbets for the back boards. The case bottom has stub tenons that will be housed in the legs. These tenons are shouldered so that any later sanding won't change the fit of the joints. Once the piece is finished, none of

the joinery will be visible, so the dovetails can be coarse (with wide pins and tails).

Filling out the facade—Interior partitions not only delineate sections, but they also provide strong vertical support to prevent the case top from sagging. The partition joints are somewhat fussy to cut, but they add considerable strength to the case (see bottom photos, p. 73). Shallow stopped dadoes are used to locate the

Details for any style

Proportion and detail can be used to lend a sideboard a period feel. Working out a new design gives you a chance to try some of these possibilities and find a good fit for the design and style ideas of the piece you want to build. The size, shape, and proportions of a piece, along with the choice of materials, finish, hardware, and embellishments, work together to define the style.

The mocked-up sideboard was designed only as a model for construction, but the size and proportions, along with the tapered legs, give it a Shaker feeling. This design could be made of maple or cherry with a simple molding for the doors. I made the storage capacity as large as possible without losing the horizontal effect of the case. The central bay of drawers is wider than the side bays to allow for some larger drawers and because the narrow side bays keep the doors from looking too square. The resulting side bays frame and balance the strongly horizontal case.

Federal sideboards typically rely on large veneered surfaces for decoration. But a simpler, solid-wood construction inspired by the period could be built easily using this construction system (top left). Touches of inlay and the use of simple stringing (inlaid veneer strips) echo the effect of the more complex examples. I would use legs that are either tapered and inlaid or turned below the case bottom. Turned legs could be embellished by reeding the long tapers. The square top section of the legs could have a rectangular panel defined by holly stringing. To maintain the flat appearance of Federal veneered doors, two options come to mind: 1) a solid-wood frame-and-panel door with the panel rabbeted to be flush to the frame or 2) a mitered solid-wood frame with a veneered panel for contrast. A small, curved apron below the bottom edge of the case would soften the shape of the case. The long, slender legs and small case section give the piece a delicate appearance.

A Stickley-influenced, Arts and Crafts sideboard should be heavier looking to emphasize its medieval inspiration (center). I would use oak, fumed or stained to look old. The legs could be thicker to stand proud of the case. The case ends as well as the front framing members would be set back $\frac{1}{8}$ in. to make the construction distinct. The divisions of the front space enhance the overall effect: The doors are square and severe, eliminating any sense of vertical lift. The large drawer at the bottom has a slablike appearance. The entire piece looks solid and heavy.

Also under the umbrella of the Arts-and-Crafts movement is the Greene-and-Greene sideboard (left). The furniture and architecture of Greene and Greene are a bit more refined and softer than Stickley's, with more gentle curves. The piece is strongly horizontal—even the doors are wider than they are tall. You can incorporate these and other details: carved door panels or stepped cloud-lift door rails, ebony splines and details, and bordering surfaces enhanced by setbacks and rounded corners. The overall effect should balance explicit construction with softness in detail.

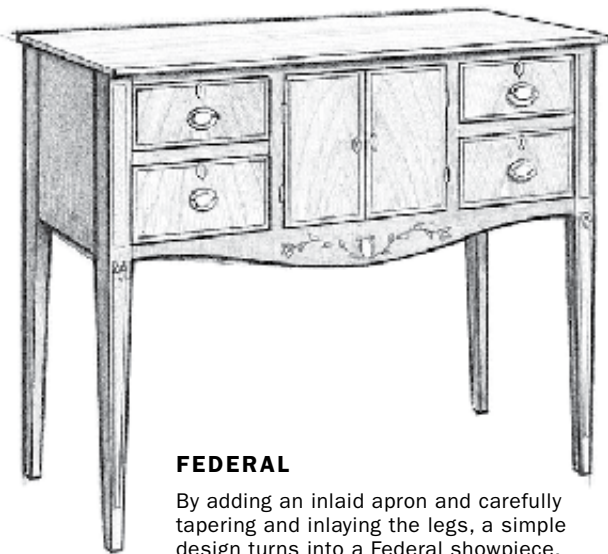

FEDERAL

By adding an inlaid apron and carefully tapering and inlaid the legs, a simple design turns into a Federal showpiece.

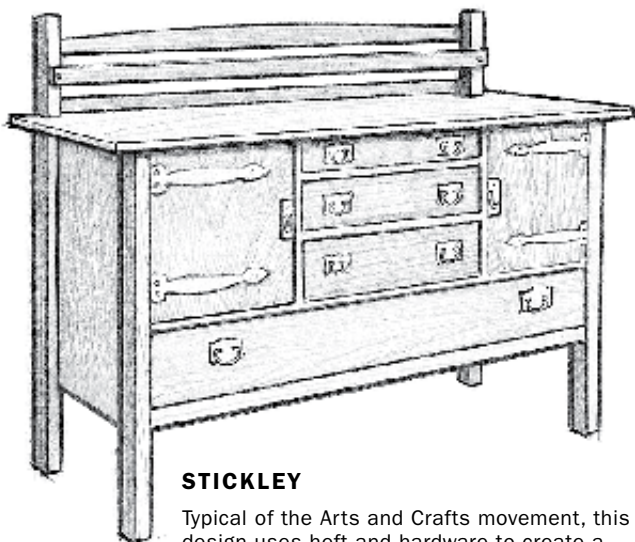

STICKLEY

Typical of the Arts and Crafts movement, this design uses heft and hardware to create a solid sideboard with a medieval inspiration.

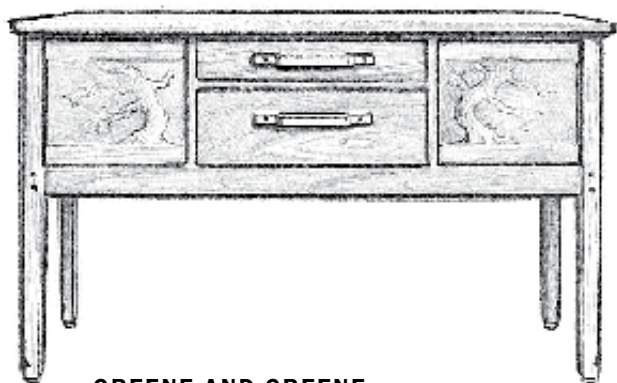

GREENE AND GREENE

Ebony splines, pulls, and pegs, rounded corners, and carefully recessed legs can be used to build a softer Arts and Crafts style.

SIDEBOARD BACK

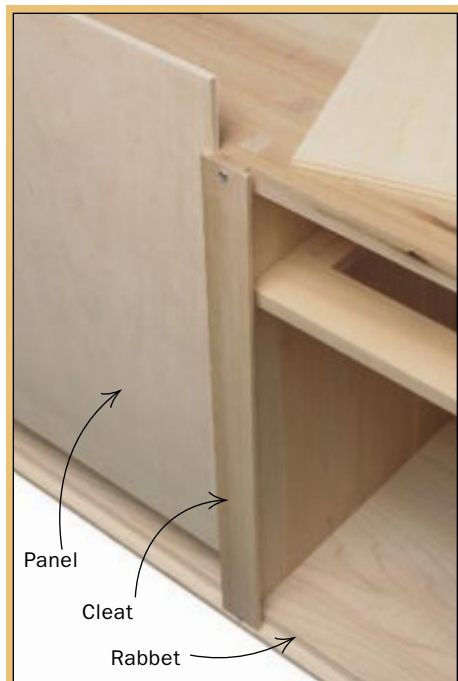

BACK RIDES IN RABBETED CLEATS

Rabbeted cleats are screwed to the rear top and bottom of the case. Three panels of 1/4-in. plywood slide easily into place.

ordinary. Mortise-and-tenon frames that separate the drawers are glued in the front 3 in. or so but not at the back. Leaving space at the back ensures that when the case shrinks, the frames don't push against the back of the case. Both the frame-and-panel doors and the dovetailed drawers are built using the usual methods, but I put small vertical stops behind the doors.

The rear legs and the bottom are rabbeted to accept the back. The back on the mock-up is a series of 1/4-in. panels held by rabbeted cleats attached with screws. The top is ripped even with the bottom of the back rabbets so that the back boards run up to the exposed top. (This is not critical, but it does make it easier to fit the back.) A more elegant solution would be to resaw thin shiplap boards and run them vertically across the back. The top can be cut to allow some overhang, then molded and screwed down from below.

Alternative constructions

There are a number of places where construction can be altered to save wood or to produce a slightly different effect. People are often surprised by the use

of a full-board top and bottom. While it does use extra wood, it also adds strength to the case, resists cupping at the ends, and provides built-in kickers for the top drawers.

As a substitute, you could use two wide rails, with gussets or without. If your design has no cupboard space, you could use similar rails at the bottom. To allow for wood shrinkage, remember to fit any kickers with gaps at the shoulders and leave the rear tenons unglued.

The case ends could also be thinner than the legs, creating either a reveal where the ends join the legs or a recessed nook inside the case. Because of the added complexity of the case dovetails and drawer frames in the latter option, I would use it only if saving weight or wood is an issue.

It's easy to add decorative aprons between the legs (see the bottom drawing at right). At the lamination stage of making the case ends, glue on the outer layer

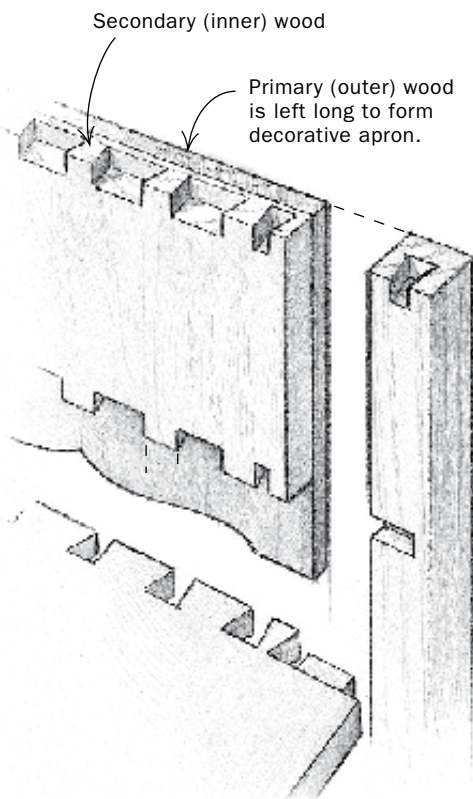

DECORATIVE APRON ADDS TO DESIGN

Cut the primary wood long and glue it to the secondary wood to form an apron that can be accented with scrollwork inlay. Cutting the secondary wood shorter allows you to employ the construction methods used on the basic case.

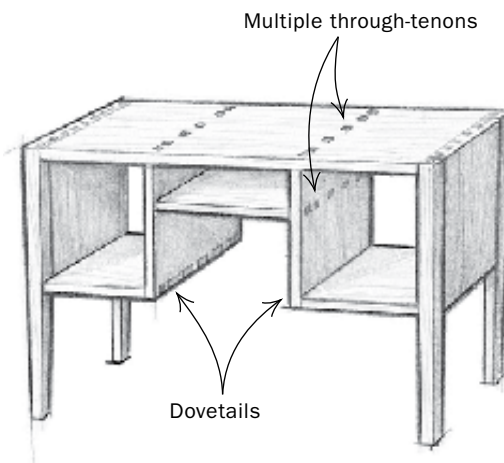

RAISE THE CENTER SECTION

No matter how you change the design, the rules of construction are simple—dovetail joinery is used at all corners, and multiple through-tenons are used where a board joins another along its length.

long at the bottom. This creates a large lap for the dovetails, which, as before, are cut flush on the inner layer of the end. The outer layer hangs down and can be sawn to shape. To add an apron across the front, the bottom can be cut back and an apron piece glued onto the edge of the bottom. If the apron is wide at the center, it can be braced from behind. If it is wide at the leg, it should be tenoned into the leg to prevent racking and twisting.

The most common change to the case is to have the bottom step up in the middle. This introduces movement, breaks up the strongly horizontal case, and allows different ways of arranging the doors and drawers. This type of case construction is more complex, but it uses the same joints as before (see top drawing, right). Just remember how this system works: If a case part joins another at a corner, dovetail it; if a part meets along another's length, use multiple tenons. When you add a step up in the center of the case, only the fitting sequence changes.

First, cut and fit the multiple stub-tenon joints between the inner verticals and center bottom panel. All of the stub tenons can be cut at the same time, but put off dadoing the top until the center panel is in place. The important thing here is to keep the inner verticals parallel. If the center panel clamps up shorter than planned, it's easier to move the dadoes in the top board (and make the center section smaller) than

Finding the right proportions

With a sideboard, as the case gets larger and the negative space between the legs grows smaller, the piece begins to look more massive. But take a look and compare cases 1 and 2. Case 1 is far more delicate in size, but the case divisions give a static effect because they are based on squares and rectangles. Although case 2 is much bigger, both the vertical rectangles of the doors and the graduated drawer sizes help relieve any sense of heaviness. What if the drawers were the same size and the doors more square?

Putting the doors on the outer parts of case 3 leaves the drawer compartment overpowered, at least to my eye. Even though the initial placement of the partition gives equal divisions, once the central space is divided, it looks small.

Case 4 uses proportions that I often rely on. Making drawers in the middle wider than the doors gives the facade a strong impression but is not as obvious to the eye as dividing the facade elements evenly. Dividing the total sideboard height in half is also satisfying but remarkably subtle because it takes a moment to see the relationship of the positive space to the negative. Overall, I like the interplay of vertical and horizontal rectangular spaces. But I would still be willing to adjust things by eye to get a more pleasant drawer spacing, for instance. For me, it's less important that the height be exactly divided in half than it is for the divisions of space to produce an impression of these proportions.

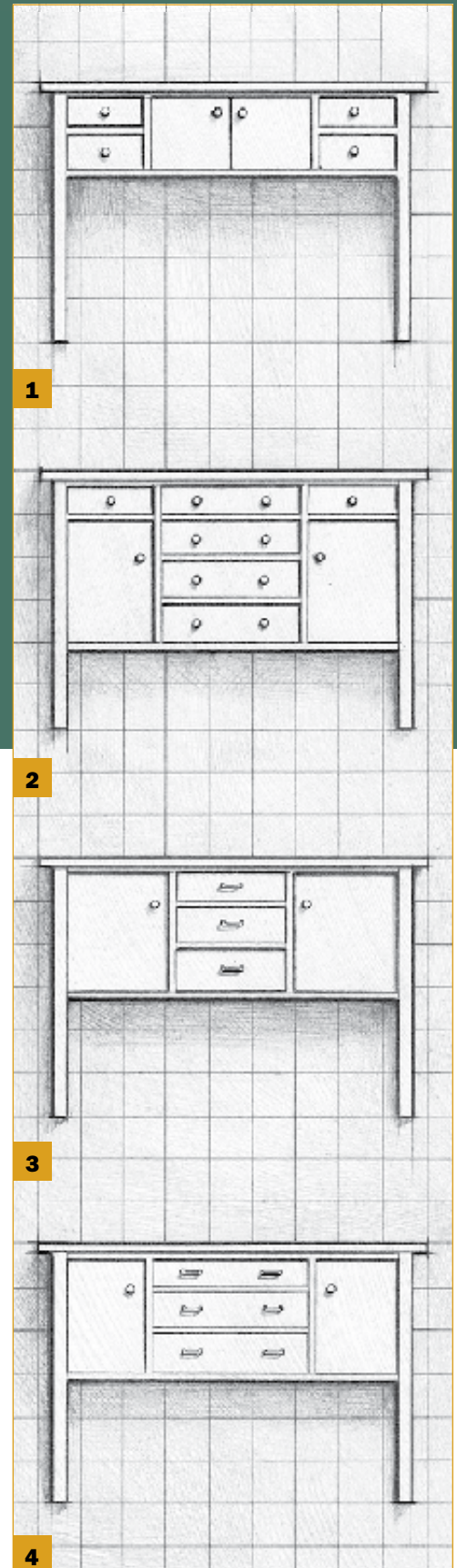

it is to live with verticals that aren't perpendicular to the case.

Now, fit the dovetails of the ends to the top. While cutting the outer bottom panels, you can make any necessary adjustments. The most important thing is to keep the verticals parallel. Many things can creep in to change the exact locations of the verticals, but the top now tells you the actual distance between the inside faces of the verticals, a measurement that is more important than the overall length of the bottom pieces. So if the bottom location changed or you cut the bottom a bit short, adjust the gauge line for the dovetails until the distance between them is the amount required. The slight change of length in the tails is absorbed in the lap of the pin piece. As before, the space below the raised center section can be filled with decorative apron pieces.

Proportions and style

In designing a sideboard, it's important to consider the visual effect that the proportions and construction methods will have, then choose ones that help express the

intent of the design. Before considering any decorative effects, sketch a few cases of different sizes and proportions (see the story above). Then use tracing paper to try out a variety of partition locations and to vary the door and drawer sizes. This exercise gives you a sense of how changes in proportion alter the effect. You may find yourself discarding all of these sketches, preferring to develop a second set using your eye to judge correctness.

The methods used on the mocked-up sideboard should provide the basics of construction. More complex cases are possible, but they are all offshoots of this basic method. You can choose details to design a sideboard with a refined period look, or opt for something more contemporary. Most alternative designs don't really change the construction methods much. They are additions to the basic case that either save wood or provide surfaces for design options. □

Will Neptune is a furniture maker in Acton, Mass., and a former woodworking instructor at North Bennet Street School in Boston.

Illustrated Guide to Drawers

From simple to refined, drawer options for the furniture maker

BY MATTHEW TEAGUE

Whether it's a tiny drawer in a jewelry box or the wide, deep drawer of a dresser, all drawers are little more than a box that slides into an opening. There are nearly endless combinations of construction methods that can be used to build that box, but a few stand out as the best blends of beauty, strength, and efficiency.

Drawers can be made of solid wood, plywood, or a mix of both. Drawer fronts often become the focal points of a piece, showing off spectacular figure in a board or sheet of veneer. They can be flush to, recessed into, or overlapping the front of the case, and they can be decorated using beads or profiles. Corner joinery, at both the back and front of the drawer, can range from simple butt joints to variably spaced dovetails. Drawer bottoms can be made from solid wood or plywood.

The drawer joinery and materials you choose should fit the type of furniture you want to build—quick-to-make joints and inexpensive materials for drawers in a utility cabinet, finely crafted joints and quality materials for drawers destined for an heirloom piece. Regardless, when it comes to building a drawer, the most important joint is the one that connects the sides to the front.

Strong joinery ensures long drawer life

Most stresses on a drawer occur at the front corners—after all, a drawer is opened by pulling on the front. Any action that isn't straight in or out of the drawer pocket also causes racking stress, which hits the front-



The ideal drawer

As you can see, there are a number of great ways to build a drawer. A utility or light-duty drawer (top) might be a simple combination of a pinned rabbet joint at the front, a back that's dadoed into the sides, and a plywood bottom. A high-end drawer (bottom) could have hand-cut half-blind dovetails at the front, through-dovetails at the back, and an elegant raised-panel, solid-wood bottom. And sliding dovetail joints (middle) fall somewhere in between. Read on to learn how to balance elegance and efficiency for the job at hand.

Front-corner joints

The joinery at the front corners of a drawer determines the overall look and often differs from the joinery at the rear corners. Below are nine common methods used to connect the front of a drawer to the sides. Whether you're looking for a quick joint that gets the job done or a long-lasting, hand-cut detail, there's a joinery option to fit your tastes, needs, and skills.

Rabbet should be half to two-thirds as thick as the drawer front.

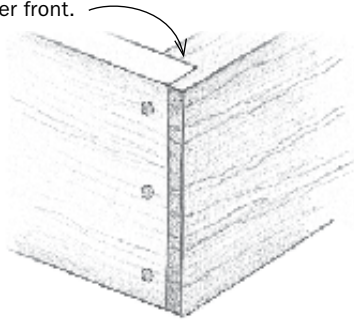

PINNED RABBET

The rabbet is easy to make, but it's not very strong. It should be reinforced with some kind of fastener, such as recessed screws, cut copper nails, or wooden dowels or pegs, which offer a clean, handmade look.

Pins hold joint secure against pulling forces.

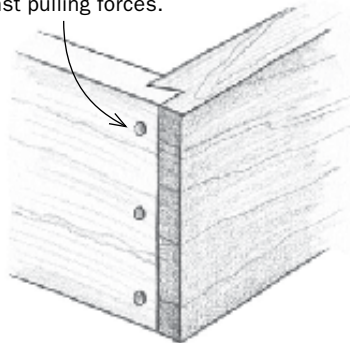

DOVETAILED RABBET

A dovetailed rabbet is stronger and more attractive than a simple rabbet joint. This type of corner joint also should be reinforced with pegs, brads, or some kind of mechanical fastener.

Tongue adds mechanical strength to resist pulling forces.

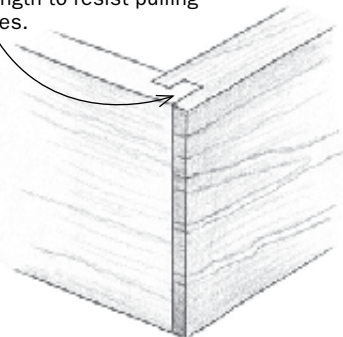

TONGUE AND RABBET

Though it takes a few more tool setups, a half-blind tongue and rabbet adds built-in mechanical strength to the joint. For this reason, it's usually not necessary to reinforce this joint.

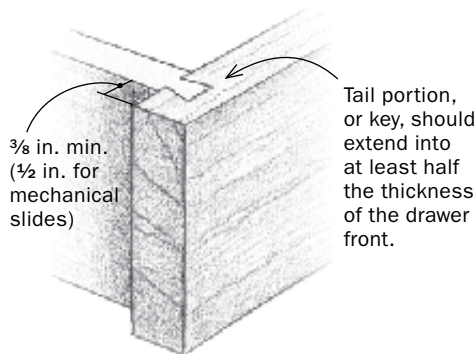

3/8 in. min. (1/2 in. for mechanical slides)

Tail portion, or key, should extend into at least half the thickness of the drawer front.

SLIDING DOVETAIL

Sliding dovetails are a quick, strong joinery option and often are used on drawers designed with overlay fronts and on flush drawers that use mechanical slides.

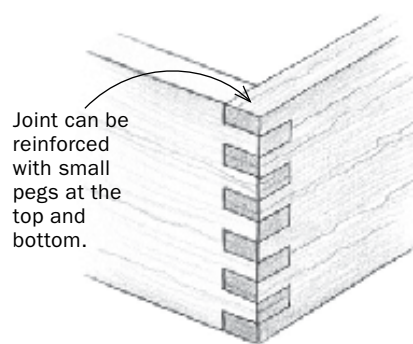

Joint can be reinforced with small pegs at the top and bottom.

FINGER JOINT

The finger joint has a series of narrow knuckles that lace together and offer plenty of long-grain glue surfaces. Because the tool setups are the same, if you use finger joints at the front of a drawer, use them at the back, too.

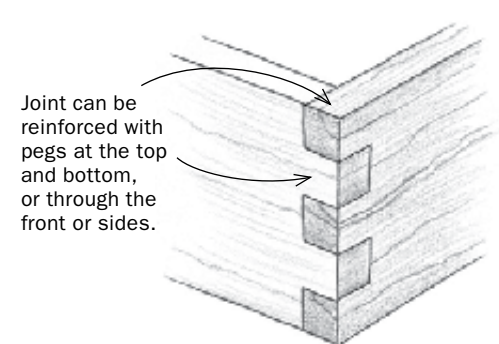

Joint can be reinforced with pegs at the top and bottom, or through the front or sides.

BOX JOINT

The box joint is the beefier cousin of the finger joint. If you're using box joints at the front of a drawer, it's efficient to use them at the back, too, because tool setups are identical.

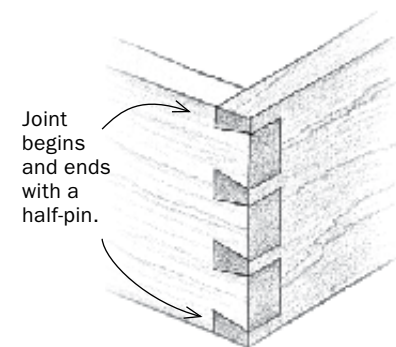

Joint begins and ends with a half-pin.

THROUGH-DOVETAIL

If you like the look of exposed joinery, the angled tails and pins of a through-dovetail create a secure joint that resists pulling and racking forces. Through-dovetails also can be used at the back of a drawer.

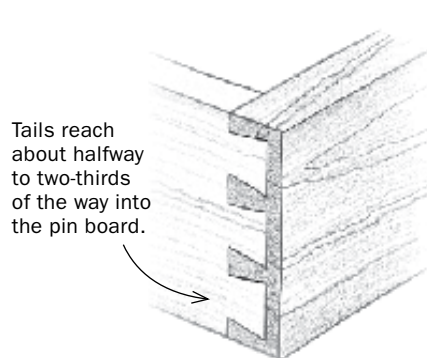

Tails reach about halfway to two-thirds of the way into the pin board.

HALF-BLIND DOVETAIL

Many regard the half-blind version as the king of dovetail joints. For concealed joinery with superior strength, half-blinds are a good choice.

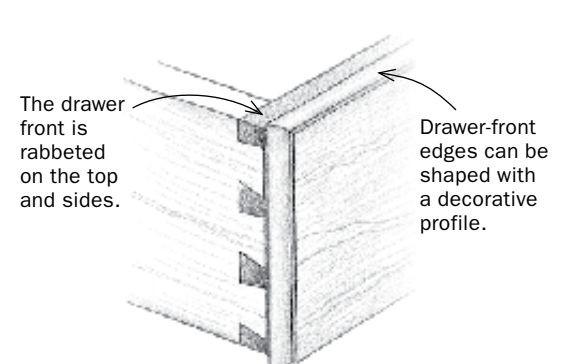

The drawer front is rabbeted on the top and sides.

Drawer-front edges can be shaped with a decorative profile.

LIPPED HALF-BLIND DOVETAIL

For overlay drawers with excellent strength, use lipped half-blind dovetails. With this joint, the front is rabbeted and joined to the sides with dovetails.

corner joints hardest. For these reasons, front-corner joints should be as strong as possible and have some mechanical reinforcement. This mechanical connection can be as simple as pegs or pins in a rabbet joint, or it can be the interlocking strength of the classic half-blind dovetail (see sampling of joints on p. 79).

At the back corners of a drawer, aesthetics are less of a concern because these corners are rarely seen. Even though the back corners suffer less racking and stress than the front corners, you still want to choose a sound mechanical joint. Often, the rear-corner joints are different from the front-corner joints. If you are using a machine setup to cut the front joinery, however, it makes sense to use those same setups to cut the back joinery. Some rear-joint options, such as the dado and the sliding dovetail, allow you to create a drawer with built-in full-extension slides so you have access to the entire depth of the drawer.

Drawer bottoms: Fancy or functional

As with the corner joinery, the choice of material and design for the drawer bottom depends on the style of drawer you are building—whether it's a quick-and-dirty shop drawer or a drawer for a high-style reproduction secretary.

Solid wood and plywood are commonly used for drawer bottoms. Solid wood is the traditional choice, and aesthetically, it's hard to beat. But you must allow solid wood to expand and contract with changes in humidity. In most cases, solid bottoms are either raised or rabbeted to fit grooves in the drawer sides and front. Align the grain so that movement occurs front to back; doing otherwise could cause the drawer to bind. Typically, the bottom slides in from the rear and is screwed to the back via a slotted hole that allows the bottom to move without cracking.

Plywood is a much more stable choice for a drawer bottom because it does not expand and contract with humidity changes as much as solid wood. Though reproduction builders and a few purists resist using plywood bottoms, it's easy to argue their superiority. A plywood bottom can be housed in grooves in the sides, back, and front, or it can be slid in from the rear and screwed to the drawer back. □

Matthew Teague is a writer and woodworker in Nashville, Tenn.

Rear-corner joints

For both aesthetic and structural reasons, the back corners of drawers need not be joined in the same fashion as the fronts: The rear corners are less visible than the front corners and suffer less racking and stress during use.

To avoid interfering with the action of the drawer, any reinforcing fasteners must be flush or slightly countersunk on the drawer sides.

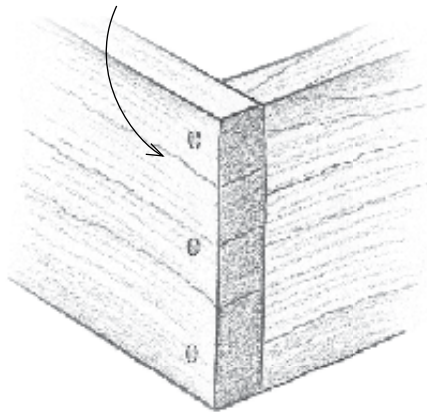

BUTT JOINT

Because the joint itself is seldom seen, a simple nailed or pegged butt joint is sometimes used at the back of drawers that see only light use. Adding biscuits is a good way to strengthen this otherwise rudimentary joint.

½ in. extra length at back

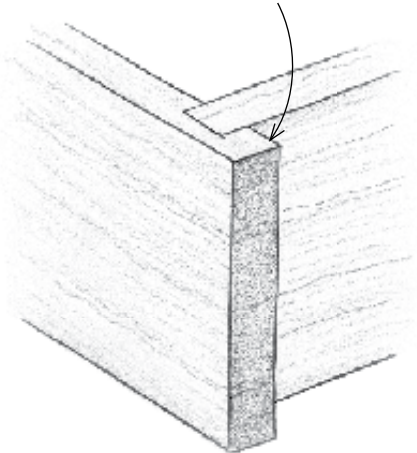

DADO

A simple dado cut in the drawer sides is an easy and effective means of attaching the back to the sides. When using a dado at the back, you can leave the sides long, creating in essence full-extension slides that will give you access to the full depth of the drawer when it is opened.

Shoulder helps keep the drawer square.

½ in. extra length at back

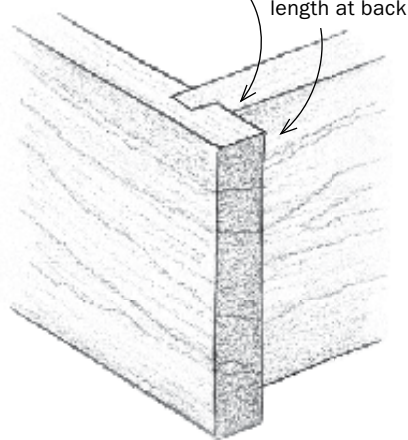

DADOED RABBET

The dadoed rabbet helps keep the drawer square and is easier to fit than a simple dado. You rabbet the back to fit the dado, as opposed to trying to match the dado width to the thickness of the back. Leaving the sides long at the back will give you access to the full depth of the drawer when it's open.

Key should extend into at least half the thickness of the drawer side.

½ in. extra length at back

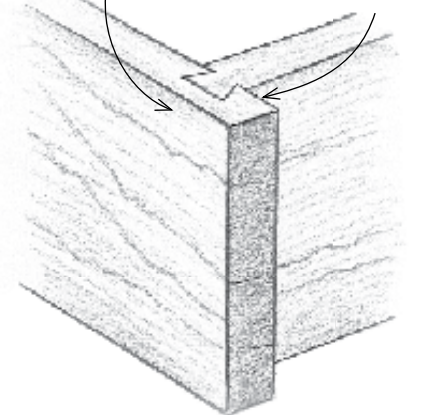

SLIDING DOVETAIL

The sliding dovetail has built-in mechanical strength (instead of glue alone) to help hold the joint tightly. As with the dado (above), leaving the sides long at the back will give you access to the full depth of the drawer when it's open.

Drawer bottoms

Solid wood and plywood are the most common materials used for drawer bottoms. A solid-wood panel will expand and contract with humidity changes, so it must be sized and installed to allow for that movement. A plywood bottom offers a more stable (and simple) option, but traditionalists see it as thin and bland.

THREE EDGE PROFILES FOR A WOOD BOTTOM

BEVEL EDGE

A bevel edge can bind or rattle in its groove because it doesn't sit on the groove bottom. The extra thickness in the middle allows the bottom to carry a heavier load.

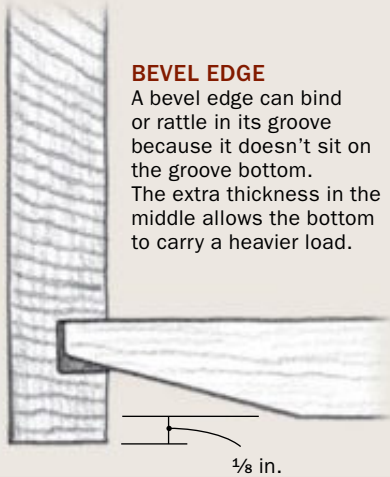

RAISED PANEL

A raised panel creates a flat on the edge for a better fit in the groove. The flat is usually cut using a router or shaper. The raised area provides a traditional look, and the extra thickness in the middle allows the bottom to carry a heavier load.

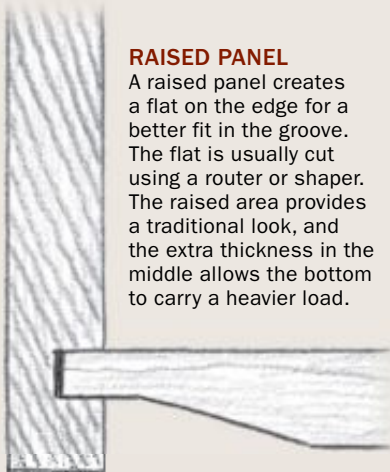

RABBETED

The extra thickness of the bottom offers the same strength as a beveled or raised panel. Aligning the rabbeted edge parallel to the drawer parts makes squaring the drawer easier during assembly.

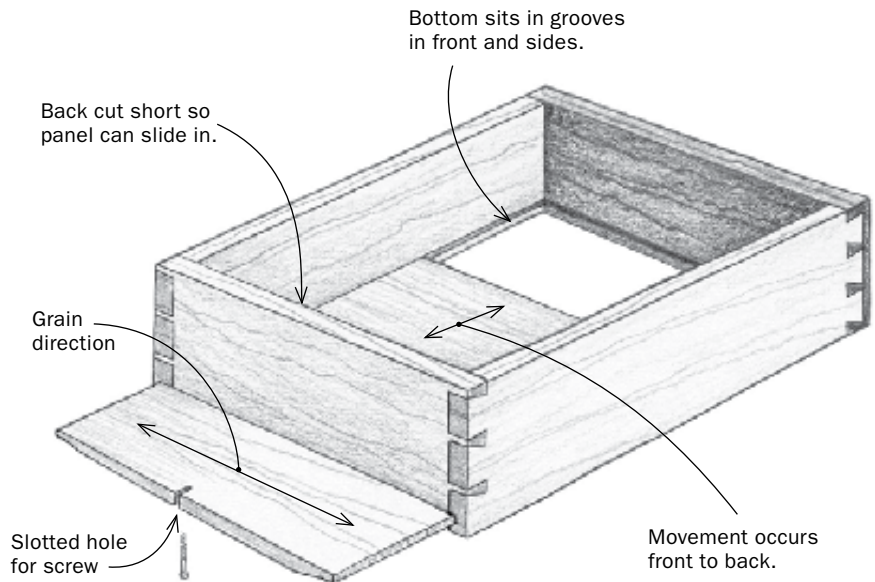
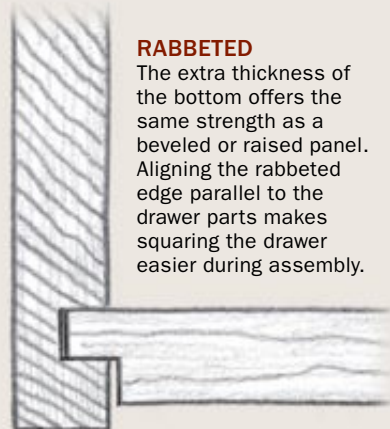

SOLID-WOOD BOTTOM

Traditionally, solid-wood panels slide into place after the sides, front, and back of the drawer have been assembled. The back is cut shorter, allowing you to slide the bottom in place, and the bottom is screwed to the back through an elongated hole to allow for wood movement. Building a drawer in this way allows you to take it apart for repairs.

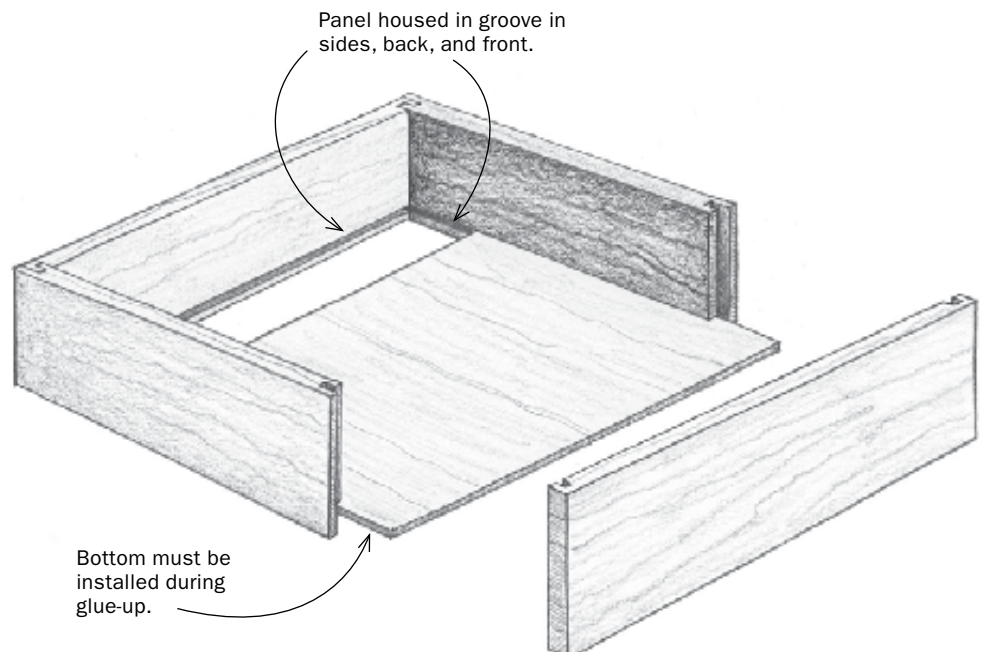

PLYWOOD BOTTOM

Though reproduction builders and a few purists look down their noses at plywood drawer bottoms, they are more stable than solid wood and have great strength. A 1/4-in.-thick plywood bottom can carry all but the heaviest loads. Plywood bottoms can be slipped in after assembly, just like solid-wood bottoms, or fully housed in grooves, as shown above.

The Dovetailed Drawer

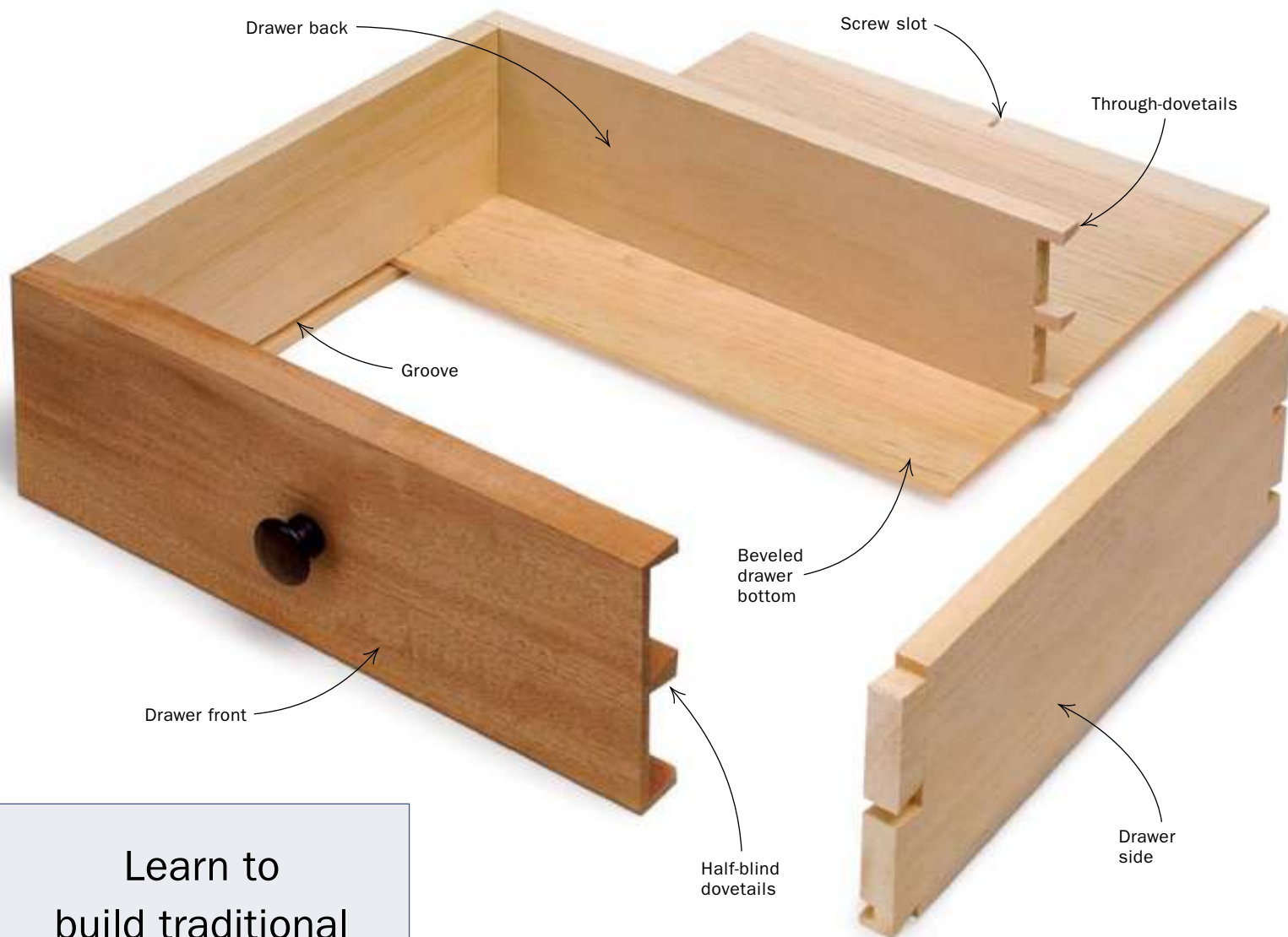

Learn to
build traditional
drawers that
stand the test
of time

**BY JANET A.
COLLINS**

The dovetailed drawer has long been the hallmark of quality, hand-crafted furniture. And for good reason: A dovetailed drawer is both beautiful to look at and strong enough to last 200 years. But dovetailing a drawer is not the daunting task you might think—all it requires is a little know-how and practice. No matter what size drawer you're building or what piece of furniture it's going into, the techniques are the same. If you can build a

drawer for a simple Shaker table, you can build a dozen of them for an 18th-century highboy.

The key to building a drawer is learning to cut dovetails. A traditional dovetailed drawer combines both half-blind and through-dovetails. Because you want to see dovetails only on the drawer sides, use half-blind dovetails at the front of the drawer. Through-dovetails are used to connect the back to the sides. In this article,

I'll walk you through cutting the half-blind and through-dovetail joints typical in traditional drawers. I'll focus mainly on cutting half-blind dovetails, because once you learn to cut those, through-dovetails become a piece of cake.

I teach a three-day workshop on cutting half-blind and through-dovetails. In that class, students not only learn how to lay out and cut these two joints, but also how to build a traditional dovetailed drawer. The first order of business is to tune up your tools: two chisels, a dovetail saw, and a marking gauge. Using properly tuned tools makes your woodworking life much easier.

As you're working, remember to cut pins on the drawer front and back and tails on the drawer sides. Dovetails go together and come apart only one way, and this orientation works with the movement of the drawer being opened—you won't loosen the joint as you open and close the drawer.

Build drawers to fit the case

Before you start building drawers, your table or case piece should be constructed and glued up, and the drawer parts should be milled to finished thickness. Drawer fronts should be $\frac{3}{4}$ in. to $\frac{7}{8}$ in. thick; sides and back should be $\frac{3}{8}$ in. to $\frac{1}{2}$ in. thick.

Now cut drawer parts to length and width based on the opening in the case piece or table. For a flush drawer, rip the fronts and sides approximately $\frac{1}{64}$ in. smaller than the height of the opening. To accommodate the bottom, cut the drawer back $\frac{1}{2}$ in. narrower than the sides. Then mark the lengths directly off the case piece and crosscut them to size at the tablesaw. The length of the sides should be approximately $\frac{1}{2}$ in. shorter than the depth of the drawer opening in the case.

Now you need to decide which will be the inside and outside faces of each drawer part. If you place the heart side of the board facing out, the drawer parts will cup toward the inside. The mechanics of the joint will help control this cupping. However, aesthetics rule—especially on the drawer front. If the bark side is more attractive, place that side out.

With all of the pieces marked, cut grooves along the lower edge of the front and sides. The $\frac{1}{4}$ -in.-wide by $\frac{1}{4}$ -in.-deep grooves should be $\frac{1}{4}$ in. up from the bottom on the inside of the drawer front and



FIT THE DRAWER TO THE OPENING

Measure the drawer parts straight off the case. Cut the sides about $\frac{1}{64}$ in. shy of the height of the drawer opening (left). Trim the drawer front for an even reveal at the top, bottom, and sides (below).



sides. This can be done with a dado set on the tablesaw or with straight bits on the router table. Once the grooves have been cut, you can start marking the parts.

The shoulder lines of the dovetails are based on the thickness of each part, which changes slightly in final preparation. Be sure to plane, scrape, or sand (to P220 grit) the drawer parts before laying out and cutting any dovetails. Once you've removed the machine mill marks, organize and label all the drawer parts. Mark the inside face

and adjacent drawer-bottom edge of the front, sides, and backs. Mock up or explode the box and mark adjacent corners to be dovetailed. You will be checking for this orientation and the reference marks as you lay out and cut the dovetails.

Cut the pins first

Because half-blind dovetails are slightly more difficult to cut than through-dovetails, I'll focus on cutting the half-blind dovetails at the front of the drawer. But the same

HALF-BLIND DOVETAILS JOIN THE FRONT TO THE SIDES

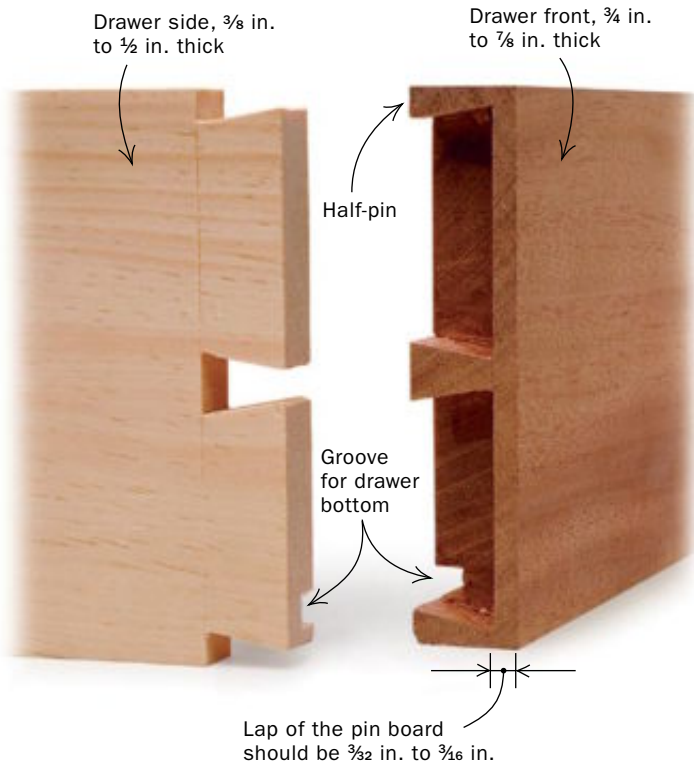

1 LAY OUT AND CUT THE PINS



Lay out the depth of the tails. Mark the lap where the drawer side joins the drawer front. Leave between $\frac{3}{32}$ in. and $\frac{3}{16}$ in. of material so that the tails are hidden when the drawer is closed.



Mark the angled pins. Set a bevel gauge to the desired angle to guide your pencil. The first and last are half-pins; any others are equally spaced between them.

SETTING THE BEVEL-GAUGE ANGLE

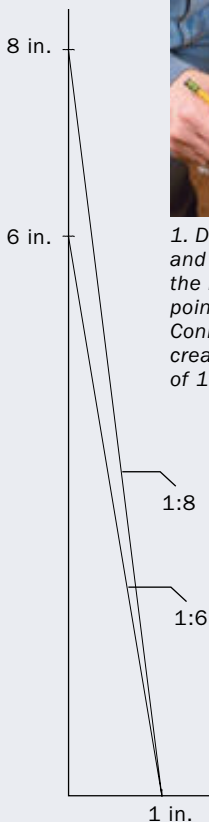

1. Draw tick marks 6 in. and 8 in. from the end of the board. Next, mark a point 1 in. from the edge. Connect these points to create angles with ratios of 1:6 and 1:8.



2. Set the bevel gauge against the board and adjust to the desired angle.

principles apply. There is much debate over whether to cut the pins or the tails first, but I always cut the pins first. I find it is easier to square up the surfaces of the pins and use them to scribe the tails, rather than the other way around.

Shoulder lines are the first layout marks placed on each piece and reflect the thickness of the piece being dovetailed into it. Set a marking gauge to the exact thickness of the sides and scribe a shoulder line on all four edges of each end of the back. If the sides are the same thickness as the back, scribe the ends of the sides with the same gauge setting. If the sides are not the same thickness as the back, reset the gauge and scribe the shoulder lines to the thickness of the drawer back. By setting the gauge to the exact thickness of the pieces and cutting accurately, you eliminate a fair amount of hand-planing and sanding.

The lap of the pin board (drawer front) should be $\frac{3}{32}$ in. to $\frac{3}{16}$ in. A lap thinner than that can be weak and may break when you chop between

pins. Remember to use the inside face of the drawer as your reference face. If the drawer front is $\frac{3}{4}$ in. thick, set the marking gauge to $\frac{9}{16}$ in., leaving a $\frac{3}{16}$ -in. lap.

Set the marking gauge to scribe a line in the end of the board. Be sure to leave $\frac{3}{32}$ in. to $\frac{3}{16}$ in. as the lap. Scribe the ends of the drawer front as well as all sides of the ends of the tail boards. Change the marking gauge to match the thickness of the tail board and scribe this line only on the inside face of the pin board.

Place the pin board in the vise with the inside surface facing you. Doing it this way consistently helps ensure that you orient the pins correctly over and over again. To help students orient the pins correctly, I tell them to remember “fat side or wide side, inside.” Mark the angle of the pin on the end grain with the widest part of the dovetail on the inside of the drawer. To save yourself work later when you’re chopping out the tails, make sure your pins are only as narrow as the thinnest chisel you own.

For both through- and half-blind dovetails, both edges of the pin board should have what are called half-pins. These half-pins can be up to the same width as the full pins but have the angle on only one



Continue the lines around the corner. Use a square to mark out the pins to a shoulder line that represents the thickness of the drawer side. Mark areas to be removed with an X.



Follow the lines. To cut out the area between the pins, use a fine dovetail saw (15 tpi or more) and cut to both lines.

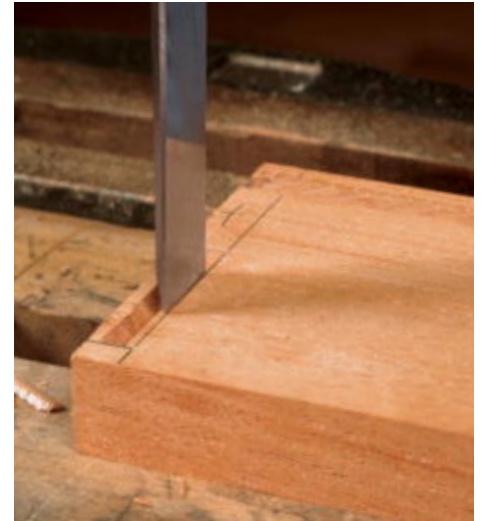

Chop out the pins. Begin by chopping down just inside the shoulder line, then chip away the stock with horizontal blows. Pare to the shoulder line and clean up the sides.

2 SCRIBE AND CUT THE TAILS

side. The half-pins help keep the edges of the tail board from cupping. Space the pins by measuring and dividing the board evenly. My way is quick and simple. I use the width of my index and middle fingers to mark the space between the centers of the pins. These marks are made on the inside edge. Then I mark $\frac{3}{16}$ in. to each side of the center mark of each pin, to end up with pins that are $\frac{3}{8}$ in. wide (fat side).

Use a bevel gauge to draw the angle on the end grain for each pin. The angle should be approximately a 1:6 to 1:8 ratio. Use a square to connect the line and continue it down the shoulder line. The angle line and this square line are the only two lines you need to cut the pins (or tails).

Mark the area to be removed with an X and use a fine dovetail saw (15 tpi or more) to cut to the line. Saw the pins, making sure not to cut into the lap or the inside of the drawer. Chop out the cheeks of the pins that cannot be cut with the saw. Clamp the pin board inside-face up to the workbench. Start away from the shoulder line and alternate chisel blows between horizontal and vertical. Do not undercut the lap or shoulder too much. Place the board back in the vise and pare (trim) the cheeks. Use the back of the chisel to



Mark out the tails. Place the drawer side flat on the bench and clamp the drawer front at a right angle. With the end of the side flush to the end of the lap, mark the tails using a sharp pencil.

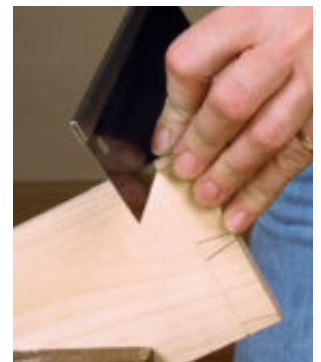

Saw away what you can. The edges of the sides can be cut close to the line. Pare away what little is left using a sharp chisel, and chop out the area between the tails just as you chopped out the waste between the pins.

THROUGH-DOVETAILS JOIN THE BACK AND SIDES

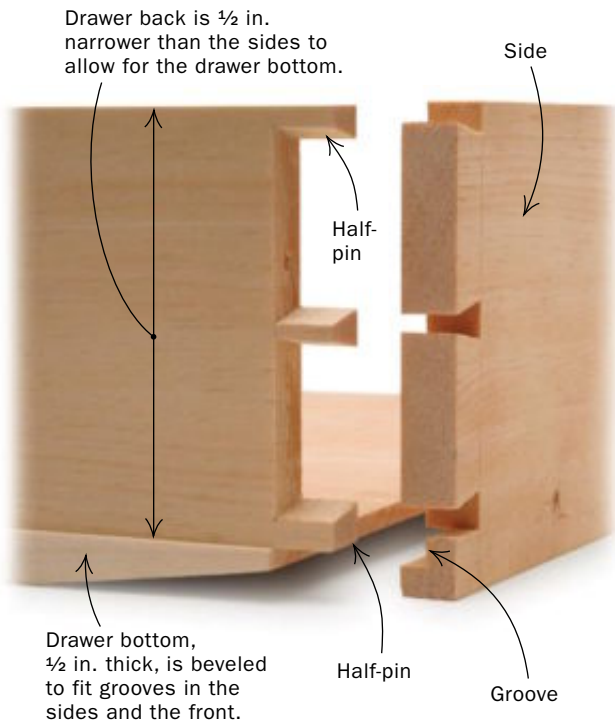

There's no need to angle the saw. When cutting the pins for through-dovetails, you can cut all the way to the shoulder line.

follow both the angled line and the square line to bring the entire cheek of the pin into square. Use a combination square to check that the pin edges and shoulders are square.

Scribe tails from pins, then cut away the waste—The tails are scribed off the pins only after you are satisfied that all of the pins are square. Place the tail board inside-face up on the bench. Clamp the pin board 90° to the face of the tail board, just as if the drawer were going together. Line up the inside face of the pin board directly on the inside edge of the tail-board shoulder line. Scribe the tails using a sharp, hard-lead drafting pencil, which leaves a thin, definite line.

Place the tail board in the vise with the inside facing you. Draw a square line across the end grain from the end of each angled line. Remember that the angle of the pins appears on the end grain and that the angle of the tails appears on the face of the board. Mark the waste with an X and cut to the pencil line, not into it. If you cut beyond the pencil line you will have a gap. Chop out the waste as you did for the pins, but stop at half depth and flip over the board. Repeat the process on the other side and check to see that everything is square.

At this point, your dovetails should start to fit together. If they are a little snug, pare only the tails. Once you have squared the pins, they should not be touched again.

Cut the through-dovetails

Through-dovetails join the drawer sides to the back. Lay out the pins using the same technique described for the half-blind dovetails, but you don't have to leave room for the lap. Once the pins have been cut, chop out the waste halfway through the pin board's thickness, leaving some material to support the end. Then pare to the shoulder line. Flip over the piece, continue to chop out waste, and then pare to the shoulder line. Place the piece back in the vise and pare the cheeks square. This area can be slightly undercut in the center. Tails are marked and cut exactly the same as they are on the half-blind dovetails.

Glue up the drawer and slide the bottom in place

Now, when you assemble the dovetails, you have four pieces of wood that are starting to resemble a drawer. At this point,



Through-dovetails go all the way through. To mark out the tails, clamp the back at a right angle to the side. Because the tails go completely through, make sure the back and side are flush.

GLUING AND CLAMPING



Glue blocks fit the tails. Use clamping blocks made of the same species as the drawer sides (or a softer wood). Be sure to remove any material that might crush the pins. Taping the blocks in place helps ease assembly.

Check for square. Once the clamps are in place, check the diagonals to see whether the drawer is square.



you can glue up the drawer, making sure that it is kept square while you clamp it.

A traditional dovetailed drawer uses a solid-wood bottom. The grain of the drawer bottom should run side to side, allowing it to expand and contract from front to back. Edge-gluе enough $\frac{3}{8}$ -in.-thick stock to equal the drawer depth. Cut these panels $\frac{1}{16}$ in. smaller than the dimension of the drawer and the bottom of the grooves. Bevel the bottom of the drawer. I

typically use the tablesaw to cut this bevel and handplane the bottom to fit. The bottom should fit the groove so that it slides easily but not be so loose that it rattles. Finally, cut a slot (a $\frac{1}{8}$ -in.-wide sawblade kerf) in the back edge of the bottom to screw the bottom to the drawer back. The slot should be long enough to allow the bottom to expand and contract freely.

For the final drawer fitting, lightly plane the sides to fit the case. If the drawer needs

some height shaved off, take it off the top of the drawer, leaving your flat (reference) edge alone on the drawer bottom.

I usually finish the inside of the drawers and the case itself with shellac. Oil finish inside a case takes longer to cure, usually smells for a long time, and can become gummy and tacky over time. □

Janet A. Collins runs the Workshop Program at North Bennet Street School in Boston.

INSTALLING THE DRAWER BOTTOM



Raised-panel drawer bottom. Once the drawer bottom has been sized and beveled at the tablesaw, handplane the bevels to fit.



Slide the bottom in place. Beveled sides of the bottom should fit smoothly into the drawer grooves. A single screw at the back—and no glue—is all that is needed to hold the bottom in place and allow for seasonal movement.

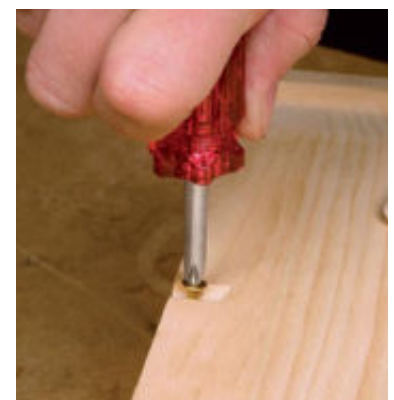

Side-Hung Drawer Slides

No-nonsense approach keeps drawers running straight and smooth



Drawer guide,
attached to case side

Groove in
drawer side

EASY TO INSTALL

Wooden guides are mounted to the case sides and mate with grooves in the drawer sides. The guides support the drawer in the open and closed positions and also serve as drawer stops.



BY MARK EDMUNDSON

Over the years, I've constructed all sorts of drawer systems, from traditional drawer pockets consisting of rails, kickers, and runners, to elaborate center-hung guides. But nothing beats the simplicity and adjustability of side-hung guides. With this system, wooden guides are mounted to the case sides or table aprons and mate with grooves in the drawer sides. The guides support the drawer as it is opened and closed, and they also serve as the kickers (to prevent tipping) and drawer stops.

You will find side-hung drawers on everything from utility cabinets to elegant chests of drawers to tables—and for good reason. Without the need for the rails of a traditional drawer pocket, side-hung guides allow you to design a bank of drawers with a clean, uninterrupted façade. They also allow for deeper drawer boxes.

Most important, however, is the straightforward installation. Side-hung guides make it easy to achieve perfectly fitting drawers in a chest or table and will provide smooth-gliding service for many years.

Side-hung guides simplify a chest of drawers

Fitting drawers is an exercise in trial and error. Too tight a fit, and the drawer will jam when the weather is moist; too sloppy a fit, and the drawer will bind and slide roughly in the opening. Using side-hung guides does not exempt you from building a cabinet with a straight and smooth drawer pocket, but it does simplify the process of hanging a bank of drawers.

Make the guides as thick as possible—When sizing the guides for a chest of drawers, consider how much weight the drawers will carry. In general, drawers that carry a lot of weight need beefier guides. A rule of thumb is to make the guides about $\frac{3}{4}$ in. to 1 in. wide and as thick as possible without compromising drawer strength. Also, because of the abuse the guides must endure, make them of a hard-wearing wood, such as teak or ash. Teak is ideal because its oily nature makes for smooth-gliding action.

Side-hung guides have a couple of key requirements when it comes to the drawer construction. First, the sides must be thick enough to allow for the grooves that mate with the guides. Generally,

Side-hung guides simplify table construction. They eliminate the need for traditional rails and kickers to support the drawer. In tables, the guides must be a bit wider than they are thick so that they can clear the inside of the legs.





Cut the grooves first

Installing a bank of drawers that ride on side-hung guides is simplicity itself. Build the case and drawers, cut grooves in the drawer sides to house the guides, and mill up the guides. Then install the guides in the case, one pair at a time, using a plywood spacer for accuracy (see pp. 92-93).

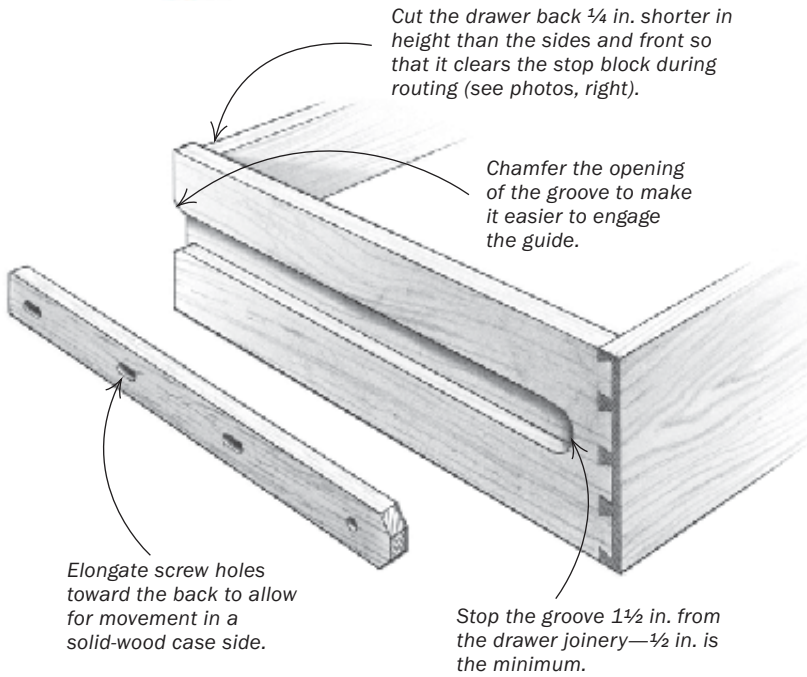

LOCATE GUIDES IN OR NEAR THE CENTER OF THE DRAWER SIDES

When fitting the guides to the drawer grooves, make them a hair thicker than necessary. Plane them down later to get a perfect-fitting drawer. Leave at least $\frac{1}{4}$ in. of material between the bottom of the groove and the inside of the drawer.

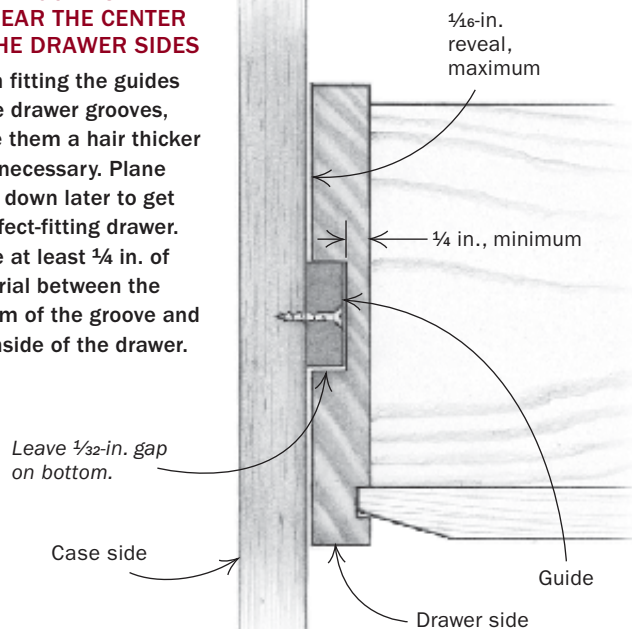

Take light cuts and hold the drawer firmly. A $\frac{1}{2}$ -in.-thick MDF strip clamped to the tabletop (above) prevents the drawer from jumping away from the fence. The stop block clears the lower-cut drawer back but hits the front (right), so the groove ends in the right spot.

for strength there should be at least $\frac{1}{4}$ in. of wood remaining between the bottom of the groove and the inside of the drawer. Also, cutting the drawer back about $\frac{1}{4}$ in. shorter in height than the sides and the front allows you to plow the grooves in both sides with only one stop setup.

Cut matching stopped grooves in the drawer sides—To make things go smoothly when building a bank of drawers, create a story stick out of scrapwood that shows all of the drawer heights, the reveal between each drawer, and the guide/groove locations. If all the drawers are the same size, you can use the same router setups for all the cuts. For drawers of different heights, you'll have to adjust the fence and stop, as needed.

Start by transferring the groove location from the story stick to each drawer side. Mark the top, bottom, and depth of the groove (the thickness of the guide). If the drawers are all the same size, you don't need to transfer this location to every drawer.

Next, chuck a straight bit in the router. Ideally, you should use a bit with the same diameter as the width of the groove. If that's not possible, set up the fence to cut one side of the groove.

After cutting to depth, readjust the fence in or out to plow the rest of the waste.

To ensure the same length groove and stopping point for the drawer, I devised a stop-block setup that works for the cuts on both sides of the drawer (see photos, facing page). I typically stop the groove $1\frac{1}{2}$ in. from the front of the drawer. There's no hard-and-fast rule here, but to avoid compromising the joinery at the drawer front, you should clear it by at least $\frac{1}{2}$ in.

The stop can be made from scrap about $\frac{1}{2}$ in. thick and wide enough to be clamped to the router-table fence. To determine the length of the block, measure the distance from the front edge of the drawer to the stopping point of the groove. Subtract the thickness of the drawer front, multiply that number by two, then add the diameter of the bit. For example, if you are using a $\frac{3}{4}$ -in.-dia. bit and want the groove to stop $1\frac{1}{2}$ in. from the edge of a drawer front that's $\frac{3}{4}$ in. thick, make the stop block $2\frac{1}{4}$ in. long.

Mark the center of the stop block, align it with the center of the router bit, and clamp it in place. To keep the drawer from wandering away from the fence, create a channel for it by adding a long strip

Then mill the guides to fit

Begin by planing the guides slightly thicker than the depth of the groove before cutting them to width and length. Check their fit in the drawer grooves. Leaving the guides slightly proud of the sides will allow you to plane them down later to get a perfect-fitting drawer.



1 **Tight, but not too tight.** The guides should ride in the grooves smoothly with very little slop top and bottom.



2 **Smooth the edges and chamfer the tips.** Sand lightly and chamfer the tips of the guides to make installation easier.



3 **Drill pilot holes for the screws.** In solid-wood construction, be sure to elongate the holes toward the back of the guide to allow for wood movement in the case sides.

A spacer makes installation easy

A ½-in.-thick plywood spacer ensures that pairs of guides align perfectly. For accuracy, mark the front edge of the spacer near the bottom and keep that edge toward the front for each pair of guides. Work from the top down.

1. Clamp the plywood spacer inside the case and lay the guide on the top edge.

2. Adjust the guide laterally, then drive screws only in the elongated holes.

3. Once both guides are in place and the drawer fits perfectly, drive home all the screws.

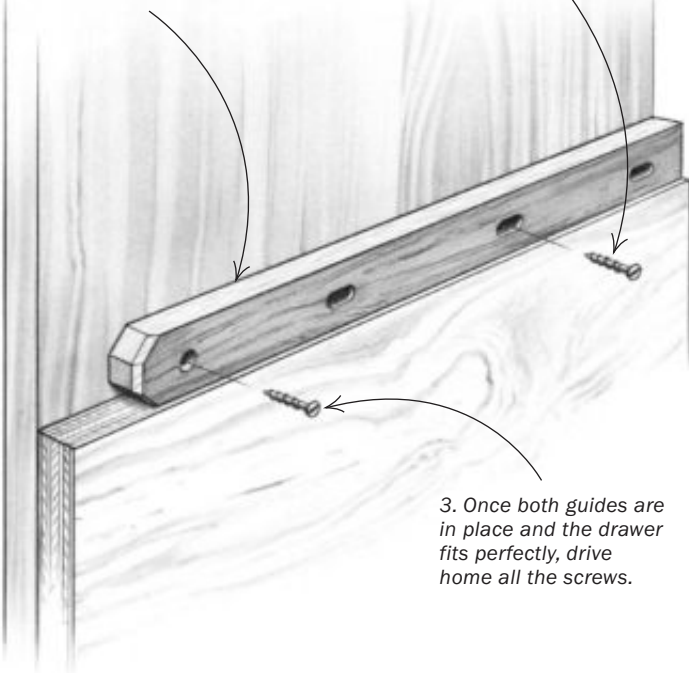

1 **Clamp the spacer to one side.** Place the guide on the spacer and use a square to set it back the correct distance from the case front (to set the square, measure from the drawer front to the groove).



2 **Screw the guide in place.** Drive screws only in the elongated holes for now. This makes it easy to adjust the guide in or out later when you're fitting the drawer. Slide the spacer to the other side of the case and repeat.



3 **Test the fit as you go.** If the reveal is not right, remove the drawer, loosen the screws, and slide the guides forward or backward as needed. If the fit is too tight, carefully plane or sand the guides.



4 **Rip and repeat.** After the top drawer has been fitted, repeat the installation process for the drawers below. Cut the spacer to the proper width, install the guides, and test-fit the drawer.

of plywood or medium-density fiberboard (MDF) clamped to the router table. Leave about 1/32 in. of clearance between the strip and the drawer so that the drawer slides smoothly without jamming.

Now you're ready to rout. For a smooth finish, take light passes, gradually raising the bit to final height. The stop block will clear the drawer back but will hit the front. Don't ram the stop block and knock it out of alignment; allow the drawer front to just kiss

the block. Cut one side, flip the drawer, then cut the other side, running the same reference surface against the fence. One of these cuts will be a climb cut, which will want to pull the workpiece into the bit. A light cut and the channel will help with control.

Smooth grooves mean smooth drawer action, so clean up rough spots along the edges, lightly sand all surfaces, and ease the edges with fine sandpaper. To make it easier for the drawer to engage the

guides, use a chisel to chamfer the back of each groove. After the grooves have been routed in the drawer sides, check them against the story stick to see that nothing has changed and then mill up the guides and fit them to the grooves.

Use a spacer to help with alignment and installation—

The story stick will tell you where to install the guides, but it won't help you keep pairs level front to back and parallel to one another. To help with that, I make a spacer out of 1/2-in.-thick plywood, cut to a length that's just shy of the case opening. To use the spacer, first transfer the location of the bottom of the top guides from the story stick to the spacer. Then rip the spacer to that width on the tablesaw.

Slide the spacer into the carcass opening, clamp it against one side, and mark the front of the spacer. Place the guide on top of the spacer in its correct location, then screw it in place through the elongated holes only. Now clamp the spacer to the other side of the cabinet, keeping the front edge toward the front of the carcass. Install the opposite guide and test-fit the top drawer. If the drawer stops too far in or too far out of the case opening, you can easily loosen the screws in the guides and slide them in or out to correct the problem. When the drawer fits perfectly, drive home the rest of the screws in the guides.

Rip the spacer to width so that it reaches the bottom of the next set of guides, and follow the same procedure. Work your way down the cabinet until all the guides are installed.

Table-mounted guides have a different setup

In tables, side-hung guides share many of the same design principles as those used in a chest of drawers, but the anatomy and construction of table-mounted guides are a bit different. When incorporated into a table, side-hung guides typically are a bit wider than they are thick so that they can clear the inside of the legs. To add strength and to make registering and aligning the guides easier, I house the guides in shallow grooves in the table aprons. I attach the guides with glue and screws (see drawing, right).

Cut and fit the guides before cutting the drawer grooves—

When installing side-hung guides in a table, first build the drawer and fit it to the opening. Next, cut and fit the guides and chamfer the tips where they will engage the grooves in the drawer sides. Install the guides, but don't glue or screw them in place yet.

Because you are cutting the grooves in the drawer sides to fit the guides, the router-table settings must be spot-on. To set the fence the correct distance from the bit, measure from the bottom of the top rail to the top of the guide. For the stop-block setting, measure from the front of the leg to the tip of the guide (for more on setting up the stop block, see p. 90). Test the setup on a scrap piece the same width and thickness as the drawer sides. Once the settings are perfect, rout the grooves in the drawer sides.

After cleaning up the grooves, test the fit of the drawer. If the fit is too tight, remove the guides and plane them to height or width as needed. One important thing to keep in mind: If you need to plane down the height of the guide, be sure that you do not remove material from the area that engages the groove in the table apron; doing so could ruin the fit of guide to groove. When you have the drawer running true and smoothly, glue and screw the guides in place. □

Mark Edmundson is a furniture maker in Sandpoint, Idaho.



Side-hung drawers in a table

MAKE GUIDES WIDER TO REACH PAST LEGS

When using side-hung guides in a table, there are few parts to mill up and fit. The guides typically are wider than they are thick so that they can clear the inside of the legs. The guide should project 1/4 in. beyond the inside of the leg.

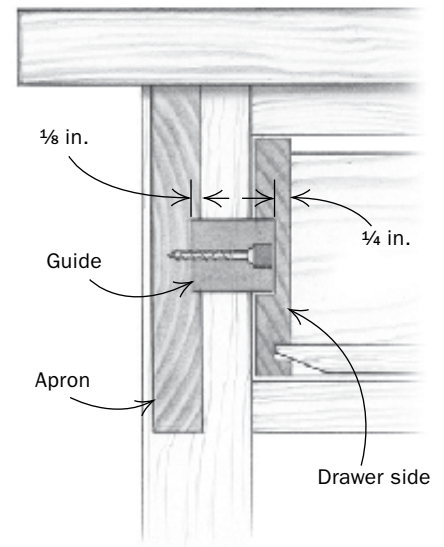

Long-lasting connection. In a table, the guides are wider to reach past the legs. They can be glued and screwed and even set into grooves in the aprons.

Doors for Furniture

An illustrated guide to door construction



ENTRY DOOR



QUEEN ANNE CUPBOARD

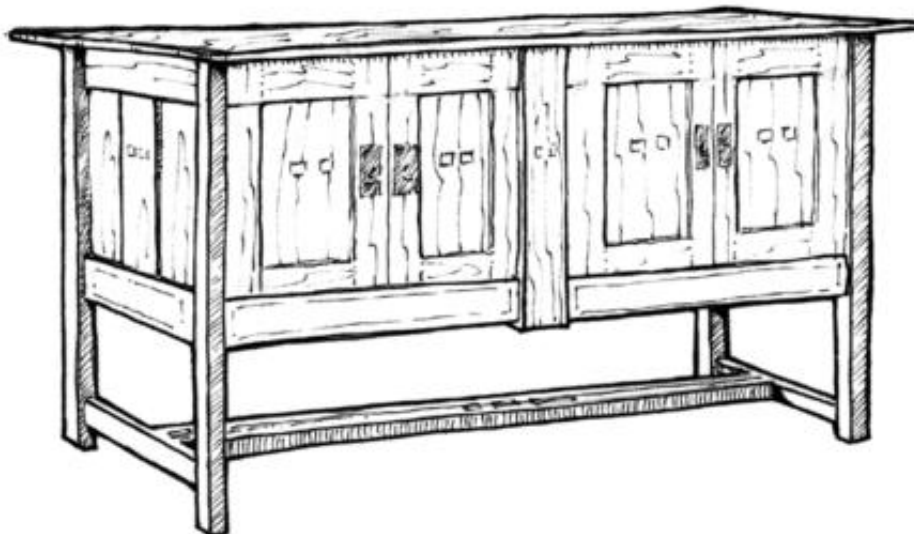

ARTS AND CRAFTS SIDEBOARD

**BY GRAHAM
BLACKBURN**

Before the advent of frame-and-panel construction, doors (and their owners) were at the mercy of wood movement. Solid-plank doors were unruly—likely to split, warp, and twist. Subject to expansion and contraction across their entire width, solid-plank doors gaped open when the weather was dry and swelled shut when it was wet. Frame-and-panel construction changed all that. Instead of ignoring or resisting wood movement, the frame-and-panel door was designed to accommodate it.

Frame and panel soon became one of the indispensable building blocks of work in solid wood, used not just in doors but in all sorts of case construction and paneling. Over the centuries, the range of its applications has been equalled only by the diversity of stylistic treatments it has received.

Given all this variety, where does a woodworker start when designing frame-and-panel doors? With the structure. It is my feeling that before you can make something look good, you have to be able to make it work well. Once you understand why and how frame and panel works, you are halfway to a successful design. In the drawings on the following pages, I've laid out the underpinnings of frame-and-panel construction along with

JOINERY AND PANEL OPTIONS

Joinery options for frame-and-panel doors depend on the size and function of the door, while panel choices are based more on aesthetics than on structure.

THREE WAYS TO JOIN THE FRAME

Lighter cabinet doors, especially those with glued-in plywood panels, may be joined with biscuits or dowels.

For a more sound connection, use a mortise-and-tenon joint. A haunched tenon increases the joint's resistance to twist.

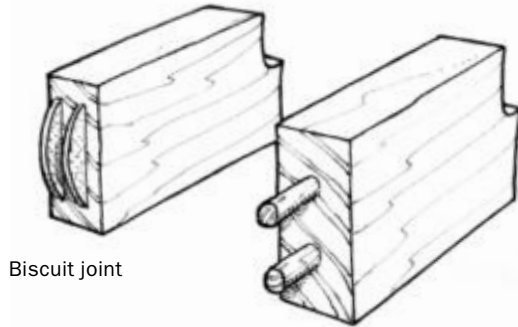

Biscuit joint

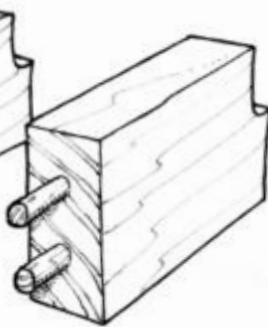

Dowel joint

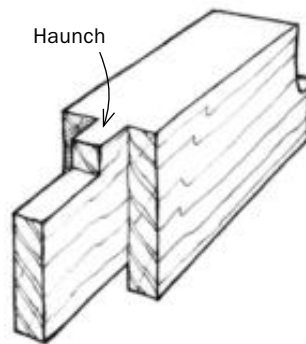

Mortise and tenon

JOINERY LAYOUT

Cutting the panel grooves in line with the mortises and tenons makes layout and execution easier.

Haunch fills through-groove.

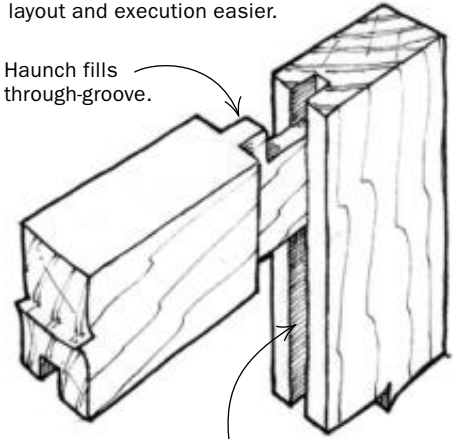

Panel groove

PANEL-HOLDING OPTIONS

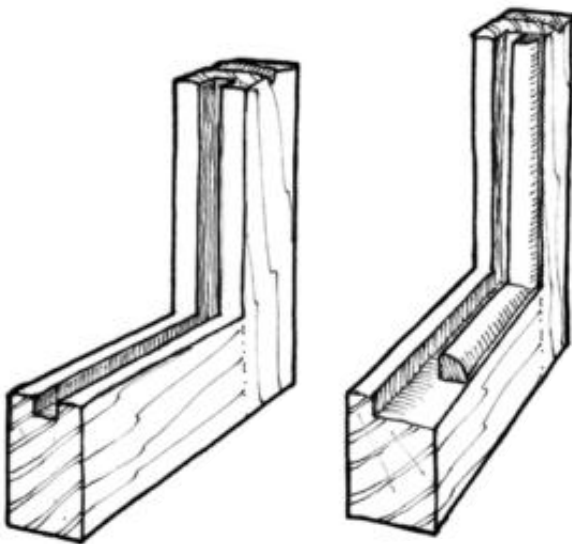

Integral groove

Rabbet with applied molding

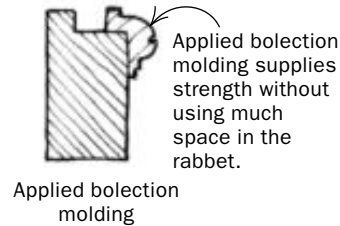

Applied bevel molding supplies strength without using much space in the rabbet.

Applied bevel molding

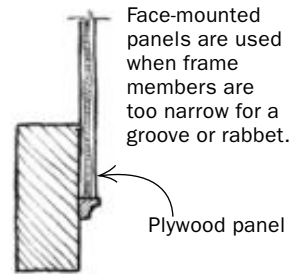

Face-mounted panels are used when frame members are too narrow for a groove or rabbet.

Plywood panel

Face-mounted panel

COPE AND STICK

An profiled edge is said to have a "stuck" molding.

The corresponding contour is "coped."

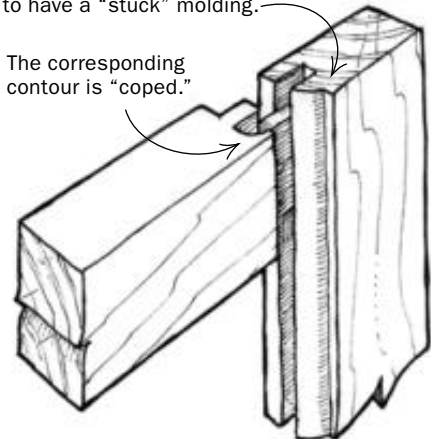

Note: On small cabinet doors, a stub tenon (no mortise) suffices for joinery.

PANEL VARIATIONS

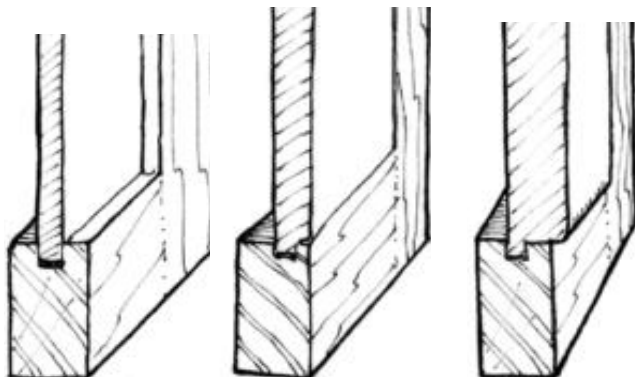

Flat panel

Flush panel

Proud front panel

A fielded panel is one with a defined center section: the field. For cabinet work, panels are generally flat on the inside face.

Fielded panel

Although the term is often used more broadly, a raised panel is one in which the center, or field, is defined by a shoulder.

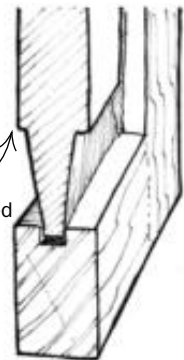

Fielded and raised panel

Entry-door panels often are raised on both sides.

considerations that inform the design process.

Wood moves freely in a frame-and-panel door

The simple genius of the frame-and-panel system is in making a dimensionally stable frame of narrow members surrounding a solid-wood panel that is allowed to expand and contract freely with changes in humidity levels.

The panel may be large or small, plain or simple, but as long as it is made of solid wood, it must be given freedom to move (so that it will not split or buckle with changes in humidity) and at the same time be held securely (so that it cannot warp). Panels are typically held by their edges in grooves formed in the surrounding frame, and they are pinned or glued only at the center. Occasionally, the grooves are formed by adding a strip of molding to a rabbet, but most often the groove is integral to the frame.

The frame members are most commonly mortised and tenoned together, although other methods, such as biscuits or dowels, can be used (see drawings, p. 95). Because most panels are oriented with their grain running vertically, the rails have the most work to do in preventing the panel from warping. Therefore, the rails are usually the widest parts of the frame. The top rail is often made a little narrower than the bottom rail, so that the frame does not appear top-heavy. The stiles are generally made narrower still, giving a pleasing appearance and minimizing the seasonal change in the width of the door.

The proportions of the frame joints may vary, depending on the size and function of the piece: More substantial doors should be joined with tenons approximating one-third of the thickness of the members;

WHY FRAME-AND-PANEL DOORS ARE BETTER

DESIGNING A DOOR TO LAST

Solid-plank doors are at the mercy of seasonal changes in humidity. Hence, they are unlikely to fit their openings in both summer and winter. Frame-and-panel construction solves the problem, making a stable frame and allowing a solid panel to expand and contract inside it.

PLANK-AND-BATTEN DOOR IGNORES WOOD MOVEMENT

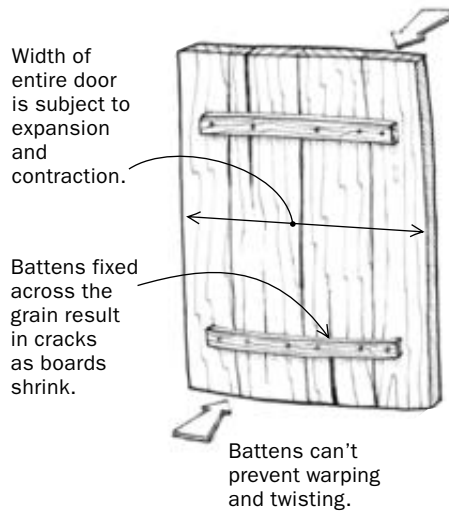

FRAME-AND-PANEL DOOR ACCOMMODATES WOOD MOVEMENT

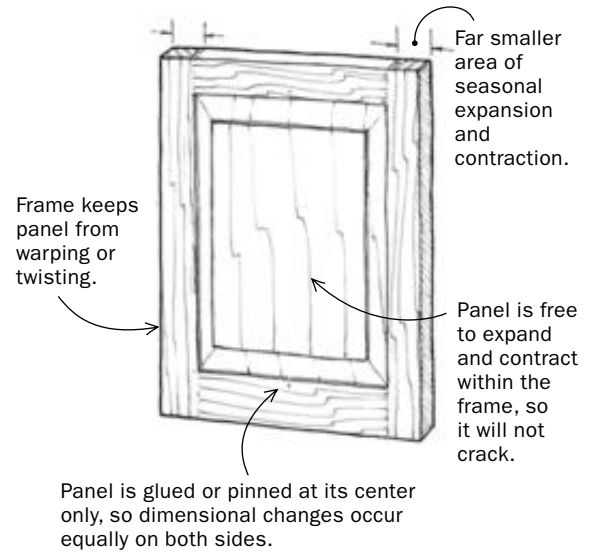

BASIC STRUCTURE OF A FRAME-AND-PANEL DOOR

In a typical frame-and-panel door, the stiles run through from top to bottom, and the grain in the panels is vertical. The rails are generally wider than the stiles, providing wider tenons and better resistance to warping of the panels. One rough rule suggests that if the bottom rail is one unit wide, the top rail should be two-thirds of a unit wide and the stiles one-half of a unit wide.

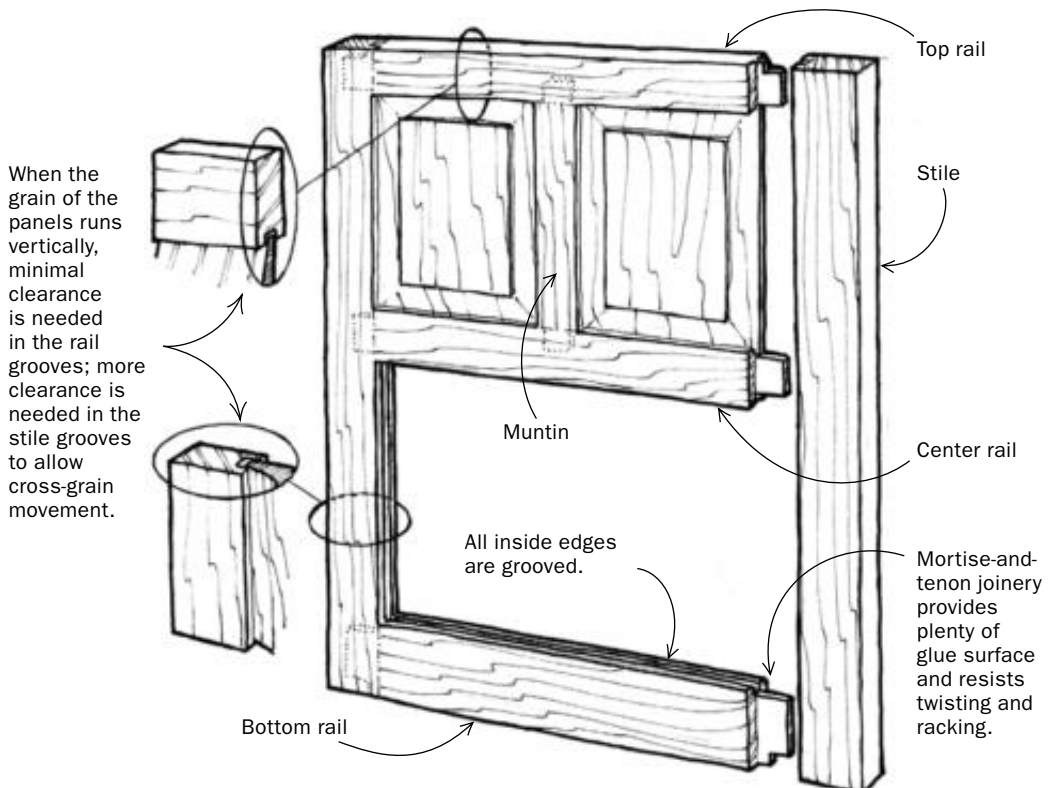

DESIGN OPTIONS FOR FRAME-AND-PANEL DOORS

DESIGNING WITH PERIOD STYLES

Use period characteristics to design a door in harmony with its surroundings.

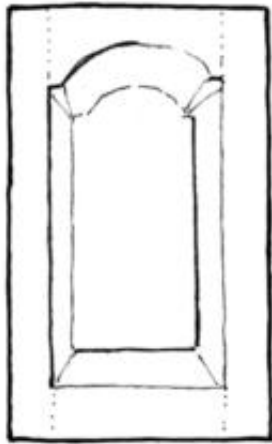

18th century
Classic proportions, raised panels; made of mahogany.

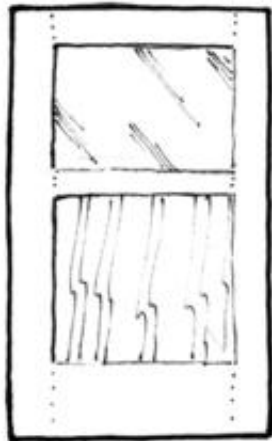

Contemporary
Geometric proportions, unadorned forms; made of contrasting materials.



Victorian Gothic
Emphasis on vertical elements, pointed arch panels, linen-fold carving; multicolor finishes on walnut or fumed oak.

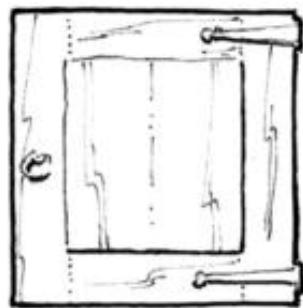

Arts and Crafts
Bold, simple forms, minimal molding, wrought-iron hardware; made of oak.

PROPORTIONING BY THE BOOK

Although the designer's eye should always be the final judge of what looks good, there are a number of traditional systems you can use to establish pleasing proportions.

THE GOLDEN MEAN

The golden mean may be expressed as a ratio, BC:AB as AB:AC. This is approximately 5:8.

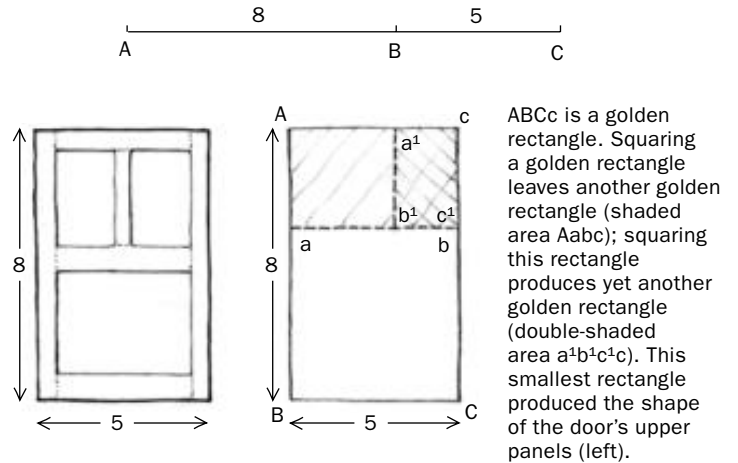

THE CLASSICAL ORDERS OF ARCHITECTURE

The Tuscan column (the first of the five classical orders of architecture) is built on a ratio of 1:7. The column width = 1, the column height = 7. All other dimensions are multiples or fractions of this ratio; for example, the base and the capital are each one-half the column width.

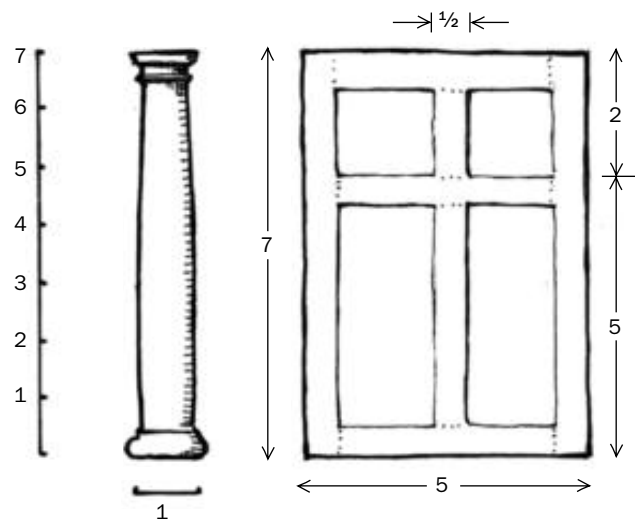

Use the ratio of the Tuscan order (or any other order) to proportion a door. Divide the height of the door by seven, then use multiples or fractions of the resulting unit to size the panels and frame members. (For an 84-in. door, the unit would be 12 in.)

FineWoodworking.com

In a video, Graham Blackburn discusses design options for frame-and-panel doors. Go to www.finewoodworking.com/buildingfurniture.

joints for lighter doors may be a quarter of the thickness.

Sound design combines strength and aesthetics

Working up the proportions of a door's parts from a structural standpoint will go a long way to producing a pleasing design. But without compromising structural integrity, there remains much you can do to control the final appearance.

You can change the apparent shape of any door by altering the size, shape, and number of framing members and reinforcing the message with compatible grain patterns. To make an extremely vertical door appear less tall and narrow, for example, try using multiple rails and orienting the grain of the panels horizontally, or make a square door stretch vertically by giving it a number of tall, narrow panels. If you are designing a long, low piece and are concerned it will appear squat and heavy, you can give the piece more lift by dividing the doors so the upper panels are smaller than the lower ones.

To avoid visual confusion, pick out certain elements of the design for emphasis. For example, you might use plain panels in an unusual frame or surround a panel that has striking grain with a straight-grained frame.

Whatever else is required, design in harmony with other woodwork in the room. Even if you don't design in the exact style of the surroundings, try to include elements that will relate, such as elegantly raised panels in a piece destined for a roomful of Colonial furniture or flat panels for a piece that will live with Arts and Crafts furniture. □

Graham Blackburn is a furniture maker and publisher of Blackburn Books (www.blackburnbooks.com) in Bearsville, N.Y.

DESIGN OPTIONS FOR FRAME-AND-PANEL DOORS, CONT.

WORKING WITHIN A GIVEN SPACE

Even if you are restricted to a particular space or shape, you can create different visual effects with frame-and-panel doors by changing the visual focus.

DESIGNS FOR A SQUARE OPENING

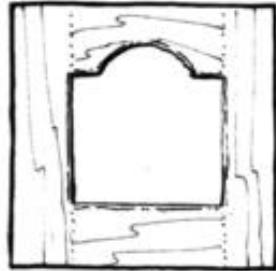

Focus on the framing
Concentrate on the frame members, and keep the color and pattern neutral.

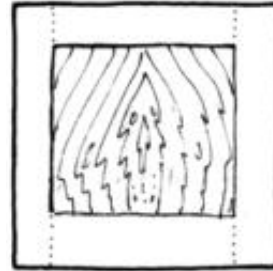

Focus on the panel
Use dramatic grain matching or veneer within a plain frame.

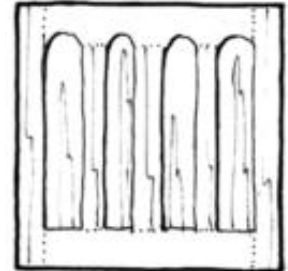

Stretch the square
Downplay the squareness of the opening by designing a door with strong vertical elements.

DESIGNS FOR A VERTICAL OPENING



Restate the shape
Keeping the design as simple as possible preserves the essential shape of the opening.

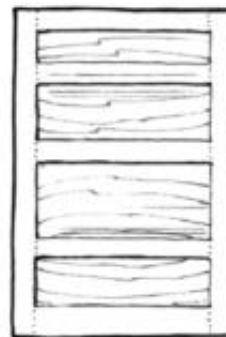

Accentuate the lateral
Introducing strong horizontal elements—three center rails, wide panels with strong grain running side to side—offsets the door's verticality.

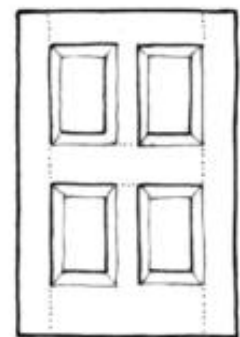

Beef up the rectangle
Raised panels make a door look stronger and heavier; a traditional four-square approach with slightly taller bottom panels provides good balance in a rectangular opening.

MULTIPLE DOORS FOR A HORIZONTAL SPACE

Stiles at both ends of a cabinet are made double-wide to balance the paired stiles between. Placing the center rail above the mid-point creates tall lower panels, which give the long, low cabinet a vertical emphasis. For visual balance, the top rail plus the cabinet top equal the width of the bottom rail.

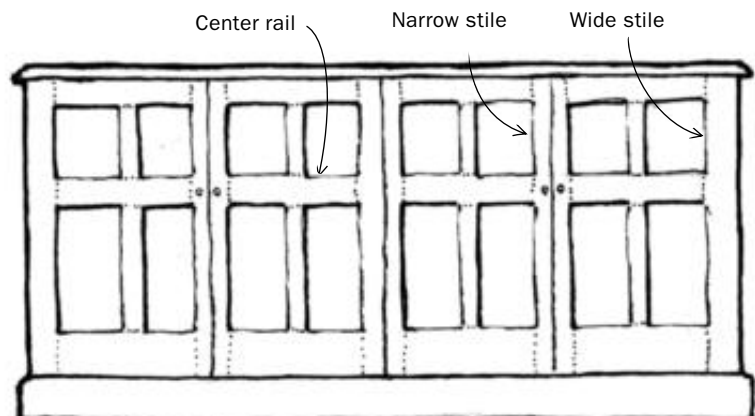

Handmade Catches and Latches

Four elegant ways to keep doors in place



Hidden Magnets

BY ANDY RAE



Shaker Spinner

BY CHRISTIAN BECKSVOORT



Flipper Catch

BY DOUG NOYES



Button Catch

BY MICHAEL PEKOVICH

Look through a catalog of cabinet hardware and you'll find dozens of gadgets made for keeping doors shut. Nonetheless, many woodworkers create their own catches and latches because they're attractive, not difficult to make, and cost little. Another benefit is that you won't see any clunky metal hardware in the cabinet. We asked four woodworkers to show us how they keep cabinet doors closed. The solutions include hidden rare-earth magnets, a traditional Shaker spinner, a wooden flipper catch made popular by James Krenov, and a button catch. All of these clever devices look a lot better than most store-bought hardware, and they can be customized to fit your needs.



Hidden Magnets

Use the power of rare-earth magnets to keep a door closed

BY ANDY RAE

To keep cabinet doors closed, I often rely on the magnetic attraction of rare-earth magnets mortised into the top and bottom of the door and frame. The magnets pull the door flush to the case once it swings closed—a satisfying effect, especially if the door has been fitted to close tolerances. I cover the magnets with wood plugs for a clean, hardware-free look.

Keep in mind that this technique works only with free-swinging doors. Avoid using this method with self-closing or other spring-loaded hinges.



Drill mortises before gluing up the case. One set of magnets is recessed into mortises drilled into both the case top and bottom.

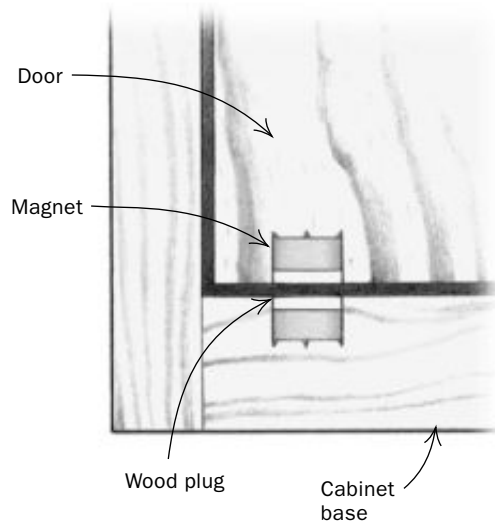

Rare-earth magnets are my preferred pullers. Size them based on the thickness of the door and frame. For 1/2-in.-thick doors, you can use 3/8-in.-dia. magnets; 1/2-in.-dia. magnets work best for doors that are 3/4 in. thick.

Installing the magnets

Drill the mortises for the magnets in the case pieces before assembling them. Offset the mortises in the case toward the rear, which will help pull the door closed. Make the mortises 1/4 in. deep to allow for the 1/8-in.-thick magnets and the wood plugs that hide them. To make clean, flat-bottomed mortises, use a Forstner bit.

To determine the door mortise locations, the door must be hung first. So go ahead and assemble the case and build the door. Take your time getting a consistent door reveal. Once you've installed the magnets



With the case assembled, transfer the mortise location. Use a piece of tape to hold the door flush with the outer edge of the case.



Mark the magnets to ensure that they are oriented correctly. Glue the magnets in place, add wood plugs, then pare and sand the plugs flush.



and covered them with plugs, you'll have little room for adjustments. I aim for a reveal of about 1/32 in. so that the door slows on a cushion of air as it is shut, then is quietly drawn in by the magnets.

With the door hung, transfer the centerline of the mortise in the cabinet to the bottom and top of the door. Remove the door and drill the mortise for the magnet. The best way to get precise mortises in the door is to use a drill press. But the job can be done with a handheld drill if you use care. Practice on scrap, and wrap a piece of masking tape around the bit to flag the correct depth.

Establish the proper polar orientation of each pair of magnets and mark them with a felt-tipped pen. Use epoxy or cyanoacrylate glue to secure the magnets. Now reinstall the door. If the mortises have been drilled correctly, the magnets will pull the door flush to the face of the cabinet.

Cover the magnets with wood plugs. By carefully matching the grain orientation of the plugs, they will disappear, and your friends will wonder what kind of magic is holding the door in place.

Andy Rae is a cabinetmaker, furniture maker, teacher, and writer in Asheville, N.C.



Shaker Spinner

The simple spinner is refined to become an elegant latch

BY CHRISTIAN BECKSVOORT

Spinners have been used for years to keep barn doors shut. I've redesigned the spinner for my cabinets from the simple but effective exterior latch to a refined and almost completely hidden mechanism within the door stile.

The earliest spinners consisted of a small piece of wood with a pin through the center mounted on the frame next to the door. With the spinner in the vertical position, the door can be opened. With the spinner turned horizontally, the door is locked.

A few years back, I decided to incorporate the spinner inside the lock stile of the door frame. I make the spinner into an oval. The result is substantially more work in layout, mortising, and fitting, but it's much cleaner-looking and is almost entirely out of the way.

The doorknob must be placed on the centerline of the door stile, and the spinner must extend out of the stile by at least 1/4 in. when closed, yet fit completely within the door stile when in the fully opened position. Begin by drilling the knob hole through the stile. Then make a cardboard cutout of the spinner, sized so that it won't reach into the door-panel groove. Locate the mortise by swinging the cutout in a 90° arc around the doorknob hole. The width of the mortise should be about a third the thickness of the door frame—say, 1/4 in. for a 3/4-in.-thick frame.

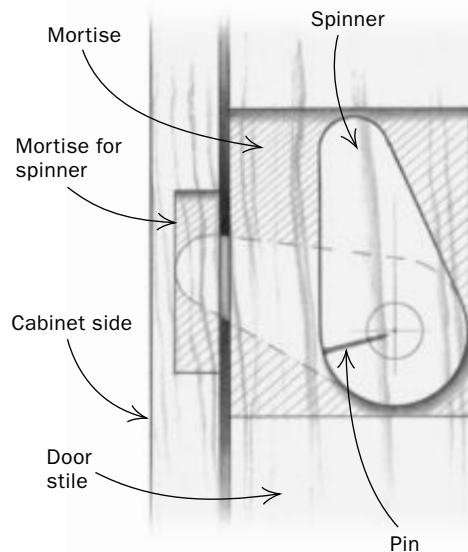

Lay out the mortise in the door. With the knob drilled in the center of the stile, use a cardboard cutout to determine the spinner's placement. Then mark the mortise 1/4 in. larger than the spinner itself.

Once the mortise is complete, shape and drill the spinner.

I aim for close tolerances between the knob shaft and matching hole. For most cabinet doors, I use knobs with 1/2-in.-dia. shafts (3/8 in. dia. for very small doors). To

make life easier, I shape all knob tenons with a plug cutter, chuck them into the lathe, and turn the knob proper. If you think about it, the knob shaft is the only critical part of the process. The 1/2-in.-dia. shaft must fit precisely in the matching hole bored into the door. The plug cutter eliminates the most difficult portion of the task.

For a 1/2-in.-dia. knob shaft, drill a 33/64-in.-dia. hole through the door stile and a 1/2-in.-dia. hole through the spinner. Now the knob will spin freely in the door frame yet hold the spinner securely. If all works well, you will pin it in place with a small brad or a brass escutcheon pin. The spinner should not be glued, because there's a great risk of glue getting onto the knob shaft and mucking up the works.

With the spinner to the closed position, align the grain of the knob with the grain of the door frame. Then turn the spinner into the open position and pin it. Now the grain of the knob lets you know whether the spinner is open or closed.

After 30 years as a woodworker, I was proud of myself for coming up with this idea of installing the spinner in the door frame. Then in 1996, while shooting photos for *The Shaker Legacy* (The Taunton Press, 1998), I came across a small chest with drawers and doors at the Art Complex Museum in Duxbury, Mass., in which the door knob passed through a mortise in the edge of the door. Although the spinner itself was missing, it was clear that the Shakers had the same bright idea more than 160 years ago.

Christian Becksvoort is a furniture maker of 45 years and a contributing editor to Fine Woodworking.



Chop out the mortise. Becksvoort chisels out the mortise by hand.



Drill for the pin. To avoid splitting the spinner, drill a hole for a small brad or pin.



Slide in the knob and spinner. The knob should go in easily, and the spinner should swing freely and be hidden when the latch is open.



Flipper Catch

A spring-loaded solution to keeping doors closed

BY DOUG NOYES

I discovered flipper catches in one of James Krenov's books on cabinetmaking. I like these catches because they are easy to make and allow me to utilize exotic hardwood scraps. The one I frequently use is an L-shaped wood flipper that is recessed into a mortise in the case bottom. A small spring keeps the flipper engaged with the bottom edge of the door.

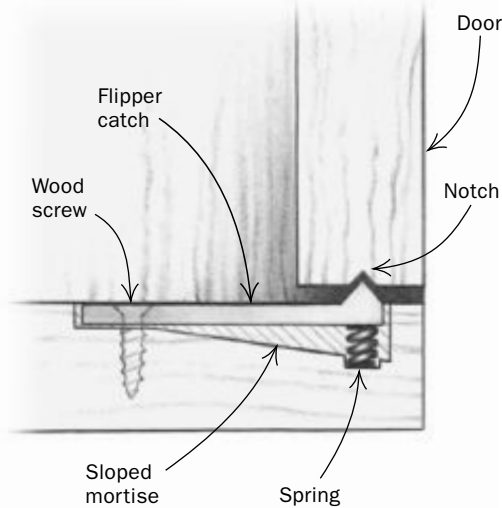

I make the flipper out of a durable hardwood, such as ebony, because it resists wear. Although I make the flipper to fit, one made for a 3/4-in.-thick door will typically measure approximately 1/4 in. thick by 3/8 in. wide by 1 1/2 in. long. Cut it out with a handsaw, then shape the flipper with a file or knife. Drill a slightly oversized hole for the attachment screw. This will allow the flipper to pivot. Countersink the hole so that the screw is flush with the top of the flipper.

Next, cut the sloped mortise, which allows the flipper to recede when the door is closed. Use a plunge router with a fence to make the mortise. It is a short mortise

(only 1 1/2 in. long), so be careful not to cut too deep too fast.

Square up the mortise with a chisel. Drill a hole in the deeper part of the mortise for the spring. The hole should be about 1/8 in. deep and the same diameter as the spring. I use 1/8-in.-dia. springs from ballpoint pens trimmed to 1/4 in. long, but you also can get springs from a hardware store.

Put the flipper into the mortise to test the fit. It should be snug but not overly tight. If it fits, place the spring in its hole, put the flipper in place, and secure the assembly with a small wood screw.

I usually make a shallow notch (1/16 in.) in the bottom of the door to engage the flipper. If the door is made of very soft wood, it's not a bad idea to insert a piece of hardwood in the bottom of the door to prevent excessive wear.

To determine the location of the notch, first close the door several times on the flipper, which will create a shiny spot where it is rubbing. At the end of this shiny spot, make the notch for the door to catch. If this shiny spot does not appear, rub the top of the flipper with a pencil and then close the door. The pencil mark will indicate the location of the notch.

A variation on this catch is to include a positive stop. By shaping a shoulder onto the flipper itself, I can control the closed position of the door. I use this variation on inset-door applications or on double doors that can be opened individually.

A little trimming here and filing there, and you'll have a good catch that makes a subtle "click" when the door is closed.

Doug Noyes is a furniture designer and woodworker in Guilford, Conn.



Cut the sloped mortises. Use a plunge router to make a sloping mortise for the flipper.

Chisel the mortise to length. Scribe the length and width, then pare close to the layout lines. Check the fit often as you work; you don't want to make the mortise too wide.



Catch assembly. The spring sits in a hole bored in the deep end of the mortise, and the screw threads through the back end of the flipper.



Button Catch

Simple, unobtrusive, and easy to make

BY MICHAEL PEKOVICH

I had been floundering in art school for a couple of years when I stumbled into a beginning woodworking class. One of my first projects was a simple pencil box with a sliding lid. At wits' end for a way to secure the lid (short of tying it closed), I approached my instructor, John Snidcore, who showed me a simple, spring-loaded wood button catch.

Twenty years later, I'm still working wood and still using the button catch on a variety of projects. But I have since modified the design to work as a door catch. The concept is simple: A stepped button slides up into a stepped hole from below. A spring supports the button, and a wooden plug covers the bottom of the hole.

Hang the door and locate the button about 1 in. from the edge of the door, mid-point in its thickness. Transfer this location to the bottom of the case. From the bottom, drill a $\frac{3}{8}$ -in.-dia. hole, stopping $\frac{1}{8}$ in. shy of the opposite side. With a $\frac{1}{4}$ -in. bit, continue the hole through the case bottom and use a piece of scrap to prevent tearout. Then wedge the door in the closed position and drill just into its bottom edge to create the cup for the button.

To make the button, simply chuck a short length of hardwood dowel into a drill press. With a file in hand, it's quick work



Shape the button on the drill press. Use a block with a pre-drilled hole in it to gauge the right size of the button.



Drill the stepped hole. Mark the bit with tape to indicate the correct depth.



Drill the button hole. Use some scrap stock to prevent tearout.

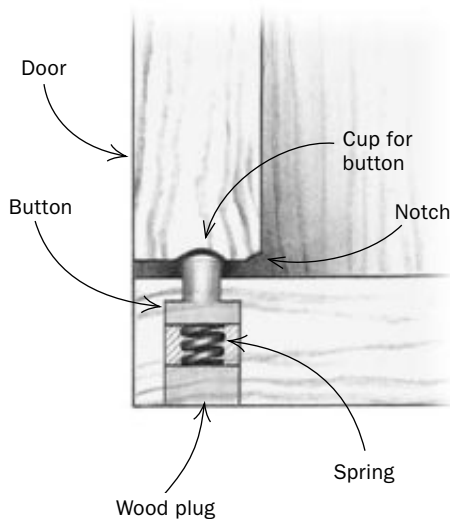

to create the desired profile. After a test fit, cut the button to length. Before doing so, I like to round and polish the top of the button while it's easy to grab. From this point, it's just a matter of inserting a spring in the hole and capping it.

For small projects such as my pencil box, I glue a plug into the hole and finish it smooth. For most case pieces, where long-term maintenance is an issue, I prefer a plate screwed to the case bottom, which allows for easier button replacement, if necessary.



Notch the back edge of the door. The notch is shallow and angled so that it will depress the button as the door closes.

One final task is to use a gouge or carving knife to cut a shallow notch on the inside edge of the door bottom where it strikes the button. This notch and the rounded button top combine for smoother door closing. □

Michael Pekovich, a longtime woodworker, is the art director of Fine Woodworking.

Installing Butt Hinges

Traditional hinge
will look and work
great for decades

BY GARRETT HACK

You can't beat butt hinges for durability, clean looks, and straightforward installation. I'll demonstrate the most common use for this hinge: hanging an inset cabinet door. If you can install hinges in this type of flush door, you can handle any other butt-hinge application.

Woodworking catalogs offer a variety of butt hinges—some steel, others brass; some with thick extruded leaves, others pressed from thin metal. Some hinges, such as those for a jewelry-box lid, have a built-in stop. While these hinges come in a range of lengths and widths, they all have two flat leaves—usually the same size—with a barrel, or knuckle, joining them.

For fine furniture, brass hinges are always my first choice. The best of these have thick leaves that make a strong hinge. Often the leaves are tapered, so they're thicker toward the knuckle for strength where you need it. Low-cost butt hinges are made by pressing thin sheet metal around the pin to form the knuckle.



Extruded hinges are tighter than these pressed hinges because the knuckle is fitted together and then drilled in one shot for a precisely fitted hinge pin. Extruded hinges cost more and may not be available in your local hardware store, but they will keep your doors swinging smooth and true for a long time.

Steel is stronger and tougher than brass, but brass hardware usually looks better on fine furniture and ages well. I avoid steel hinges because they rust. Summer humid-

ity or storage in a basement or unheated space can discolor and tighten a steel hinge. For these reasons, there's a far wider selection of brass hinges than steel.

Pick the right hinge for your door

Two numbers typically describe a butt hinge: the length of the hinge (listed first) and the fully open width (second). A typical cabinet-door hinge is 2 in. by 1¼ in., with leaves 2 in. long and 5/8 in. wide. Some catalogs further classify butt hinges

CHOOSE WISELY

Don't compromise. Choose a high-quality extruded brass hinge (bottom) for your furniture. Cheaper stamped hinges (top) will not be flat, square, or drilled accurately, and there will be slop around the hinge pin.

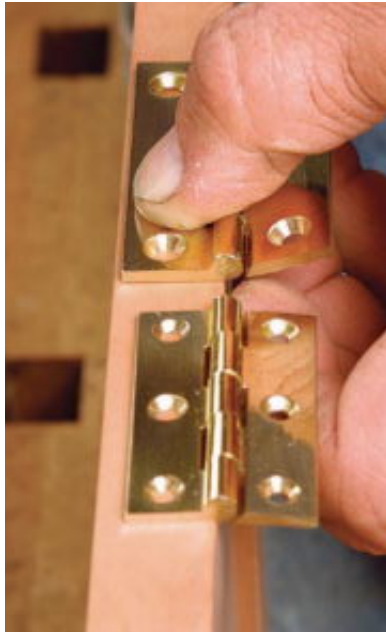

The top hinge is the wrong size for this door. It would leave a fragile sliver of wood at the edge of the mortise. The bottom hinge is a more appropriate size.

THE RIGHT SIZE FOR THE JOB

Choose a hinge size that leaves at least $\frac{1}{8}$ in. of wood at the back of the mortise, or this area will be too fragile. Another option is to choose a hinge that reaches all the way across the stile.

The centerline of the hinge knuckle should be about $\frac{1}{32}$ in. proud of the door and case.

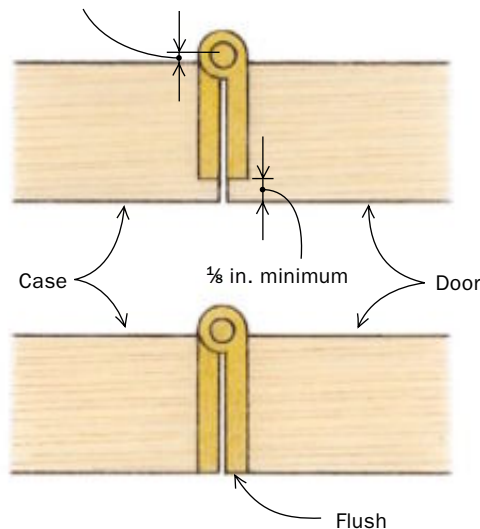

WHERE TO LOCATE THE HINGES

It's pleasing to the eye if you relate the hinge locations to the rails (below left). However, this may not be possible on doors with thin rails (below right).

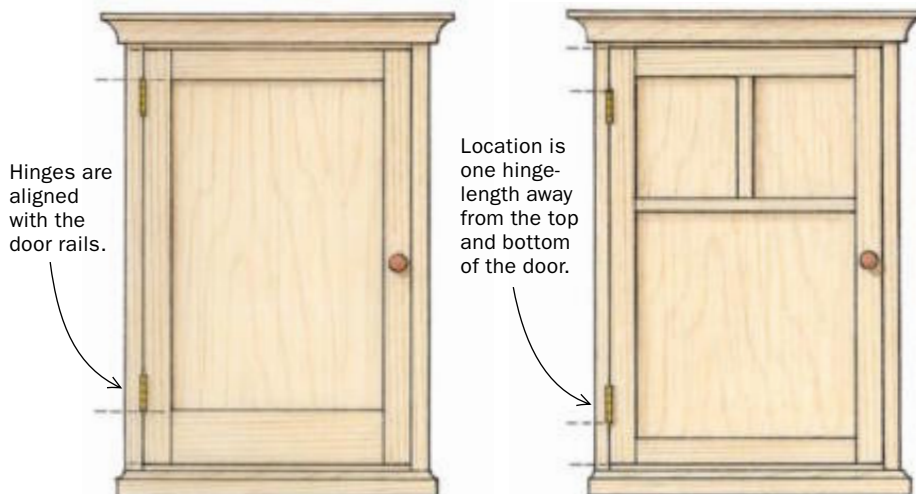

as narrow or wide, but what really matters is the length and width. I prefer fixed-pin hinges over loose pins (the hinge comes apart for lifting off a door easily) because they are stronger with less play in the knuckle.

Choose and purchase hinges during the design stage of a project. You don't want to be ready to hang a door and then realize that the hinge leaf to be mortised into the door is wider than the door stile, or that it leaves just the thinnest ribbon of wood at the back of the mortise that will break away someday. Knowing door and carcass dimensions, you can narrow down the possibilities of hinges that will fit. If you're unsure of the best choice, buy two sizes.

How many hinges and where?—Typically, I use two hinges on cabinet doors under 3 ft. tall. For greater strength and stability (for heavy doors or for doors on which objects will be hung), I prefer to use longer, heavier hinges rather than add a third hinge in the middle of the door. With the leaves snugly mortised and screwed into place, two butt hinges will support a surprisingly heavy door. However, for passage doors and very tall cabinet doors, adding a third hinge in the middle can help hold the stile and door in alignment, keeping them from binding.

A critical aspect in the appearance and action of the door is how far the hinge knuckle sticks out from the front of the door. For the door to swing smoothly without binding, the centerline of the hinge pin need only be slightly proud of the door—about $\frac{1}{32}$ in.

Hanging a flush inset door

After choosing the right hinges for the job, the challenge is to set the hinges precisely, leaving a fine, even gap around the door and a flush surface between the door and the case.

Hinging a door neatly depends as much on building a true door and an untwisted carcass as it does on accurately mortising for the hinges. Slip the door into place and look for any misalignment. Often, there will be some twist in the case or the door, especially if the door is large; this can be addressed in a variety of ways. You can plane the door or case slightly, and you can set one or both of the hinges farther into or out of the case to minimize the effect of the twist. Of course, the idea is

START WITH THE DOOR

Use marking gauges and a marking knife to make fine layout lines. Take all of your settings directly from the hinge for accuracy.

WIDTH

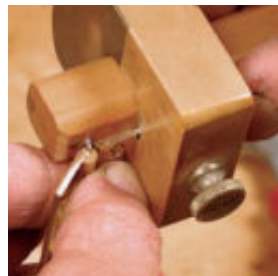

Set the first marking gauge for the width of the hinge. Set it about $\frac{1}{32}$ in. short of the center-line of the hinge knuckle. The light pencil lines at the end of the mortise indicate where to stop the marking-gauge cut.



DEPTH



Set a second marking gauge for the depth of the mortise. If the hinge leaves are tapered, set the gauge at their thickest point.



LENGTH



Again, use the hinge itself to set the length of the mortise. Holding the hinge in place, cut tick marks into the corner of the door stile. Then carry those lines across the mortise with a square.



to head off these problems by using solid construction techniques and stable material to build square cases and doors.

Mind the gap—Every door needs as uniform a gap as possible around all four edges so that the door doesn't stick as it grows or shrinks during seasonal changes in humidity. A narrower gap looks better. Knowing how much of a gap to leave is a matter of

experience and skill. I'm guided by a wide board hanging in my shop whose width I measure from time to time and mark on the board. In early May I leave a slightly wider gap to allow for the higher humidity in the coming months. Somewhere between $\frac{1}{16}$ in. and $\frac{1}{32}$ in. is about right.

Hinges vary in one way that usually isn't indicated in catalogs. If the two leaves do

not close flat on one another, you have an unwaged hinge. This built-in space will be the gap between the door and carcass along the hinge line if you mortise both leaves fully flush. The leaves on a swaged hinge close flat to one another, so to set the door gap, you should mortise the leaves slightly proud of the door or frame stile, or both.

At this point, trim the edges of the door for a close fit all around, leaving a tighter gap than the final one and thus some extra wood for trimming after you've set the hinges. Then shim the door into position with veneer scraps and locate the hinges.

Laying out the mortises—Before you lay out your first mortise, look over each hinge. For a neat mortising job, the leaves should have square and straight sides. Sometimes they will need a little smoothing with a fine file.

To set butt hinges consistently and accurately, use a fine-bladed marking knife, a couple of marking or cutting gauges, one wide and one narrow chisel, and a pencil. Set the mortise width slightly less than the width of the leaf to the center of the hinge pin; this will make the hinge pin and knuckle protrude the proper amount.

Sometimes I mortise the case sides or the frame first, before they are glued up, and then transfer them to the door later. It's easier to work with case pieces loose on the benchtop than it is to wrestle with a large cabinet and to work in the cramped corners of an assembled case or face frame. The cabinet pictured here, however, is small, so I mortised the door first.

Cut very fine lines; heavy cuts will leave a less precise mortise. To see the knife marks clearly, sharpen a pencil to a very fine point and drag it along the lines.

After scribing the width and depth with marking gauges, lay the hinge in position and cut a precise tick mark at both ends. For small cabinet hinges like these, the safest way to lay out the ends of the mortise is to extend these tick marks with a square. For larger hinges, like those used in passage doors, it's better to use the hinge itself to lay out the ends of the mortise. Just be careful the hinge doesn't slip while you are marking.

Chop and pare the mortise by hand

I usually cut hinge mortises completely by hand, with chisels. The first step is to chop out the waste, leaving each knife line

MORTISE IN STAGES



Whether by hand or by machine, the idea here is to clear out the bulk of the mortise before cutting to the layout lines.

TWO WAYS TO REMOVE THE WASTE

Chop it out with a chisel. Make a series of chopping cuts in one direction, then remove small chunks of wood by chopping in the other direction.



Or rout it out freehand. Set the bit depth to the thinnest part of the hinge and stay clear of the layout lines. For thin doors, you can clamp on an extra board to help support the router base.



Finish the mortise with sharp chisels. Chop and pare gradually until you reach the layout lines and get a good fit. Save your widest chisels for the final cuts.

ATTACH THE HINGES AND TRANSFER THE LAYOUT



Mark for the center screw. Offset this location slightly toward the back of the mortise to draw the hinge tightly into place.



Drive in one steel screw. This leaves two hole locations unused to allow the hinge to be adjusted in or out later. Use a steel screw to avoid damaging your softer brass ones.

untouched. Remove much of the wood with a series of aggressive chops down the length of the mortise, then do the same thing in the opposite direction. When 98% of the wood has been removed, creep up to the layout lines with a wide chisel. If you chop down into your layout lines first, the wood in front of the chisel will push it backward, leaving a wider mortise than you intended. Finally, to establish the floor of the mortise, make paring cuts inward from the open side.

For extruded hinges with tapered leaves, the mortise must be slightly deeper at the hinge knuckle. Approximate this taper when you're wasting out the mortise, and fine-tune it later when trial-fitting.

A router can be quicker—Although I finish all of my mortises by hand, I sometimes rough them out with a router, working freehand and going as close to my lines as I dare. Afterward, I finish up the mortise



Transfer the hinge locations to the case. With the hinges installed temporarily in the door, shim the door into its final position and use a marking knife for a precise transfer.

by hand as usual, paring and chopping carefully for a tight fit.

Trial-fitting is important—Trial-fit each hinge to check and adjust its mortise. To find any high spots in the mortise, I scribble on the back of the hinge with a soft pencil, which rubs off when I slide the leaf into place. Trial-fitting can damage the fragile edges of the mortise, so the fewer times you do it, the better.

Attach the hinge temporarily and cut the other mortise

When you are satisfied with the fit of the first hinge leaf, mark for its center screw with an awl, drill, and fix the leaf with a single steel screw.

Cutting the mortises on the carcass is exactly the same as cutting them in the door stiles. To transfer the hinge locations from the door, slip or wedge the door in-

to position with the hinge fully open and make fine knife lines along the top and bottom of the knuckle. A spare hinge of the same size makes it easy to test-fit the mortise and to mark the screw locations. Otherwise, you have to remove a hinge from the door.

Secure each hinge with one steel screw and see how the door swings. The advantage of leaving the door snug in its opening while fitting the hinges is that it allows for some slight mortising errors. You can adjust for these by deepening a mortise or mortises and by planing the door edges for a consistent gap all around.

There's still room for adjustment

A typical problem is that the gap along the hinge line is too large or uneven. The solution is to mortise in one or both leaves of each hinge slightly deeper.

Sometimes, to get a better-fitting door, you may need to pull out a hinge from its mortise slightly, in essence pushing the door farther back into the opening. Fixing the door with only a single screw in each leaf at this point gives you some flexibility to do this, but it creates a noticeable gap at the back of the hinge leaf. Cut a filler piece from a scrap of the same wood, glue it, and then clamp it in place by screwing the hinge leaf into its new position.

Set the brass screws, and you're done

The final step to fitting the hinges is setting the screws. Each hinge is drilled and countersunk for a specific size screw, which is often noted in the catalog description. I order the screws along with the hinges—with a few extras.

If the countersinks are not deep enough, the heads of the screws will stop slightly proud of the hinge leaf. This can cause a hinge to bind and exert tremendous leverage on the screws. If necessary, deepen the countersinks so that the heads end up just below the surface of the leaf. In setting the brass screws, I try to have some consistency in the pattern of the head slots.

If the hinges are installed correctly, your doors and lids should swing sweetly for many decades to come. □

Garrett Hack, a furniture maker and a woodworking teacher who lives in Thetford Center, Vt., is a contributing editor to Fine Woodworking.

INSTALL THE DOOR AND CHECK THE FIT



Cut the mating mortises in the case and attach the door. Continue to use only one steel screw at this point. Check the fit of the door. If necessary, remove the door and plane it to fit.

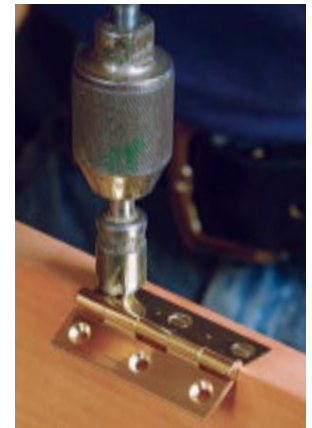

Adjust the countersinks. If necessary, use a countersink bit to deepen the holes in the soft brass hinge so that the screw heads can sit just below the surface.

Making fine adjustments

Sometimes you must shim a hinge up (below) or out (right) to even out the hinge-side gap on a door or adjust the fit of a lid.



If you've cut too deep. To shim a hinge outward, trim a card to fit into the bottom of the mortise.



If you've cut too wide. To move a hinge out toward the front of the case, plane a sliver of long-grain wood to fill the gap at the back of the mortise. Glue it in and plane it flush for an invisible repair.

est. 1978 **HIGHLAND Woodworking**
fine tools & education



The Wood Slicer[®]
LEGENDARY RESAWING BLADE

- CUTS SMOOTHER
- STAYS SHARP LONGER
- WORKS FASTER
- SOUNDS QUIETER
- MAKES VENEERS

800-241-6748 "Best All-Around Performer"
Rated by Fine Woodworking
highlandwoodworking.com

Go online for product information

Find our advertisers' web sites quickly and easily on our online Advertiser Index at www.finewoodworking.com

Fine Woodworking

Keep your Fine Woodworking back issues looking brand new.



Store your treasured copies of *Fine Woodworking* in slipcases for easy reference again and again! Bound in dark blue and embossed in gold, each case holds more than a year's worth of *Fine Woodworking*. Only \$8.95 (\$24.95 for 3, \$49.95 for 6). Postage and handling additional. CT residents add 6% sales tax, Canadian residents please add 7% GST.

To place an order using your credit card, call **1-800-888-8286**. Outside the U.S. and Canada call 1-203-426-8171.

WOODWORKERS MART

ADJUSTABENCH

RAISE YOUR WORK TO A NEW LEVEL

The Noden Adjust-A-Bench is the ergonomic solution for your workshop. Made of steel, it is solid in all positions. Need an assembly table? Drop the Adjust-A-Bench to its lowest position. Routing dovetails? Raise it up. You're always comfortable, regardless of the task.

Leg sets and accessories to retrofit your existing bench or complete workbenches available.

www.adjustabench.com 609-882-3300

Need an affordable tool for routing furniture joints?

New 3 way reading digital scale for precise joinery!



The Craftsman Gallery visit us at... www.chipsfly.com

Career in Woodworking or Hobby?

Certificate Training Program with Job Placement Assistance or Cabinetmaking Fundamentals Intensive

New England School of Architectural Woodworking
www.nesaw.com 413-527-6103

Old English Academy of Fine Woodworking

Michael J. Gray Master

Learn from an Old World Master the Fundamentals & Eruditions of Fine Woodworking

Hands on Instruction for Groups & Individuals

Weekend Classes Year Round
P.O. Box 772 Selmer, TN 38375
www.oefcc.com



Blue Spruce Toolworks

Beautiful hand tools for precision joinery

www.BLUESPRUCETOOLWORKS.com

SCHOOL OF WOODWORKING

DISCOVER the ART of HAND TOOL WOODWORKING

3-Day Finishing & Restoration Courses

1-12 day Courses to Advanced Levels

Catalogue of Courses • (254) 799-1480

In Central Texas www.tccschool.com



HIBDON HARDWOOD, INC.
www.hibdonhardwood.com

Direct Importers of
Central American Exotic Hardwoods

St. Louis, Missouri (314) 621-7711

Connecticut Valley School of Woodworking

Learning by Doing

Hands-on woodworking & furniture making classes for all skill levels—Nights, weekends & week-long classes



 249 Spencer St.
Manchester, CT 06040
860.647.0303
www.schoolofwoodworking.com

SMALL ADS YIELD BIG RETURNS

for advertisers featured in the Woodworker's Mart and Classified sections of *Fine Woodworking*.

For more information call 800-309-8954



WWW.MAKERS-MARKS.CO.UK

TRADITIONAL BRONZE, BRASS & STAINLESS STEEL LABELS

NO MINIMUM ORDER



Philadelphia Furniture Workshop

Hands-On Instruction; All Levels

Mario Rodriguez, Artist in Residence

www.philadelphiafurnitureworkshop.com

215-849-5174



INCH AND METRIC COMPONENTS

- Leveling mounts - Plastic, steel, stainless steel
- Adjustable levers - Tapped and stud type, metal and plastic

18,000 parts. 3D-CAD. eStore.
Find it all at www.jwwinco.com.

 **J.W. WINCO, INC.** Phone 800-877-8351
Fax 800-472-0670

WOODWORKERS MART

HARDWOODS
Lumber • Veneer • Turning Stock
exoticwoods.net
800.423.2450
Wood Descriptions • Secure Online Ordering



WOODWORKERS
Source

18115 N. Black Canyon Hwy. • Phoenix, AZ 85023
645 W. Elliott Rd. • Tempe, AZ 85284
3441 S. Palo Verde • Tucson, AZ 85713

DOVETAILED DRAWERS
Reasonably priced method to distinguish your cabinets.

- Custom-sized width and depth
- 1/2" solid maple, assembled and sanded
- 2-coat catalyzed finish available
- Quick service, shipped UPS



EAGLE WOODWORKING
678 Andover St. #1, Lawrence, MA 01843-1033
FAX (978) 681-6197 (800) 628-4849



Furnituremaking
Workshops

*Small, hands-on classes
Masterful instruction*

1774 W. Lunt Avenue
Chicago, IL 60626
773.761.3311

Jeff Miller, director
www.furnituremaking.com



WINDSOR CHAIR CLASSES
One-week intensive class
Lodging and meals included
*See our website for more
woodworking classes*
chairwright.com 309-283-1831

WOODJOY® TOOLS
Master Spokeshave
See FWW #185, pg 69



**AUTHOR'S
BEST OVERALL
CHOICE**

508-669-5245
woodjoytools.com



CROWN PLANE COMPANY
TRADITIONAL BENCH MADE PLANES
*JACK...SMOOTH...SCRUB...SCRAPERS...BLOCK
CHAIRMAKERS TRAVISHERS...COMPASS PLANES*
18 Chase Street South Portland, ME 04106
(207) 799-7535
Order Online www.crownplane.com

**Ernie Conover, America's
preeminent instructor, will
teach you to build fine furniture!**

www.conoverworkshops.com
ph440.548.3491



**CONOVER
WORKSHOPS**

Since 1980

PO Box 679
Parkman, OH 44080

Educating America's Craftspeople

IMPORTING FINE QUALITY HAND TOOLS



PECK TOOL
SUPERIOR QUALITY SINCE 1929

SHOP ONLINE AT WWW.PECKTOOL.COM



**WINDSOR CHAIR
WORKSHOPS**
*Courses teaching a variety of styles
offered throughout the year.*
Call for Class Schedules
Jim Rendi, Tel: 610-689-4717
www.philadelphia-windsor-chair-shop.com

INDEX TO ADVERTISERS

ADVERTISER	web address	page #	ADVERTISER	web address	page #
Amana Tool Company	www.amanatool.com	p. 15	J. W. Winco	www.jwwinco.com	p. 110
Berkshire Veneer Co.	www.berkshireveneer.com	p. 15	Keller & Company	www.kellerdovetail.com	p. 17
Blue Spruce Toolworks	www.bluesprucetoolworks.com	p. 110	Klingspor's Woodworking Shop	www.woodworkingshop.com	p. 17
Blum Tool Co.	www.blumtoolco.com	p. 9	Lie-Nielsen Toolworks	www.lie-nielsen.com	p. 13
Center for Furniture Craftsmanship	www.woodschoool.org	p. 9	Lignomat Moisture Meters	www.lignomat.com	p. 9
The Chair Wright	www.chairwright.com	p. 111	Makers-Marks	www.makers-marks.co.uk	p. 110
Classic Designs by Matthew Burak	www.tablelegs.com	p. 15	Minwax	www.minwax.com	p. 7
Connecticut Valley School of Woodworking	www.schoolofwoodworking.com	p. 110	New England School of Architectural Woodworking	www.nesaw.com	p. 110
Conover Workshops	www.conoverworkshops.com	p. 111	Noden Adjust-A-Bench	www.adjustabench.com	p. 110
Cook Woods	www.cookwoods.com	p. 17	North Bennet Street School	www.nbss.org	p. 17
The Craftsman Gallery	www.chipsfly.com	p. 110	Old English Academy of Fine Woodworking	www.oefcc.com	p. 110
Crown Plane Co.	www.crownplane.com	p. 111	Osborne Wood Products	www.woodencomponents.com	p. 13
Curious Woods	www.curiouswoods.com	p. 13	Peck Tool Company	www.pecktool.com	p. 111
Delta Machinery	www.deltamachinery.com/ contractor	p. 2-3	Philadelphia Furniture Workshop	www.philadelphiafurnitureworkshop.com	p. 110
Eagle America	www.eagleamerica.com	p. 11	Philadelphia Windsor Chair Shop	www.philadelphia-windsor-chair-shop.com	p. 111
Eagle Woodworking		p. 111	Router Bits.com	www.routerbits.com	p. 17
Fine Homebuilding.com	www.finehomebuilding.com	p. 12	Scherr's Cabinet & Doors, Inc.	www.scherrs.com	p. 17
Fine Woodworking.com	www.finewoodworking.com	p. 113	School of Woodworking	www.cfeeschool.com	p. 110
Forrest Manufacturing	www.forrestblades.com	p. 17	Shaker Workshops	www.shakerworkshops.com/fw	p. 9
Furnituremaking Workshops	www.furnituremaking.com	p. 111	Titebond Wood Glue	www.titebond.com	p. 11
General Manufacturing Co., Ltd	www.general.ca	p. 13	Woodcraft	www.woodcraft.com	p. 115
Gorilla Glue	www.gorillaglu.com	p. 15	Woodjoy Tools	www.woodjoytools.com	p. 111
Hibdon Hardwood, Inc.	www.hibdonhardwood.com	p. 110	Woodworkers Source	www.exoticwoods.net	p. 111
Highland Woodworking	www.highlandwoodworking.com	p. 110			
Horton Brasses	www.horton-brasses.com	p. 9			
Inside Passage School of Woodworking	www.insidepassage.com	p. 15			

Breadboard-end basics

Q: What's the purpose behind using breadboard ends on a tabletop?

—PAT HOUGHTON, Shreveport, La.

A: BREADBOARD ENDS KEEP WIDE TABLE ENDS FLAT while allowing the top to move seasonally. The breadboard is a grooved end cap that is placed over tenons and secured with pins. It is joined to the tabletop with a series of tenons connected by a continuous stub tenon. The longer tenons (usually three or five but always odd in number) offer support when lifting the table by its ends. The short stub tenon helps minimize cupping along the width of the tabletop.

The breadboard is glued only in the center, which allows the top to expand or contract independently from the breadboard. The breadboard is further secured with pegs through the tenons.

The outer peg holes and outer mortises must be elongated to allow for movement. The easiest way to do this is to dry-fit the breadboard to

DESIGNING TRADITIONAL BREADBOARD ENDS

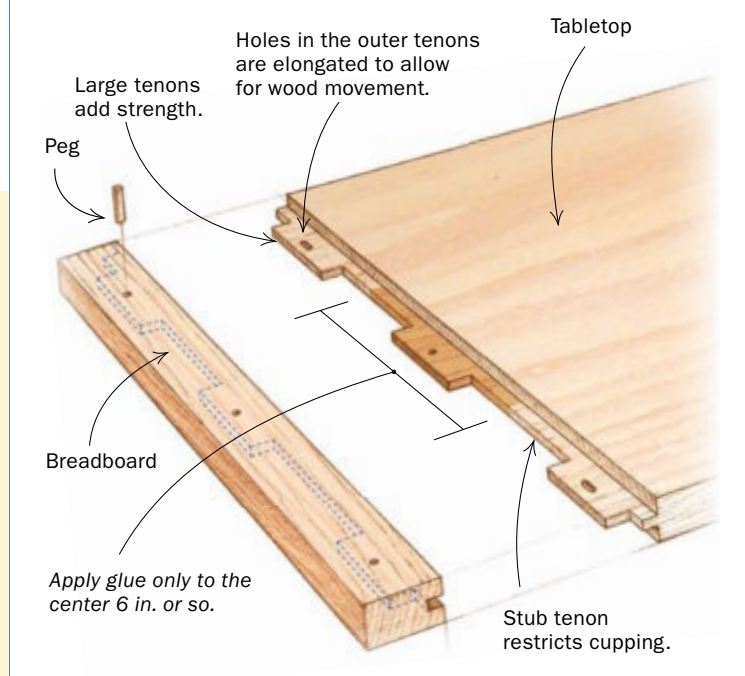

the top and drill for the pegs. Then remove the breadboard and elongate the holes in the tenons with a file before gluing and pegging the breadboard in place.

—Michael Pekovich, Fine Woodworking's art director, has been building furniture for 20 years.

Dovetail size and spacing

Q: How should I space my dovetails? I have seen examples from different eras and various furniture makers that exhibit various proportions. Is there a right way?

—WILLIAM DONOVAN, Altoona, Pa.



A: ON EARLY PIECES OF FURNITURE, you often will see pins and tails close to the same size and with steep angles. As furniture making evolved in this country, pins became smaller and the angles less acute.

Generally, narrow pins are considered the finest work. They showcase a maker's skill and create a refined look that draws the eye.

Evenly spaced dovetails are the easiest to lay out using a couple tricks. One is the half rule (see top drawing, right). With this method, you place half-pins at the edges of the board, find the center point between them, and locate a pin there. Keep dividing the spaces in half

to locate pins. In a typical drawer, you'll want at least three full pins and two half-pins (one at each edge). In a case, you'll want a pin spaced every 2 in. to 2½ in.

You also can use a rule to create evenly spaced dovetails. First, decide on the number of pins. Angle the rule until that number is aligned with the far edge. For example, say you want 10 pins on an 8-in. board. Angle the rule until the 10-in. mark aligns with the edge, then make marks at every inch. Transfer those marks to the end of the board, creating 10 evenly spaced pins.

—Philip C. Lowe runs The Furniture Institute of Massachusetts.

EVENLY SPACED DOVETAILS

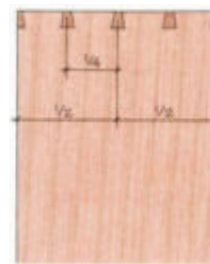

THE HALF RULE

To get an even number of spaces, divide the overall width in half, then halve the spaces again as needed. With practice, this method can be done by eye.



THE ANGLED RULE

Another trick is to angle a rule until the appropriate number of increments line up with the edges of the board. This method will deliver an even or odd number of divisions.

Fine
WoodWorking.com



INSTANT ANSWERS A CLICK AWAY

Over 1,300 articles

250+ skill-building videos

Over 200 furniture projects

Over 500 side-by-side
tool comparisons

Fully indexed,
searchable archive

Expert help for every skill level

Get instant access to the most dynamic woodworking site online. Our award-winning site is the perfect complement to *Fine Woodworking* magazine.

It's always worth exploring FineWoodworking.com, because we add new content every weekday. Here you'll discover fresh, new ideas and know-how to inspire, instruct, and answer your questions.

And all of it is just a click away!



Take a look right now!
Explore **FineWoodworking.com/New**



The Taunton Press

© 2007 The Taunton Press

Single tenon for a wide apron?

Q: I'm building a hall table with a large drawer (for a District of Columbia phone directory). The apron is 7 in. wide with mortise-and-tenon joints where it meets the legs. Will a single tenon make the apron crack?

—BILL LINDAU,
Vilas, N.C.

A: AFTER MULLING OVER THE INTENDED PURPOSE OF THE TABLE and the heavy duty it will likely serve, I recommend a double crenellated tenon: two large tenons with a shorter stub tenon in between.

One of the large tenons should be a bit loose in its mortise, allowing it and the full width of the apron or panel to move. In a table apron, the top tenon should be tight with the lower tenon loose, so that movement is directed away from the tabletop. For a 7-in.-wide apron, make the tenons about 1¾ in. wide each with a ½-in. haunch at the top and a ¼-in. shoulder at the bottom. This leaves 2¾ in. for the central stub portion. Leave about ⅛ in. of space in the lower mortise to allow the tenon to move.

—Mario Rodriguez teaches woodworking at workshops around the country.

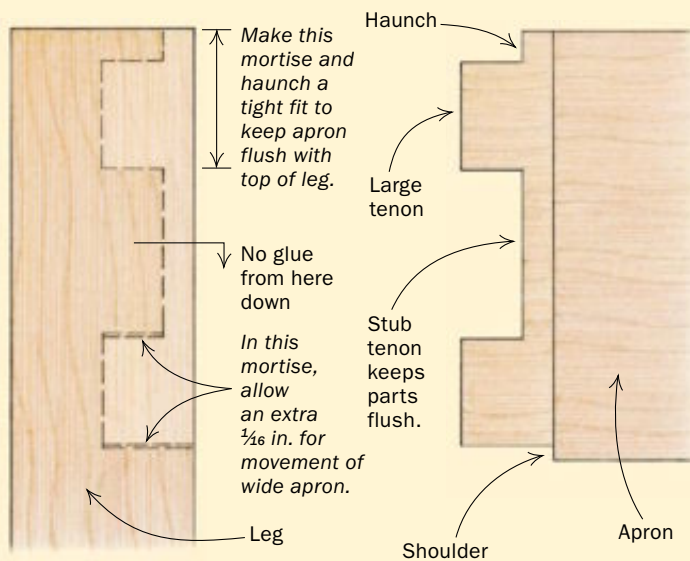

Choosing a secondary wood

Q: I plan to build a desk with mahogany as the primary wood. I have noticed that a lot of traditional cabinets use poplar as a secondary wood, but I prefer the look of maple. Which is a better choice?

—DAVE BROWN,
San Francisco

A: SECONDARY WOODS USED IN PERIOD FURNITURE typically were local woods, so they vary from region to region. Poplar often is less expensive than maple, and it's easier to use because it is softer. These concerns influenced woodworkers in the past, and they still do today.

However, if you are willing to do the extra work and pay the difference, there is no reason why you should not use maple as a secondary wood.

—Chairmaker Mike Dunbar runs
The Windsor Institute in New Hampshire.

Are glued legs OK?

Q: I plan to build a large, end-grain butcher-block table out of maple. I've been told that legs made from 16/4 stock would be better than glued-up legs from 8/4 stock. However, I am having no luck finding 16/4 maple nearby. On the other hand, 8/4 maple is readily available. It's not quartersawn, but it is dry and stable. I'm inclined to glue up this 8/4 stock for the legs and hope for the best. What do you think?

—OLAF GERHARDT, New York, N.Y.

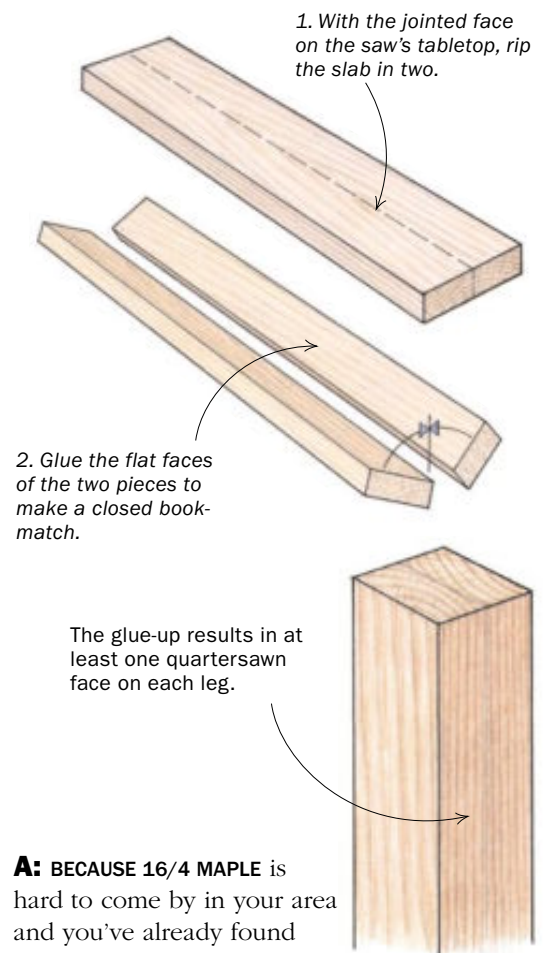

A: BECAUSE 16/4 MAPLE is hard to come by in your area and you've already found 8/4 stock, go for it.

If your 8/4 stock is 8 in. or wider, I would flatten one face, rip it down the middle, and reglue the faces. Because the 8/4 stock is most likely flatsawn, regluing, like a closed book-match, will result in at least one very nice quartersawn face on each leg. Also, if the grain is relatively straight, the glue line will be hardly noticeable.

—Christian Becksvoort is a contributing editor to Fine Woodworking.



WOODCRAFT[®]
Helping You Make Wood Work[®]

For A Free Catalog Or To Find Your Local Woodcraft Store, Visit www.woodcraft.com Or Call 800-542-9115.

"10 Essential Router Bits"!

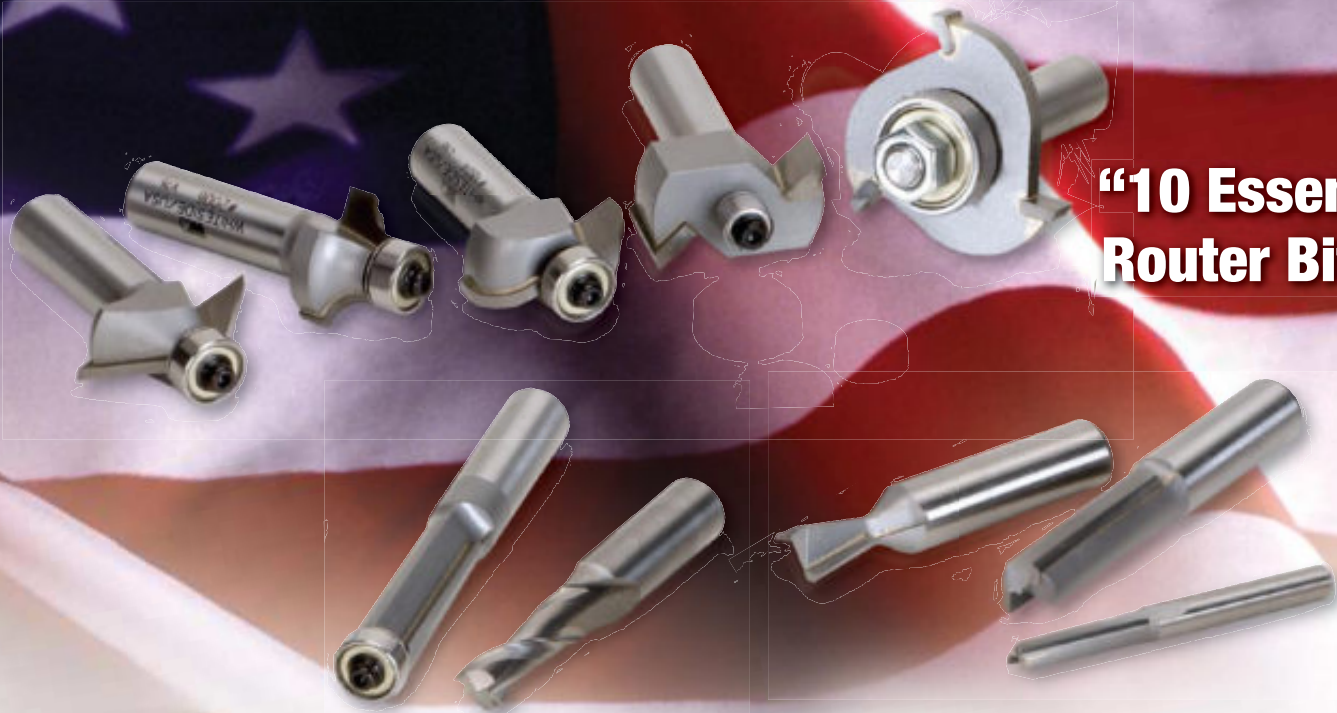

- Made from solid alloy steel
- Precision ground for proper balance at high rpms
- Uses the highest quality American made micrograin carbide
- High hook and relief angles make for better chip ejection
- Made with thick carbide for extra sharpenings
- Superior edge quality compared to other manufacturers
- Made with only high quality American made grinding wheels

"American Made for the American Woodworker"

Author's Choice – BEST OVERALL* and Author's Choice – BEST VALUE* in an 18 bit road-test evaluation by Fine Woodworking Magazine, June 2007

***** Bit #3212***



WA
WHITESIDE

Dept: 07WW07P

QUALITY WOODWORKING TOOLS • SUPPLIES • ADVICE™

building furniture

THE BEST OF *Fine Woodworking*

- Understand basic anatomy
- Learn time-tested strategies
- Build furniture in any style

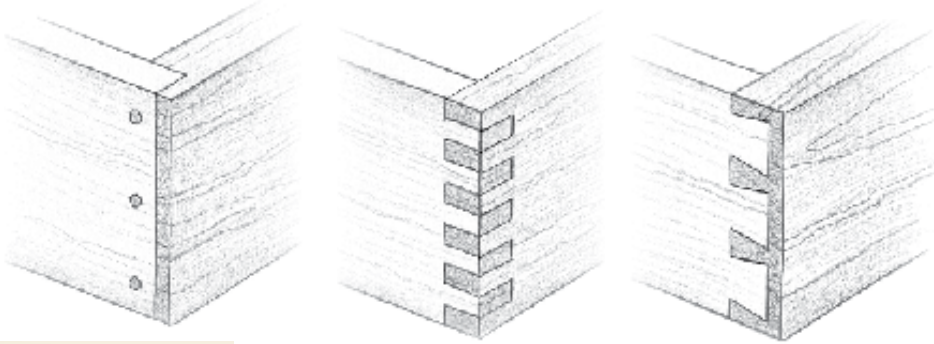

Drawer design, p. 78



Sturdy table joints, p. 34

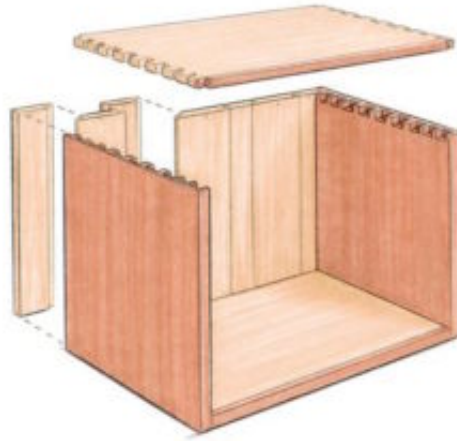

Chest of drawers, p. 62

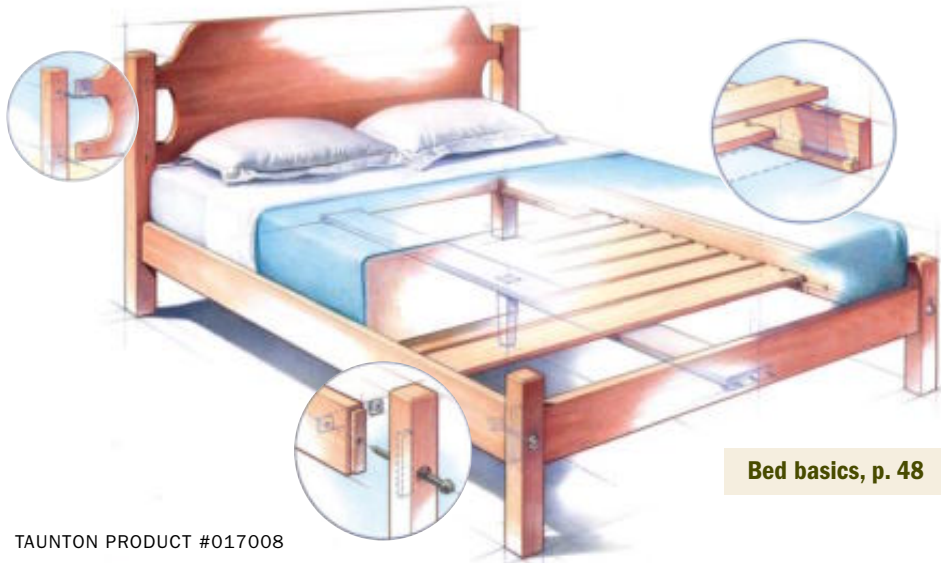

Bed basics, p. 48

TAUNTON PRODUCT #017008



Bookcases, p. 18

Tables with drawers, p. 42

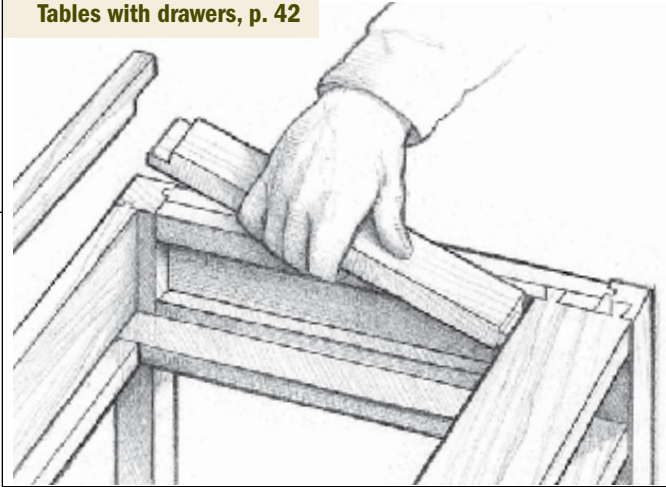
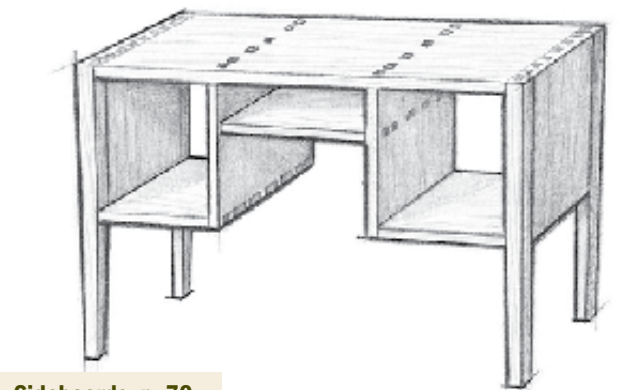
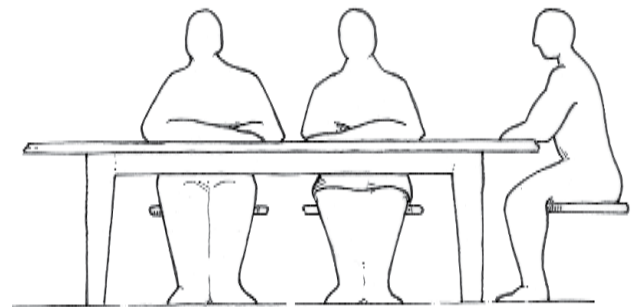

Table design, p. 30



Sideboards, p. 70