

CONTENTS

IMPORTANT SAFEGUARDS	7
SAVE THESE INSTRUCTIONS	7
SHORT CORD INSTRUCTIONS	7
INTRODUCTION	8
Symbols used in these instructions	8
Troubleshooting and repairs	8
DESCRIPTION	8
Description of the appliance	8
PRELIMINARY CHECKS	9
Checking the appliance	9
Installing the appliance	9
TURNING THE APPLIANCE ON	10
TURNING THE APPLIANCE OFF	10
SETTING WATER HARDNESS	10
Measuring water hardness.....	10
Setting water hardness	10
Default values (reset).....	10
MAKING COFFEE	11
Selecting the coffee taste.....	11
Selecting the coffee	11
2-cups or double size	11
Adjusting the coffee mill	11
Tips for a hotter coffee	11
Making coffee using coffee beans	11
Making coffee using pre-ground coffee	12
MAKING DRINKS WITH MILK	12
Filling and attaching the milk container	12
Adjusting the froth.....	12
Making drinks with milk automatically.....	12
Cleaning the milk container after use	12
DELIVERING HOT WATER	13
Delivering hot water	13
CLEANING	13
Cleaning the coffee grounds container.....	13
Cleaning the drip tray and condensate tray.....	13
Cleaning the inside of the coffee maker	13
Cleaning the water tank.....	13
Cleaning the coffee spouts	14
Cleaning the pre-ground coffee funnel	14
Cleaning the infuser	14
Cleaning the milk container	14
Cleaning the hot water/steam nozzle	14
DESCALE	14
WATER SOFTENER FILTER (IF FITTED)	15
Installing the filter	15
TECHNICAL SPECIFICATION	16
EXPLANATION OF LIGHTS	16
TROUBLESHOOTING	19
LIMITED WARRANTY	20
What does the warranty cover?	20
How long does the coverage last?	20
What is not covered by the warranty?	20
How do you get service?	20
How does country law apply?	20

IMPORTANT SAFEGUARDS

When using electrical appliances, basic safety precautions should always be followed, including the following.

- Read all instructions carefully.
- Make sure the voltage of your electrical system corresponds to the voltage shown on the bottom of the machine.
- Do not touch hot surfaces. Use handles or knobs.
- To protect against fire, electrical shock and personal injury, do not immerse cord, plug or appliance in water or other liquid.
- Keep the appliance out of the reach of children and do not leave appliance unattended while in operation.
- Unplug from the outlet when not in use and before cleaning.
- Do not operate with a damaged cord or plug, or after the appliance malfunctions, or has been damaged in any manner. Return the appliance to the nearest authorized service facility for examination, repair or adjustment.
- The use of accessory attachments not recommended by the manufacturer may result in fire, electrical shock, or personal injury.
- Do not use outdoors.
- Make sure the power cord does not hang over the edge of the table or counter-top to avoid getting accidentally caught or entangled.
- Do not place the appliance or its electrical parts on or near electric stoves, cooking surfaces, or gas burners.
- Plug cord into the wall outlet. To disconnect, first turn machine "off", then remove plug from wall outlet.
- Do not use the appliance for other than the intended use. This appliance is to be utilized for domestic use only. The manufacturer declines all responsibility for any damage caused by improper, incorrect, or irresponsible use.

WARNING: To reduce the risk of fire or electric shock, do not remove the cover or the exterior of the unit. Don't attempt to repair or modify the machine, doing so will void the warranty. Repair should be done by authorized service personnel only!

SAVE THESE INSTRUCTIONS

THIS APPLIANCE IS FOR HOUSEHOLD USE ONLY

SHORT CORD INSTRUCTIONS

- A short power cord is provided to reduce risks resulting from becoming entangled in or tripping over a longer cord.
- Longer, detachable power supply cords or extension cords are available and may be used if care is exercised in their use.
- If an extension cord is used, the marked electrical rating should be at least as great as the electrical rating of the appliance. If the appliance is provided with 3- wire, grounding type cord, the extension should be a GROUNDING TYPE 3 - WIRE CORD. The longer cord should be arranged so that it will not drape over the counter-top or table top where it can be pulled on by children or tripped over.
- Your product is equipped with a polarized alternating current line plug (a plug having one blade wider than the other). This plug will fit into the power outlet only one way. This is a safety feature. If you are unable to insert the plug fully into the outlet, try reversing the plug. If the plug should still fail to fit, contact your electrician to replace your obsolete outlet. Do not defeat the safety purpose of the polarized plug.

INTRODUCTION

Thank you for choosing the ECAM23.260 automatic coffee and cappuccino maker.

We hope you enjoy using your new appliance.

Take a few minutes to read these instructions.

This will avoid all risks and damage to the machine.

Symbols used in these instructions

Important warnings are identified by these symbols.

It is vitally important to observe these warnings.



Danger!

Failure to observe the warning could result in life threatening injury from electric shock.



Important!

Failure to observe the warning could result in injury or damage to the appliance.



Danger of burns!

Failure to observe the warning could result in scalds.



Please note:

This symbol identifies important advice or information for the user.

Letters in brackets

The letters in brackets refer to the legend in the Description of the Appliance on page 3.

Troubleshooting and repairs

In the event of problems, first try and resolve them following the information given in the section "Explanation of lights" on page 16 and "Troubleshooting" on page 19.

If this does not resolve the problem or you require further information, you should consult Customer Experience by calling the number given on the annexed "Customer Experience" sheet. If your country is not among those listed on the sheet, call the number given in the guarantee.

If repairs are required, contact De'Longhi Customer Experience only.

Contact details are given in the guarantee certificate provided with the appliance.

Video available on

www.youtube.com/delonghiosa

DESCRIPTION

Description of the appliance

(page 3 - A)

- A1. Grinding adjustment dial
- A2. Beans container
- A3. Beans container lid
- A4. Pre-ground coffee funnel lid
- A5. Pre-ground coffee funnel
- A6. Cup shelf
- A7. Main switch
- A8. Infuser door
- A9. Infuser
- A10. Water tank lid
- A11. Water tank
- A12. Drip tray
- A13. Drip tray water level indicator
- A14. Cup tray
- A15. Coffee grounds container
- A16. Condensate tray
- A17. Coffee spout (adjustable height)
- A18. Hot water and steam nozzle

Description of the lights







(page 2 - B)

(for the meaning of the pilot lights, refer to "Explanation of lights")

- B1. **2x**: double size selected
- B2. : pre-ground coffee selected
- B3. : mild taste selected
- B4. : standard taste selected
- B5. : strong taste selected
- B6. : "Espresso" selected
- B7. : "Coffee" selected
- B8. : "Long" selected
- B9. : "Cappuccino" selected
- B10. : "Latte macchiato" selected
- B11. : "Hot water" selected
- B12. : "See instruction booklet"
- B13. : Steady: "Empty grounds container"
Blinking: "Insert grounds container"
- B14. : Steady: "Fill water tank"
Blinking: "Insert water tank"
- B15. : "Descaling is required"
- B16. : "Insert milk jug"
- B17. : "Clean the milk frother"
- B18. : "Please wait"
- B19. : "Fill beans container"
- B20. : "General alarm"
- B21. : "Exit the menu"
- B22. : "Confirm"

Description of the control panel

(page 2 - C)

- C1.  button: turns the appliance on and off (standby)
- C2.  button: to select the coffee taste
- C3.  button: to perform a rinse
- C4.  button: to select double size
- C5.  button: to start descaling
- C6.  button: to start delivery
- C7. "Select drink" knob

Description of the milk jug

(page 2 - D)

- D1. Froth and CLEAN dial
- D2. Frothed milk spout (adjustable)
- D3. Milk intake tube
- D4. Milk container

Description of the accessories

(page 2 - E)

- E1. Pre-ground coffee measure
- E2. Cleaning brush
- E3. Hot water spout
- E4. Water softener filter (*certain models only)
- E5. "Total Hardness Test" indicator paper
- E6. Descaler

PRELIMINARY CHECKS

Checking the appliance

After removing the packaging, make sure the product is complete and undamaged and that all accessories are present.

Do not use the appliance if it is visibly damaged.

Contact De'Longhi Customer Experience.

Installing the appliance



Important!

When installing the appliance, respect the following safety warnings:

- The appliance gives off heat.
After positioning the appliance on the worktop, leave a space of at least 1.18 in / 3 cm between the surfaces of the appliance and the side and rear walls and at least 5.9 in/ 15 cm above the coffee maker.
- Water penetrating the coffee maker could cause damage.
Do not place the appliance near taps or sinks.
- The appliance could be damaged if the water it contains freezes.
Do not install the appliance in a room where the temperature could drop below freezing point.

- Arrange the power cable in such a way that it cannot be damaged by sharp edges or contact with hot surfaces (e.g. electric hot plates).

Connecting the appliance



Important!

Check that the mains power supply voltage corresponds to the value indicated on the rating plate on the bottom of the appliance.

If the power socket does not match the plug on the appliance, have the socket replaced with a suitable type by a qualified professional.



Using the appliance for the first time



Please note!

- Coffee has been used to factory test the appliance and it is therefore completely normal for there to be traces of coffee in the mill.
The machine is, however, guaranteed to be new.
- You should customise water hardness as soon as possible following the instructions in the section "Setting water hardness" (page 10).

Follow the instructions:

1. Remove the water tank, fill to the MAX line with fresh water (fig. 1A) then put back in the appliance (fig. 1B).
2. Check that the hot water spout is inserted on the nozzle and place a container (fig. 2) with a minimum capacity of 100 ml underneath.
3. Plug the appliance into the mains socket and press the main switch (fig. 3).
4. The  and the  lights turn on (fig. 4).
5. Press the  button: the appliance delivers water from the hot water spout then goes off.
6. The appliance automatically switches off.

The coffee maker is now ready for normal use.



Please note!

- When using the appliance for the first time, you need to make 4-5 cups of coffee or 4-5 cappuccinos before the appliance starts to give satisfactory results.
- To enjoy your coffee even more and improve the performance of your appliance, we recommend installing a water softener filter as described in the section "WATER SOFTENER FILTER" (page 15). If your model is not provided with a filter, you can request one from De'Longhi Customer Services.

TURNING THE APPLIANCE ON

Please note!

Before turning the appliance on, make sure the main switch is pressed (fig. 3).



Each time the appliance is turned on, it performs an automatic preheat and rinse cycle which cannot be interrupted.

The appliance is ready for use only after completion of this cycle.

Danger of burns!

During rinsing, a little hot water comes out of the coffee spouts and is collected in the drip tray underneath.

Avoid contact with splashes of water.

- To turn the appliance on, press the  button (fig. 5).  flashes to indicate that the appliance is heating up and performing an automatic rinse cycle (by circulating hot water, the appliance heats both the boiler and the internal circuits).

The appliance is at temperature when the  light goes off and the lights corresponding to the coffee taste and beverages come on.

TURNING THE APPLIANCE OFF

Whenever the coffee machine is turned off after being used to make coffee, it performs an automatic rinse cycle.

Danger of burns!

During rinsing, a little hot water flows from the coffee spouts.

Avoid contact with splashes of water.

To turn the appliance off (standby), press the  button (fig. 5). The appliance performs a rinse cycle, then goes off.

Please note!

If the appliance is not used for an extended period, switch off the machine at the main switch.

- first turn the appliance off by pressing the  button (fig. 5);
- release the main switch at the side of the appliance (fig. 3).

Important!

Never press the main switch while the appliance is on.

SETTING WATER HARDNESS

The  (descaling) light turns on after a period of time according to water hardness.

The machine is factory set for a hardness value of 4.





The machine can also be programmed according to the hardness of the mains water in the various regions so that the machine needs to be descaled less often.









Measuring water hardness





- Remove the "total hardness test" indicator paper attached to this manual from its pack.

- Immerse the paper completely in a glass of water for one second.
- Remove the paper from the water and shake lightly. After about a minute, 1, 2, 3, or 4 red squares form, depending on the hardness of the water. Each square corresponds to one level.

Setting water hardness

- With the machine on, keep pressed the  button for about six seconds until  lights on:  and  flash.
- Turn the knob until the required level is selected:

Turn knob	Select level	Corresponding water hardness test
	Soft water 	
	Slightly hard water 	
	Hard water 	
	Very hard water 	

- Press the  button to confirm: the  light turns on to indicate that the appliance is saving the new setting. (If you want to abort the new setting, press the  button, corresponding to .

The machine is now reprogrammed with the new water hardness setting.



Default values (reset)

This resets the water hardness level back to the default values.

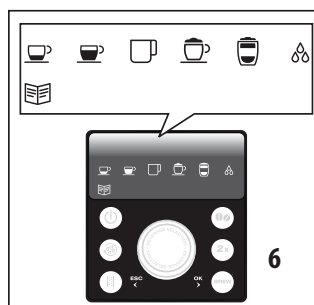

To reset the default values, proceed as follows:



- With the machine on, keep pressed the  button for about six seconds.

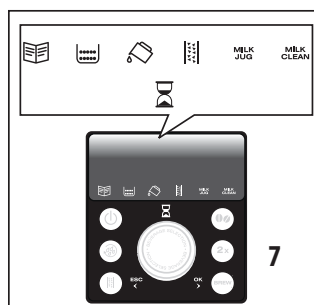

- Press again  button until the lights shown in fig. 6 come on:  and  flash.



- Press the  button to confirm: the lights shown in fig. 7 flash to indicate that the appliance is resetting the default values. (If you want to abort the operation, press the  button.)

tion, press the  button, corresponding to ^{ESC} .

MAKING COFFEE

Selecting the coffee taste

The appliance is set by default to make coffee with a standard taste.



You can also choose one of these tastes:

		
Mild taste	Standard taste	Strong taste

To change the taste, press the  button (fig. 8) repeatedly until the required taste is displayed.

Selecting the coffee

To select the coffee, turn the selection knob (fig. 9) until the light corresponding to the required quantity of coffee comes on:

Coffee selected	Quantity in cup (ml/oz)	2-cups or double size
 ESPRESSO	30ml (1oz)	Press 2x
 COFFEE	120ml (4oz)	
 LONG	120ml (4oz)	

If you want to deliver 2 cups of coffee or a double size of coffee, press the **2x** button: the corresponding light comes on.

Adjusting the coffee mill

The coffee mill is preset in the factory to make coffee correctly and should not require adjusting initially.

However, if after making the first few coffees you find that the coffee is too thin and not creamy enough or that delivery is too slow (a drop at a time), this can be corrected by adjusting the grinding adjustment dial (fig. 10).

 **Please note!**

The grinding adjustment dial must only be turned when the coffee mill is in operation.

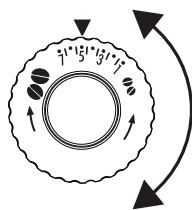

If the coffee is delivered too slowly or not at all, turn one click clockwise towards "7".

For fuller bodied creamier coffee on the other hand, turn one click anticlockwise towards "1" (do not turn more than one click at a time otherwise the coffee could

be delivered a drop at a time).

These adjustments will only be evident after at least 2 cups of coffee have been delivered.

If this adjustment does not obtain the desired result, turn the dial another click.

Tips for a hotter coffee

For a hotter coffee, before delivery you are recommended to:

- rinse the appliance through by pressing the  button. Hot water flows out of the coffee spouts and heats the internal circuit of the machine so that the coffee delivered will be hotter.

 **Danger of burns!** If inserted, hot water will flow out from the hot water spout.

- warm the cups with hot water (using the hot water function).

Making coffee using coffee beans

 **Important!**

Do not use caramelised or candied coffee beans as they could stick to the coffee mill and make it unusable.

1. Place coffee beans in the coffee bean container (fig. 11).
2. Place under the coffee dispensing spouts, either:
 - 1 cup if you want one coffee (fig. 12);
 - 2 cups if you want 2 coffees.
3. Lower the spouts as near as possible to the cup. This makes a creamier coffee (fig. 13).
4. Press the **BREW** button.
5. Preparation begins and automatically stops.

 **Please note:**

- While the machine is making coffee, delivery can be interrupted at any moment by pressing the **BREW** button.
- At the end of delivery, to increase the quantity of coffee in the cup, just press and hold (within 3 seconds) the **BREW** button.

Once the coffee has been made, the appliance is ready to make the next drink.

 **Please note!**

- Lights may be displayed on the control panel during use. Their meaning is given in the section "Explanation of the lights" on page 16.
- For hotter coffee, see the section "Tips for a hotter coffee" (page 11).
- If the coffee is delivered a drop at a time, too weak and not creamy enough or too cold, read the tips in the "Troubleshooting" section on page 19.



Making coffee using pre-ground coffee

Important!

- Never add pre-ground coffee when the machine is off or it could spread through the inside of the machine and dirty it. This could damage the appliance.
- Never use more than 1 level measure or it could dirty the inside of the coffee maker or block the funnel.

Please note!

If you use pre-ground coffee, you can only make one cup of coffee at a time (it is suggested not to require double size).

1. Keep pressed the  button (fig. 8) until  is displayed.
2. Open the pre-ground coffee funnel lid.
3. Make sure the funnel is not blocked, then add one level measure of pre-ground coffee (fig. 14).
4. Place a cup under the coffee spouts.

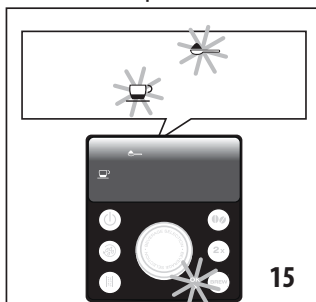

5. Press the **BREW** button: the lights shown on fig. 15 come on.
6. Press the **BREW** button to confirm: preparation begins and automatically stops.

MAKING DRINKS WITH MILK

Please note!

- To avoid producing milk with poor froth or large bubbles, always clean the milk container lid as described in the section "Cleaning the milk container" on pages 12 and 14.

Filling and attaching the milk container

1. Remove the lid (fig. 16);
2. Fill the milk container with a sufficient quantity of milk, not exceeding the MAX level marked on the container (fig. 17). Each mark on the side of the container corresponds to 100 ml of milk.

Please note!

For a denser more even froth, you should use skimmed or partially skimmed milk at refrigerator temperature (about 5°C).

3. Make sure the milk intake tube is correctly inserted in the bottom of the milk container lid (fig. 18).
4. Place the lid back on the milk container.
5. Remove the hot water spout from the nozzle.
6. Attach the container to the nozzle and push as far as it will go (fig. 19).

7. Place a sufficiently large cup under the coffee and frothed milk spouts. Adjust the length of the milk spout. To move it nearer the cup, simply pull it downwards (fig. 20).
8. Follow the instructions below for each function.



Adjusting the froth

Check that the froth adjustment dial on the milk container lid is on .

Making drinks with milk automatically

CAPPUCCINO and LATTE MACCHIATO can be prepared automatically.

Proceed as follows:

1. Fill the milk container and attach it as described above.
2. Turn the selection knob (fig. 9) until the light corresponding to the required milk beverage comes on:
: "Cappuccino";
: "Latte macchiato".
3. If you want to deliver a double size, press the **2x** button: the corresponding light comes on.
4. Press the **BREW** button.
5. After a few seconds, frothed milk is delivered from the milk spout into the cup below. The machine automatically makes the coffee after delivering the milk.

Please note!

- If during delivery you want to stop preparation, press the **BREW** button.
- At the end of delivery, to increase the quantity of milk or coffee in the cup, just press and hold (within 3 seconds) the **BREW** button.
- Do not leave the milk container out of the refrigerator for long periods. The warmer the milk (5°C is ideal), the poorer the quality of froth produced.

Cleaning the milk container after use

Important! Danger of burns

When cleaning the internal tubes of the milk container, a little hot water and steam leak out of the frothed milk spout. Avoid contact with splashes of water.

 lights on the display each time you use a milk function. To eliminate all milk residues, proceed as follows:

1. Leave the milk container in the machine (you do not need to empty it);
2. Place a cup or other recipient under the frothed milk spout.
3. Turn the froth adjustment dial to "CLEAN" (fig. 21).
4. Press the **BREW** button to confirm.
5. Cleaning starts and stops automatically.
6. Turn the dial back to one of the froth selections.

- Remove the milk container and always clean the steam connection nozzle with a sponge (see fig. 22).

 **Please note!**

- To prepare a number of milk based coffees, clean the milk container after you have prepared the last drink only.
- The milk container can be kept in the refrigerator.

DELIVERING HOT WATER

 **Important! Danger of burns.**

Never leave the machine unsupervised while delivering hot water or steam.

The spout becomes hot during delivery. Hold by the handle only.

Delivering hot water

- Make sure the hot water spout is attached correctly (fig. 2).
- Place a container under the spout (as close as possible to avoid splashes).
- Turn the selection knob (fig. 9) until the  light comes on.
- If you want to deliver a double size, press the **2x** button: the corresponding light comes on.
- Press the **BREW** button.
- The machine delivers hot water, then stops automatically. To interrupt delivery of hot water manually, press the **BREW** button again.

CLEANING

 **Important!**

- Do not use solvents, abrasive detergents or alcohol to clean the coffee maker.
With De'Longhi bean to cup coffee makers, you need not use chemical products to clean the machine.
- None of the components can be washed in a dishwasher apart from the milk container (D).
- Do not use metal objects to remove encrustations or coffee deposits as they could scratch metal or plastic surfaces.

Cleaning the coffee grounds container

When  comes on, the grounds container must be emptied and cleaned.

Until the grounds container has been cleaned, the appliance continues to display the message and coffee cannot be made.

 **Important! Danger of burns**

If you make a number of cappuccinos one after the other, the metal cup tray becomes hot.

Wait for it to cool down before touching it and handle it from the front only.

To clean (with the machine on):

- Remove the drip tray (fig. 23), empty and clean.
- Empty the grounds container and clean thoroughly to remove all residues left on the bottom. This can be done with the spatula on the brush provided.
- Check the condensate tray (red) and empty if necessary.

 **Important!**

When removing the drip tray, the grounds container must be emptied, even if it contains few grounds.

If this is not done, when you make the next coffees, the grounds container may fill up more than expected and clog the machine.

Cleaning the drip tray and condensate tray

 **Important!**

The drip tray is fitted with a level indicator (red) showing the level of water it contains (fig. 24).

Before the indicator protrudes from the cup tray, the drip tray must be emptied and cleaned, otherwise the water may overflow the edge and damage the appliance, the surface it rests on or the surrounding area.

To remove the drip tray:

- Remove the drip tray and the grounds container (fig. 23);
- Empty the drip tray and grounds container and wash them;
- Check the red condensate tray and empty if necessary.
- Replace the drip tray and grounds container.

Cleaning the inside of the coffee maker

 **Danger of electric shock!**

Before cleaning internal parts, the machine must be turned off (see "Turning off") and unplugged from the mains power supply.

Never immerse the coffee maker in water.

- Check regularly (about once a month) that the inside of the appliance (accessible after removing the drip tray) is not dirty. If necessary, remove coffee deposits with the brush provided or a sponge.
- Remove the residues with a vacuum cleaner (fig. 25).

Cleaning the water tank

- Clean the water tank (A11) regularly (about once a month and whenever you replace the water softener filter (if provided) with a damp cloth and a little mild washing up liquid.
- Remove the filter (if present) and rinse with running water.
- Replace the filter (if provided), fill the tank with fresh water and replace the tank.

Cleaning the coffee spouts

1. Regularly clean the coffee spouts with a sponge or cloth (fig. 26A).
2. Check the holes in the coffee spout are not blocked. If necessary, remove coffee deposits with a toothpick (fig. 26B).

Cleaning the pre-ground coffee funnel

Check regularly (about once a month) that the pre-ground coffee funnel (A5) is not blocked. If necessary, remove coffee deposits with the brush (E2) supplied.

Cleaning the infuser

The infuser (A9) must be cleaned at least once a month.



Important!

The infuser may not be extracted when the machine is on.

1. Make sure the machine is correctly turned off (see "Turning the appliance off" on page 10).
2. Remove the water tank.
3. Open the infuser door (fig. 27) on the right side.
4. Press the two red release buttons inwards and at the same time pull the infuser outwards (fig. 28).
5. Soak the infuser in water for about 5 minutes, then rinse under the tap.



Important!

RINSE WITH WATER ONLY

NO WASHING UP LIQUID - NO DISH WASHER

Clean the infuser without using washing up liquid as it could be damaged.

6. Use the brush (E2) to remove any coffee residues left in the infuser housing, visible through the infuser door.
7. After cleaning, replace the infuser by sliding it onto the internal support; then push the PUSH symbol fully in until it clicks into place (fig. 29).



Please note!

If the infuser is difficult to insert, before insertion, adapt it to the right size by pressing the two levers shown in fig. 30.

8. Once inserted, make sure the two red buttons have snapped out (fig. 31).
9. Close the infuser door.
10. Replace the water tank.

Cleaning the milk container

Clean the milk container every two days as described below:

1. Remove the lid.
2. Remove the milk spout and intake tube.
3. Turn the froth adjustment dial clockwise to the "INSERT" position (fig. 32) and pull off upwards.

4. Wash all the components thoroughly with hot water and mild washing-up liquid. All components are dishwasher safe, placing them in the top basket of the dishwasher. Make sure there are no milk residues on the hollow and groove under the dial (see fig. 33). If necessary, scrape the groove with a toothpick.

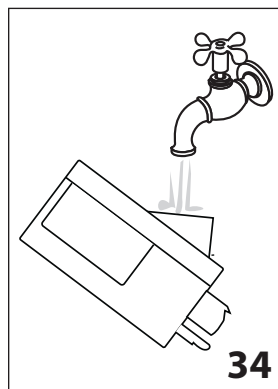

5. Rinse inside the froth adjustment dial seat with running water (fig. 34).
6. Check that the intake tube and spout are not clogged with milk residues.
7. Replace the dial (in correspondence to the word "INSERT"), spout and milk intake tube.
8. Place the lid back on the milk container.

Cleaning the hot water/steam nozzle

Each time you prepare milk, clean the nozzle with a sponge to remove milk residues from the gaskets (see fig. 22).

DESCALE

Descale the machine when  appears on the display.



Important!

- Descaler contains acids which may irritate the skin and eyes. It is vital to respect the manufacturer's safety warnings given on the descaler pack and the warnings relating to the procedure to follow in the event of contact with the skin and eyes.
- You should use De'Longhi descaler only. Using unsuitable descaler and/or performing descaling incorrectly may result in faults not covered by the manufacturer's guarantee.

1. Turn the machine on.
2. Empty the water tank (A11) and remove the softener filter, if present.

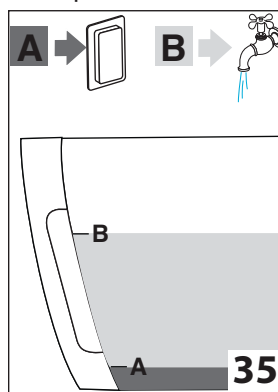

3. Pour the descaler into the tank up to the level A (corresponding to a 3.4oz/100ml pack) marked on the back of the tank (fig. 35A), then add water (1liter) up to level B (fig. 35B).

Place an empty container with a minimum capacity of 50 oz./ 1.5 liters under the water spout.

- Wait until the appliance is ready for use.



Important! Danger of burns

Hot water containing acid flows from the spout. Avoid contact with splashes of water.

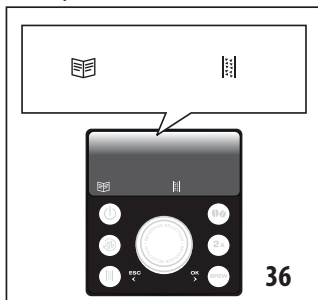

- Press the button: the lights shown in fig. 36 come on: and flash.

- Press the **BREW** button to confirm. (If you want to abort the operation, press the button, corresponding to .

- Press the **BREW** button to confirm. The descaling programme starts and the descaler liquid comes out of the cappuccino maker.

The descale programme automatically performs a series of rinses and pauses to remove limescale deposits from inside the machine. The descale programme starts and the descaler liquid comes out of the water spout.

After about 20 minutes, the , and lights come on.

- The appliance is now ready for rinsing through with clean water. Extract the water tank, empty, rinse under running water, fill with clean water up to the MAX level, insert the filter (if removed previously) and put the water tank back in the machine. The light comes on.

- Empty the container used to collect the descaler solution and replace it empty under the water spout.

- Press the button to start the first rinsing. Hot water flows out of the spout.

- When the water tank is completely empty, the , and lights come on.

- Extract the water tank, empty, rinse under running water, fill with clean water up to the MAX level, and put the water tank back in the machine. The light comes on.

- Press the button to start the second rinsing. Hot water flows out of the spout and coffee outlet.

- Press Ok and fill the water tank: the appliance is ready for use.



Please note!

If the descaling cycle is not completed correctly (e.g. lack of electricity) we recommend repeating the cycle.

WATER SOFTENER FILTER (IF FITTED)

Certain models are fitted with a water softener filter. If this is not the case with your model, you are recommended to purchase one from De'Longhi Customer Services.

To use the filter correctly, follow the instructions below.

Installing the filter

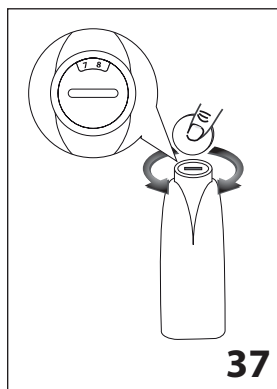

- Remove the filter from the packaging.
- Turn the date indicator disk (fig. 37) until the next two months of use are displayed.



Please note

The filter lasts about two months if the appliance is used normally. If the coffee machine is left unused with the filter installed, it will last a maximum of three weeks.

- To activate the filter, run tap water through the hole in the filter as shown in the figure until water comes out of the openings at the side for more than a minute (fig. 38).

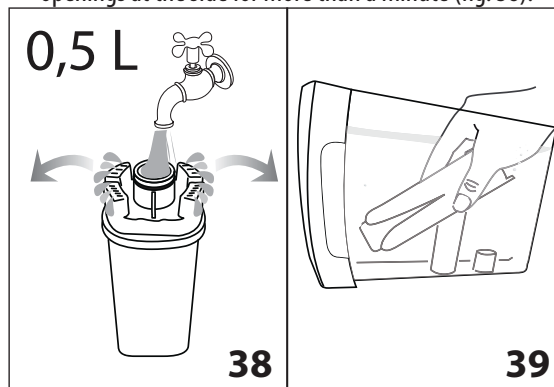

- Extract the tank from the appliance and fill with water.
- Insert the filter in the water tank and immerse it completely for about ten minutes, sloping it to enable the air bubbles to escape (fig. 39).
- Insert the filter in the filter housing and press as far as it will go (fig. 40A)
- Close the tank with the lid, then put the tank back in the machine (fig. 40B).

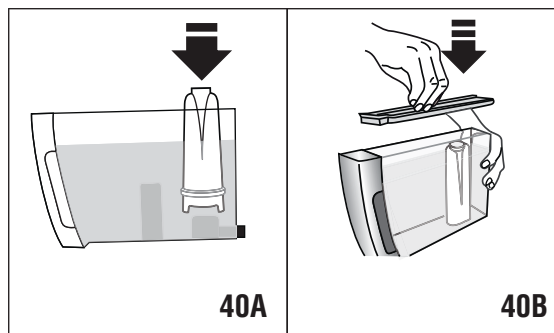

When you install the filter, it must be activated delivering hot water until it flows regularly.

! Important!









After two months (see date indicator) or when the appliance has not been used for 3 weeks, you should replace the filter with a new one, repeating the procedure for the installation.







TECHNICAL SPECIFICATION

Voltage:	120 V~ 60 Hz max. 10A
Absorbed power:	1250W
Pressure:	15 bar
Water tank capacity:	50 oz./1.5 litres max.
Size Lxhxd:	238x350x445 mm
Cable length:	1.80 m
Weight:	11.8 kg
Beans container capacity:	250 g max.

EXPLANATION OF LIGHTS

LIGHT	POSSIBLE CAUSE	REMEDY
	The appliance is heating up	Wait
	The grounds container (A15) is full	Empty the grounds container and drip tray, clean and replace. Important: when removing the drip tray, the grounds container MUST be emptied, even if it contains few grounds. If this is not done, when you make the next coffees, the grounds container may fill up more than expected and clog the machine
	After cleaning, the grounds container has not been replaced (A15)	Remove the drip tray and insert the grounds container
	The grounds container is not correctly inserted	Check that the grounds container is correctly inserted
	Insufficient water in the tank (A11)	Fill the tank with water and/or insert it correctly, pushing it as far as it will go until it clicks into place
	The water tank is not inserted	Insert the water tank
	The coffee beans have run out	Fill the beans container

	<p>The machine must be descaled.</p>	<p>The descaling procedure described in the section “Descal” needs to be performed as soon as possible</p>
	<p>The milk jug is not inserted correctly or it is not inserted at all</p>	<p>Insert the milk container as far as it will go</p>
	<p>Milk has been delivered recently and the tubes inside the milk container must be cleaned</p>	<p>Turn the froth adjustment dial to CLEAN (fig. 21)</p>
	<p>The milk frother knob (D1) is on wrong position after CLEAN</p>	<p>Turn the knob on  position</p>
	<p>The water spout is not inserted or is inserted incorrectly</p>	<p>Insert the water spout (E3) as far as it will go</p>
	<p>Water spout is required instead of milk container</p>	<p>Insert water spout</p>
	<p>General alarm</p>	<p>Contact a service center.</p>

	<p>The infuser has not been replaced after cleaning</p>	<p>Insert the infuser as described in the section "Cleaning the infuser"</p>
	<p>The grinding is too fine and the coffee is delivered too slowly or not at all</p>	<p>Repeat coffee delivery and turn the grinding adjustment knob (fig. 10) one click clockwise towards "7" while the coffee mill is in operation. If after making at least 2 coffees delivery is still too slow, repeat the correction procedure, turning the grinding adjustment knob another click until delivery is correct (see the section: Adjusting the coffee mill on page 11). If the problem persists, turn the steam knob to the I position and deliver water from the cappuccino maker.</p>
	<p>Pre-ground function was selected but no pre-ground coffee was poured</p>	<p>Pour pre-ground coffee in the coffee funnel.</p>
	<p>Pre-ground coffee is blocked in the funnel</p>	<p>Clean the preground coffee funnel (see page 14)</p>
	<p>Too much coffee has been used</p>	<p>Select a milder taste or reduce the quantity of pre-ground coffee then make the coffee again.</p>
	<p>The water circuit is empty: it is necessary to insert the water spout</p>	<p>Insert the water spout and deliver hot water</p>
	<p>The water circuit is empty</p>	<p>Press OK to deliver water from the spout (E3) until it flows out normally. If the problem persists, make sure the water tank is fully inserted.</p>

TROUBLESHOOTING

Below is a list of some of the possible malfunctions.

If the problem cannot be resolved as described, contact Customer Services.

PROBLEM	POSSIBLE CAUSE	SOLUTION
The coffee is not hot	The cups were not preheated	Warm the cups by rinsing them with hot water (N.B. you can use the hot water function)
	The infuser has cooled down because 2/3 minutes have elapsed since the last coffee was made	Before making the coffee, warm the infuser by performing a rinse (see "Tips for a hotter coffee", page 11)
The coffee is thin or not creamy enough	The coffee is ground too coarsely	Turn the grinding adjustment dial one click anti-clockwise towards "1" while the coffee mill is in operation (fig. 10). Continue one click at a time until coffee delivery is satisfactory. The effect is only visible after delivering 2 coffees (see the section: "adjusting the coffee mill" on page 11)
	The coffee is unsuitable	Use pre-ground coffee for espresso coffee makers
The coffee is delivered too slowly or a drop at a time	The coffee is ground too finely	Turn the grinding adjustment dial one click clockwise towards "7" while the coffee mill is in operation (fig. 10). Continue one click at a time until coffee delivery is satisfactory. The effect is only visible after delivering two coffees. (see the section "adjusting the coffee mill" on page 11)
Coffee does not come out of one of the spouts	The spouts are blocked.	Clean the spouts with a toothpick (fig. 26B)
The milk does not come out of the milk spout	The milk container lid is dirty.	Clean the milk container lid as described in the section "Cleaning the milk container"
The milk contains large bubbles and squirts out of the milk spout or there is little froth	The milk container lid is dirty	Clean the milk container lid as described in the section "cleaning the milk container"
	The milk is not cold enough or is not semi-skimmed	Use skimmed or semi-skimmed milk at refrigerator temperature (about 5°C). If the result is not as you wished, try changing brand of milk
	The froth adjustment dial is incorrectly adjusted.	Adjust following the instructions in the section "making drinks with milk"
	The milk container lid or froth adjustment dial is dirty	Clean the milk container lid and dial as described in the section "cleaning the milk container"
The appliance does not come on	It is not plugged into the mains socket	Plug into the mains socket
	The main switch (A7) is not turned on	Push the main switch (fig. 3)
The infuser cannot be extracted	The appliance has not been turned off correctly	Turn the appliance off by pressing the  button (pag. 10)

LIMITED WARRANTY

This warranty applies to all products with De'Longhi or Kenwood brand names.

What does the warranty cover?

We warrant each appliance to be free from defects in material and workmanship. Our obligation under this warranty is limited to repair at our factory or authorized service center of any defective parts or part thereof, other than parts damaged in transit. In the event of a products replacement or return, the unit must be returned transportation prepaid. The repaired or replacement model will be returned at the company expense.

This warranty shall apply only if the appliance is used in accordance with the factory directions, which accompany it, and on an Alternating current (AC) circuit.

How long does the coverage last?

This warranty runs for two years (2) from the purchase date found on your receipt and applies only to the original purchaser for use.

What is not covered by the warranty?

The warranty does not cover defects or damage of the appliance, which result from repairs or alterations to the appliance outside our factory or authorized service centers, nor shall it apply to any appliance, which has been subject to abuse, misuse, negligence or accidents. Also, consequential and incidental damage resulting from the use of this product or arising out of any breach of contract or breach of this warranty are not recoverable under this warranty. Some states do not allow the exclusion or limitation of incidental or consequential damage, so the above limitation may not apply to you.

How do you get service?

If repairs become necessary, see contact information below:

U.S. Residents: Please contact our toll free hotline at 1-866-528-8323 (1-866-Latte-Best) or log onto our website at www.delonghi.com

Residents of Canada: Please contact our toll free hotline at 1-888-335-6644 or log onto our website at www.delonghi.com

Residents of Mexico: Please contact our toll free number 01-800-711-8805 for assistance or log onto our website at www.delonghi.com

The above warranty is in lieu of all other express warranties and representations. All implied warranties are limited to the applicable warranty period set forth above. This limitation does not apply if you enter into an extended warranty with De'Longhi. Some states/countries do not allow limitations on how long an implied warranty lasts, so the above exclusions may not apply to you. De'Longhi does not authorize any other person or company to assume for it any liability in connection with the sale or use of its appliance.

How does country law apply?

This warranty gives you specific legal rights, and you may also have other rights, which vary from state to state/country to country.